

**PARTS
CATALOGUE
CATALOGO
DE REPUESTOS**

F300GET'23 (6KF3)

FL300GET'23 (6KG3)



1X6KF-200SA

()

F300GET/FL300GET
PARTS CATALOGUE
©2023 by Yamaha Motor Co., Ltd.
1st edition, July 2023
All rights reserved.
Any reprinting or unauthorized use
without the written permission of
Yamaha Motor Co., Ltd.
is expressly prohibited.
Printed in Japan.

F300GET/FL300GET
CATALOGO DE REPUESTOS
©2023 por Yamaha Motor Co., Ltd.
1ª edición, julio 2023
Todos los derechos reservados.
Toda reproducción o uso no autorizado
sin el consentimiento escrito de
Yamaha Motor Co., Ltd.
quedan expresamente prohibidos
Impreso en Japón.

FOREWORD

This Parts Catalogue is related to the parts for the model(s) on the cover page. When you are ordering replacement parts, please refer to this Parts Catalogue and quote both part numbers and part names correctly.

1. Modifications or additions which have been made after the issue of the Parts Catalogue will be announced in the Parts News.
It is advisable that you make the necessary corrections to the Parts Catalogue according to the Parts News.

2. Abbreviations

The following abbreviations are used in this Parts Catalogue.

“UR” Use specified parts number.

“UN” Use as many as needed.

“AP” Alternate Parts

“LM” Locally Made (Parts need to be ordered locally)

“F#” Frame No. (Applicable machine No.)

“O/S” Over Size

3. The number of components for assembly

- Parts, which are to be supplied in an assembly, are listed with a dot (.) in front of the part name as shown below.
- The numeral appearing to the right of each component part indicates the quantity of parts for each assembly unit.

PART NO.	DESCRIPTION	Q'TY	REMARKS
2F5-83310-60	FRONT FLASHER LIGHT ASSY	2	
115-83311-60	.BULB (6V-18W)	1	

4. Applicable colours of graphics are represented in the “REMARKS” as shown below.

PART NO.	DESCRIPTION	Q'TY	REMARKS
2N4-24110-00-X5	FUEL TANK COMP.	2	MXR
3J1-24240-10	.GRAPHIC, FUEL TANK	1	FOR MXR

5. Note that the illustrations for reference in finding parts numbers are not to be used for assembling. When assembling, please use the applicable service manual.

6. The asterisk (*) before a reference number indicates modified items after the first edition.

7. Applicable Serial No.

Engine Serial No.

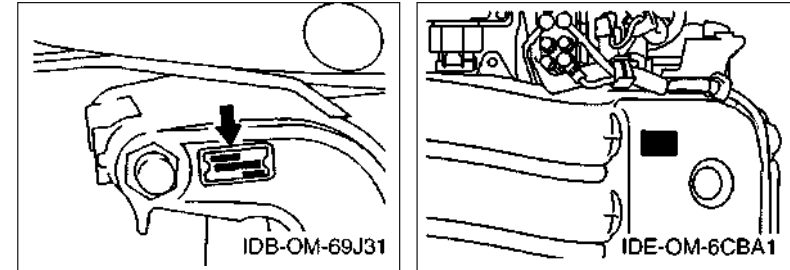

8. Applicable Engine Starting Serial No.

Model	Serial No.	Model	Serial No.
F300G	6KF-1013964	FL300G	6KG-1002393

9. Applicable Colour Code

Abbreviation	Colour Name	Colour Code
DBN1	DARK BLUISH GRAY 1	008D
WPA	WHITE PEARL A	00CE

10. Quantity Column Information

Column No.	Name Of Q'ty Column	Applicable Model
1	6KF3	F300GET/ET2
2	6KG3	FL300GET/ET2

PROLOGO

Este catálogo de repuestos corresponde a las piezas para el o los modelos que figuran en la página de portada. Al formular el pedido de repuestos, se ruega citar este catálogo y especificar correctamente el número y el nombre de las piezas.

- Las modificaciones y agregados que se hayan realizado después de la edición de este Catálogo de Repuestos, serán anunciados en las Informaciones de Recambios. Es recomendable que se hagan las correcciones necesarias en el Catálogo de Repuestos de acuerdo con las Informaciones de Recambios.

2. Abreviaciones

En este Catálogo de Repuestos se emplean las siguientes abreviaciones.

“UR” Usar el número de partes especificado

“UN” Usar la cantidad necesaria

“AP” Piezas sustitutivas

“LM” Fabricación local (Hay que pedir los repuestos en las cercanías)

“F#” N° de bastidor (N° aplicable a la máquina)

“O/S” Sobredimensionado

3. La cantidad de componentes para el montaje

- Los componentes, suministrados como conjunto, se describen con un punto (.) que precede al nombre del parte como se indica a continuación.
- La numeración que aparece a la derecha de cada descripción indica la cantidad de partes por cada unidad de conjunto.

CODIGO N°	DESCRIPCION	CANT.	OBSERVACIONES
2F5-83310-60	ENSAMBLAJE DE LA LUZ	2	
115-83311-60	.BOMBILLA (6V-18W)	1	

4. Los colores de los componentes se indican como sigue en la columna de “OBSERVACIONES”.

CODIGO N°	DESCRIPCION	CANT.	OBSERVACIONES
2N4-24110-00-X5	COMP. DEL TANQUE	2	MXR
3J1-24240-10	.GRAFICO, DEL TANQUE	1	PARA MXR

- Debe tenerse en cuenta que las ilustraciones sirven como guía para la búsqueda de los números de partes y no deben usarse para el montaje. Durante el montaje, se recomienda usar el manual de taller correspondiente.

- EL asterisco (*) antes del número de referencia indica los elementos modificados después de la primera edición.

7. Números de serie

N° de Serie del motor

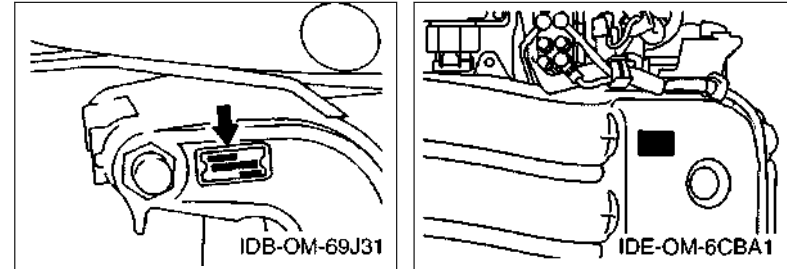

8. Números de serie del motor

Modelo	N° de serie	Modelo	N° de serie
F300G	6KF-1013964	FL300G	6KG-1002393

9. Códigos de color aplicables

Abreviatura	Nombre de color	Código de color
DBN1	DARK BLUISH GRAY 1	008D
WPA	WHITE PEARL A	00CE

10. Información para la columna de cantidades

Columna N°	Nombre de la columna de cantidades	Modelo aplicable
1	6KF3	F300GET/ET2
2	6KG3	FL300GET/ET2

CONTENTS

SCHEDULED SERVICE PARTS.....	1
TOP COWLING.....	2
CYLINDER & CRANKCASE 1.....	4
CRANKSHAFT & PISTON.....	6
CYLINDER & CRANKCASE 2.....	7
CYLINDER & CRANKCASE 3.....	9
CYLINDER & CRANKCASE 4.....	10
VALVE.....	11
INTAKE 1.....	14
INTAKE 2.....	15
THROTTLE BODY ASSY 1.....	17
THROTTLE BODY ASSY 2.....	18
FUEL INJECTION PUMP 1.....	19
FUEL INJECTION PUMP 2.....	21
FUEL 1.....	22
FUEL 2.....	23
GENERATOR.....	24
ELECTRICAL 1.....	25
ELECTRICAL 2.....	27
ELECTRICAL 3.....	28
ELECTRICAL 4.....	30
ELECTRICAL 5.....	32
STARTING MOTOR.....	33
BOTTOM COWLING 1.....	34
BOTTOM COWLING 2.....	36
BOTTOM COWLING 3.....	38
CONTROL.....	39
BRACKET 1.....	41
BRACKET 2.....	43
BRACKET 3.....	44
POWER TRIM & TILT ASSY 1.....	46
POWER TRIM & TILT ASSY 2.....	50
UPPER CASING.....	51
OIL PAN.....	53
LOWER CASING & DRIVE 1.....	54
LOWER CASING & DRIVE 2.....	59
LOWER CASING & DRIVE 3.....	61
LOWER CASING & DRIVE 4.....	65
STEERING GUIDE ATTACHMENT 1.....	67
STEERING GUIDE ATTACHMENT 2.....	68

DEC 1 (SINGLE).....	69
DEC 2 (SINGLE).....	70
DEC 3 (TWIN).....	71
DEC 4 (TWIN).....	72
OPTIONAL PARTS 1.....	73
OPTIONAL PARTS 2.....	74
OPTIONAL PARTS 3.....	75
OPTIONAL PARTS 4.....	76
OPTIONAL PARTS 5.....	77
OPTIONAL PARTS 6.....	78
OPTIONAL PARTS 7.....	79
REPAIR KIT 1.....	80
REPAIR KIT 2.....	81

INDEX

NUMERICAL INDEX.....	83
----------------------	----

CONTENIDO

PARTES DE REPUESTO TEMPORALES.....	1
SOPORTE SUPERIOR.....	2
CILINDRO & CARTER 1.....	4
CIGUENAL & PISTON.....	6
CILINDRO & CARTER 2.....	7
CILINDRO & CARTER 3.....	9
CILINDRO & CARTER 4.....	10
VALVULA.....	11
ADMISION 1.....	14
ADMISION 2.....	15
CAJA DE ACELERADOR COMPL 1.....	17
CAJA DE ACELERADOR COMPL 2.....	18
BOMBA DE INYECTOR 1.....	19
BOMBA DE INYECTOR 2.....	21
COMBUSTIBLE 1.....	22
COMBUSTIBLE 2.....	23
GENERADOR.....	24
EQUIPO ELECTRICO 1.....	25
EQUIPO ELECTRICO 2.....	27
EQUIPO ELECTRICO 3.....	28
EQUIPO ELECTRICO 4.....	30
EQUIPO ELECTRICO 5.....	32
MOTOR DE ARRANQUE.....	33
CUBIERTA INFERIOR 1.....	34
CUBIERTA INFERIOR 2.....	36
CUBIERTA INFERIOR 3.....	38
CONTROL.....	39
SOPORTE 1.....	41
SOPORTE 2.....	43
SOPORTE 3.....	44
COMPONER Y PODER VARILLA 1.....	46
COMPONER Y PODER VARILLA 2.....	50
FUNDA SUPERIOR.....	51
OIL PAN.....	53
IMPULSOR E INFERIOR 1.....	54
IMPULSOR E INFERIOR 2.....	59
IMPULSOR E INFERIOR 3.....	61
IMPULSOR E INFERIOR 4.....	65
ADITAMENTO GUIA DE GOBIERNO 1.....	67
ADITAMENTO GUIA DE GOBIERNO 2.....	68

DEC 1 (UNICO).....	69
DEC 2 (UNICO).....	70
DEC 3 (DOBLE).....	71
DEC 4 (DOBLE).....	72
PARTES OPCIONALES 1.....	73
PARTES OPCIONALES 2.....	74
PARTES OPCIONALES 3.....	75
PARTES OPCIONALES 4.....	76
PARTES OPCIONLES 5.....	77
PARTES OPCIONALES 6.....	78
PARTES OPCIONALES 7.....	79
ESTUCHE REPARATION 1.....	80
ESTUCHE REPARATION 2.....	81

INDICE

INDICE NUMERICO.....	83
----------------------	----

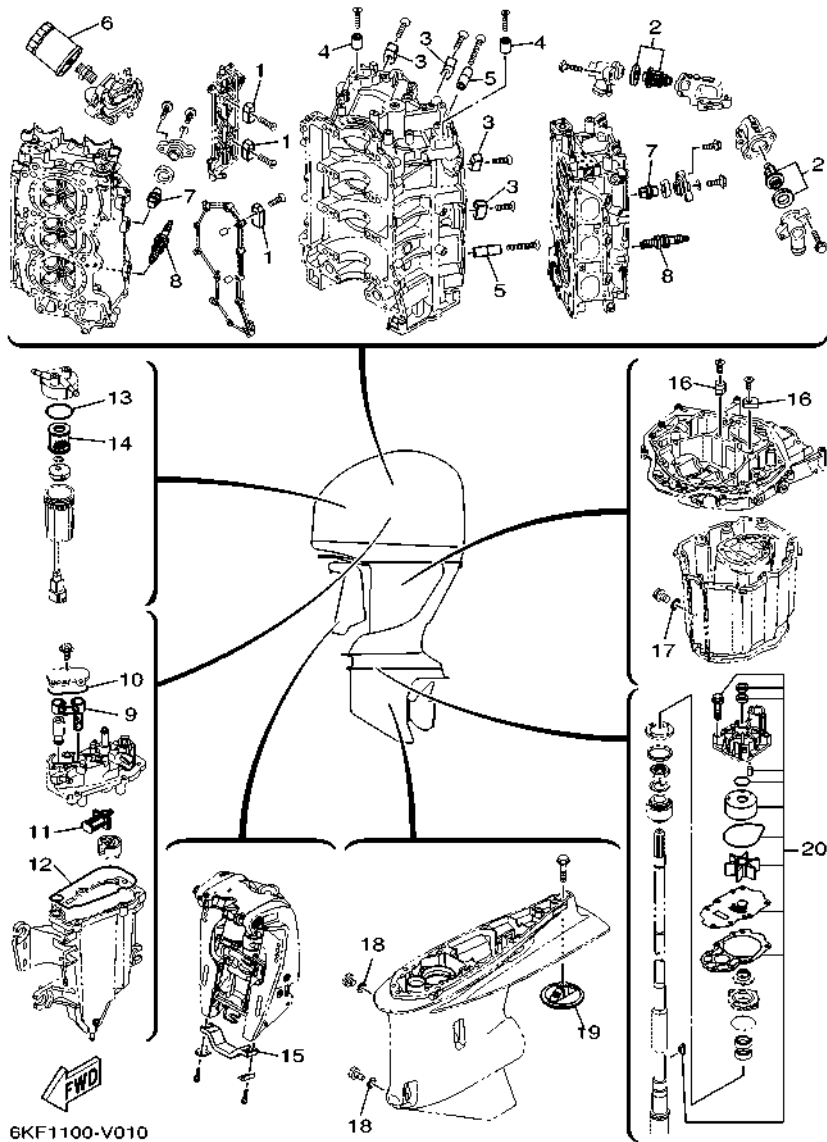

FIG. 1 SCHEDULED SERVICE PARTS

PARTES DE REPUESTO TEMPORALES

REF. NO.	PART NO. CODIGO N°	DESCRIPTION DESCRIPCION	6KF3	6KG3	REMARKS OBSERVACIONES
1	63P-11325-01	ANODE ANODO	4	4	
2	6CE-12411-00	THERMOSTAT TERMOSTAT	2	2	
3	6AW-1132P-00	ANODE 5 ANODO 5	4	4	
4	68T-11325-00	ANODE ANODO	2	2	
5	6AW-1132N-01	ANODE 4 ANODO 4	2	2	
6	N26-13440-03	ELEMENT ASSY, OIL CLEANER ELEMENTO FILTRO DE ACEITE	1	1	
7	67F-11325-01	ANODE ANODO	8	8	
8	94702-00400	PLUG, SPARK (NGK LFR6A-11) BUJIA (NGK LFR6A-11)	6	6	
9	6CB-24501-01	FILTER, FUEL FIELTRO	1	1	
10	6CB-13016-00	O-RING ANILLO O	1	1	
11	63P-13915-00	FILTER FILTRO	1	1	
12	6CB-14984-00	GASKET, FLOAT CHAMBER EMPAQUE CAMARA DE BOIA	1	1	
13	6P3-24564-00	GASKET EMPAQUE	1	1	
14	6P3-24563-02	ELEMENT, FILTER ELEMENTO DEL FILTRO	1	1	
15	6G5-45251-02	ANODE CATODE	1	1	
16	63P-11325-11	ANODE ANODO	2	2	
17	90430-14M09	GASKET JUNTA	1	1	
18	90430-08003	GASKET JUNTA	2	2	
19	6CE-45373-00	ANODE ANODO	1	1	
20	6CE-W0078-02	WATER PUMP REPAIR KIT ESTUCHE REPARACION BOMBA AGUA	1	1	

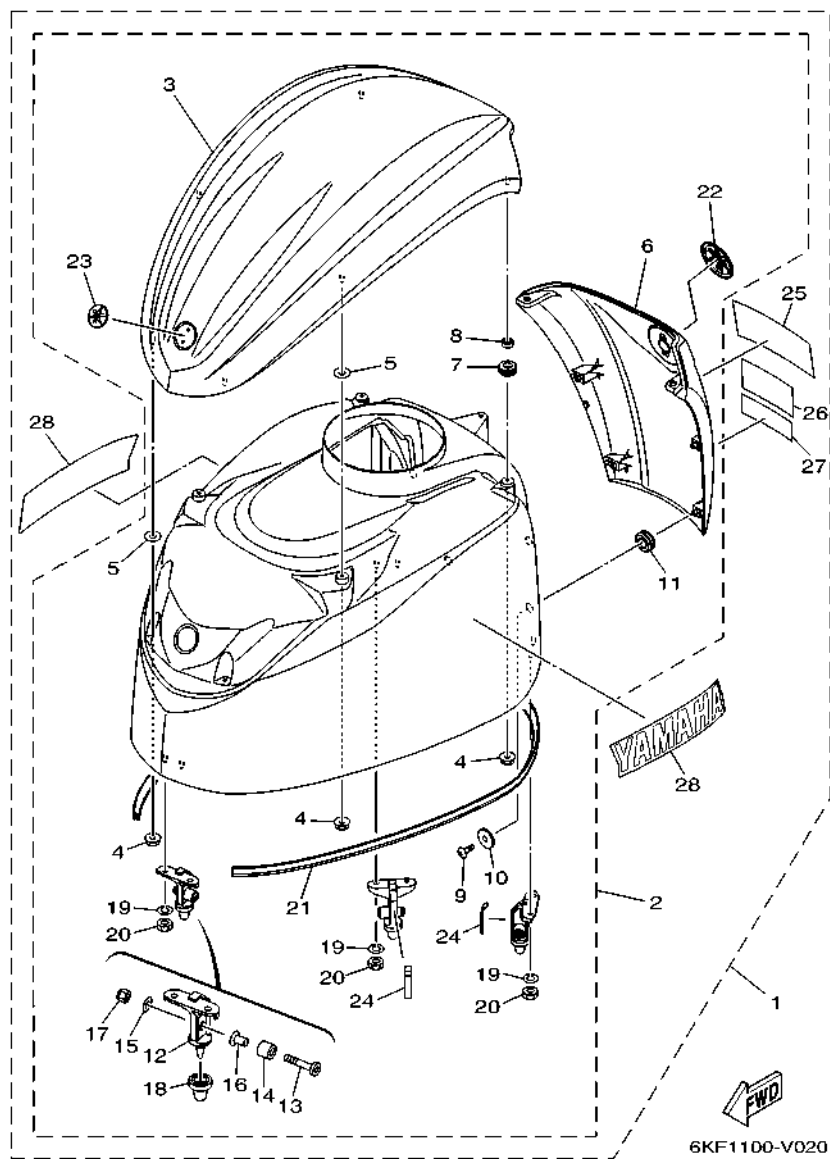

FIG. 2 TOP COWLING

SOPORTE SUPERIOR

REF. NO.	PART NO. CODIGO N°	DESCRIPTION DESCRIPCION	6KF3	6KG3	REMARKS OBSERVACIONES
1	6KF-42610-00-8D	TOP COWLING ASSY SOPORTE SUPERIOR COMPL.	1	1	UR GRAY
	6KF-42610-10-CE	TOP COWLING ASSY SOPORTE SUPERIOR COMPL.	1	1	UR GRAY UR WHITE
2	6KA-4261A-00-8D	.TOP COWLING W/O GRAPHICS .SOPORTE SUPERIOR SIN GRAFICOS	1	1	UR GRAY
	6KA-4261A-00-CE	.TOP COWLING W/O GRAPHICS .SOPORTE SUPERIOR SIN GRAFICOS	1	1	UR GRAY UR WHITE
3	6KA-42613-00-8D	..MOLDING, AIR DUCT ..MOLDURA CONDUCTO AIRE	1	1	UR GRAY UR GRAY
	6KA-42613-00-CE	..MOLDING, AIR DUCT ..MOLDURA CONDUCTO AIRE	1	1	UR WHITE UR WHITE
4	90179-06M28	..NUT ..TUERCA	7	7	
5	6CB-42545-00	..WASHER, PLAIN ..ARANDELA, PLANA	4	4	
6	6KA-42625-00-8D	..PANEL, REAR ..TABLERO	1	1	UR GRAY
	6KA-42625-00-CE	..PANEL, REAR ..TABLERO	1	1	UR GRAY UR WHITE UR WHITE
7	90480-13004	..GROMMET ..TAPON	2	2	
8	90387-07054	..COLLAR ..ESPACIADOR	2	2	
9	97780-50016	..SCREW, TAPPING ..TORNILLO DE CABEZA DE CONO ACH	4	4	
10	90201-053R1	..WASHER, PLATE ..ARANDELA PLANA	4	4	
11	90480-16009	..GROMMET ..TAPON	4	4	
12	6CB-42647-A0	..HOLDER, CLAMP BAND ..MORDAZA DE ABRAZADERA	3	3	
13	90111-08078	..BOLT, HEXAGON SOCKET BUTTON ..TORNILLO	3	3	
14	90387-10094	..COLLAR ..ESPACIADOR	3	3	
15	92990-08600	..WASHER, PLATE ..ARANDELA PLANA	3	3	
16	90387-08M45	..COLLAR ..ESPACIADOR	3	3	
17	95780-08300	..NUT, FLANGE ..TUERCA	3	3	
18	6AW-42663-01	..DAMPER 2 ..AMORTIGUADOR 2	3	3	
19	92990-06100	..WASHER, SPRING ..ARANDELA PLANA	6	6	
20	95380-06600	..NUT, HEXAGON ..TUERCA	6	6	
21	6CB-42628-00	..SEAL ..SELLO DE GOMA	1	1	
22	6AW-42697-10	..TUNING FORK MARK ..MARCA, YAMAHA	1	1	
23	F2S-6411H-00	..EMBLEM, TUNING FORK ..EMBLEMA, DIAPASON	1	1	

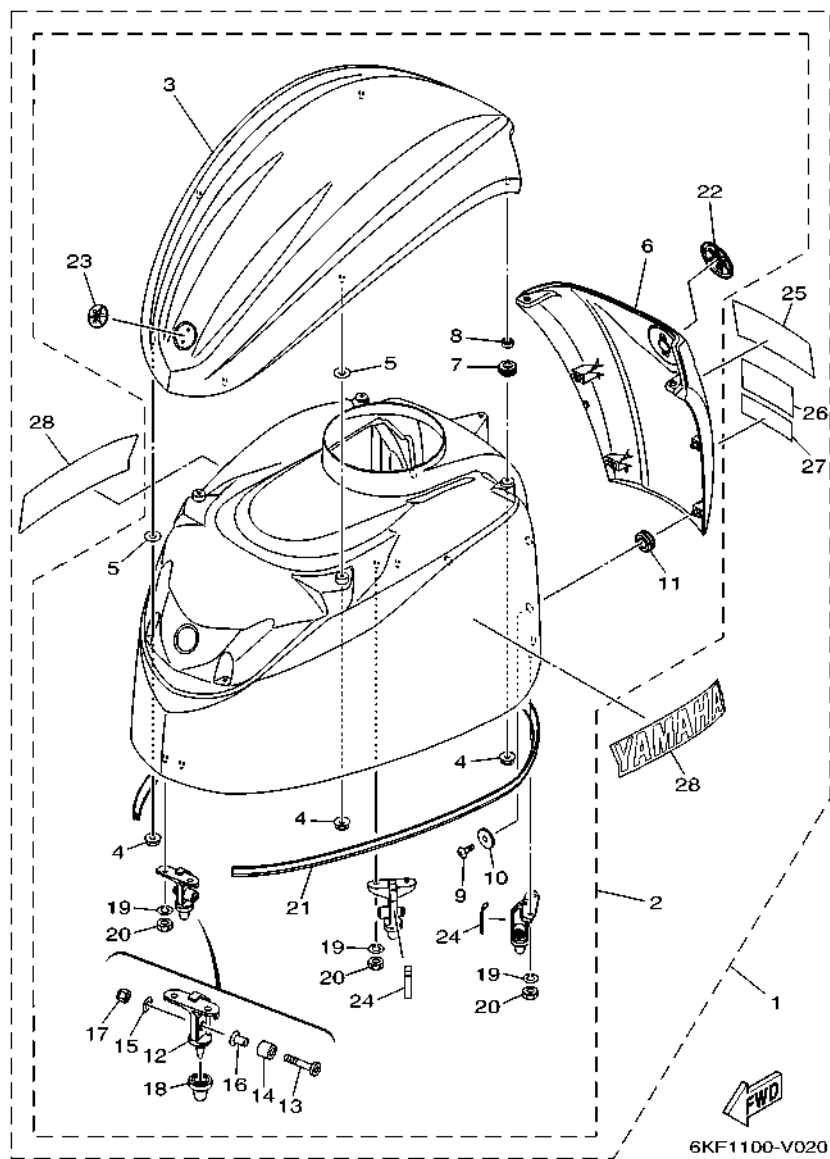

FIG. 2 TOP COWLING

SOPORTE SUPERIOR

REF. NO.	PART NO. CODIGO N°	DESCRIPTION DESCRIPCION	6KF3	6KG3	REMARKS OBSERVACIONES
24	6CB-42134-01	.COVER .CUBIERTA	2	2	
25	6KF-42678-00	.GRAPHIC, REAR .CALCAMONIA TRASERA	1	1	
26	6KF-4267A-00	.GRAPHIC, REAR 2 .CALCAMONIA TRASERA 2	1	1	
27	6KF-42682-00	.MARK, COWLING .MARCA DE CUBIERTA	1	1	
28	6KF-2153A-00	.EMBLEM, YAMAHA .EMBLEMA, YAMAHA	2	2	FOR GRAY COWL. FOR GRAY COWL.
	6KF-2153A-10	.EMBLEM, YAMAHA .EMBLEMA, YAMAHA	2	2	FOR WHITE COWL. FOR WHITE COWL.

- 1
- LONG BLOCK ASSY**
- Fig. 3, CYLINDER & CRANKCASE 1
Ref. No. 2 to 45
- Fig. 4, CRANKSHAFT & PISTON
Ref. No. 1 to 15
- Fig. 5, CYLINDER & CRANKCASE 2
Ref. No. 2 to 10, 12 to 46
- Fig. 6, CYLINDER & CRANKCASE 3
Ref. No. 1 to 11
- Fig. 7, CYLINDER & CRANKCASE 4
Ref. No. 1 to 16
- Fig. 8, VALVE
Ref. No. 1 to 32
- Fig. 9, INTAKE 1
Ref. No. 6, 7
- Fig. 10, INTAKE 2
Ref. No. 7 to 9, 14, 35
- Fig. 12, THROTTLE BODY ASSY 2
Ref. No. 1 to 9
- Fig. 17, GENERATOR
Ref. No. 2
- Fig. 18, ELECTRICAL 1
Ref. No. 17, 21 to 34
- Fig. 19, ELECTRICAL 2
Ref. No. 5, 6, 8
- Fig. 21, ELECTRICAL 4
Ref. No. 21 to 24
- Fig. 25, BOTTOM COWLING 2
Ref. No. 8 to 14, 21 to 24
- Fig. 33, UPPER CASING
Ref. No. 14, 16, 17, 19, 23,
24, 26
- Fig. 34, OIL PAN
Ref. No. 5 to 7, 9 to 17, 20

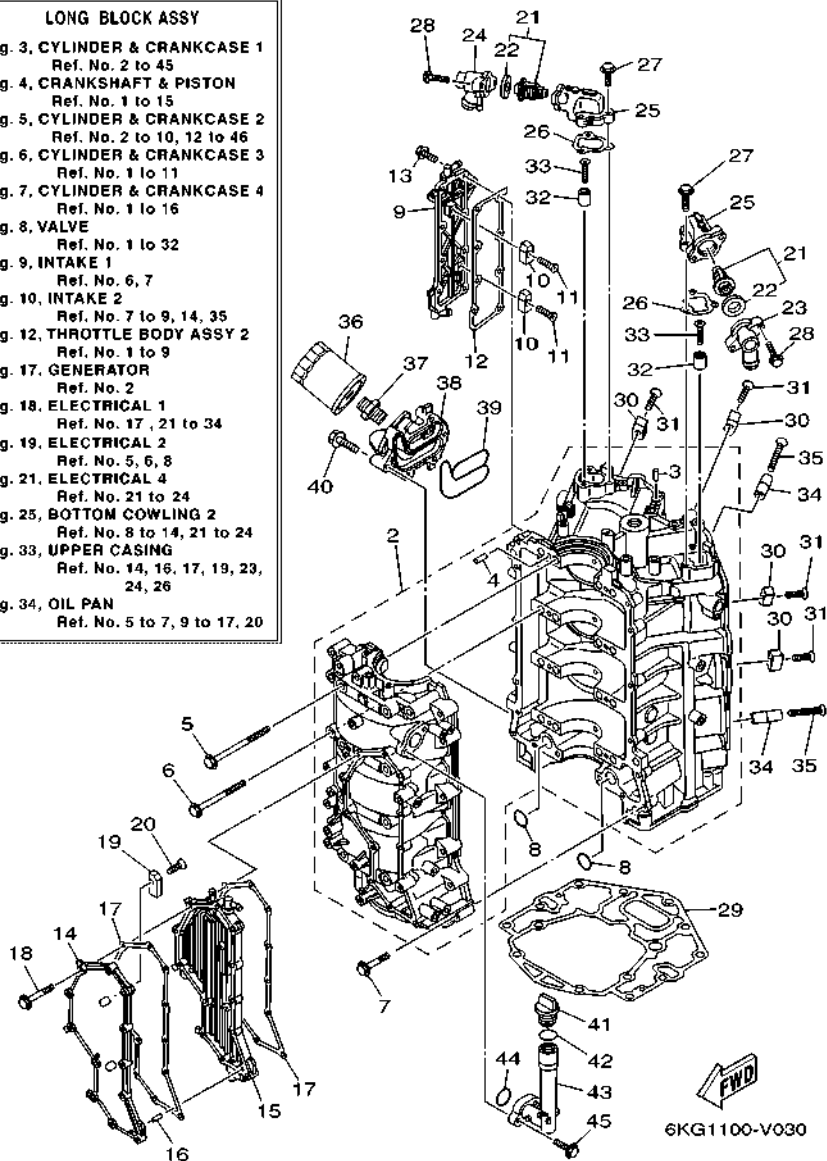

FIG. 3 CYLINDER & CRANKCASE 1

CILINDRO & CARTER 1

REF. NO.	PART NO. CODIGO N°	DESCRIPTION DESCRIPCION	6KFS	6KGS		REMARKS OBSERVACIONES
1	6KA-11000-00	LONG BLOCK ASSY SUBENSAMBLAJE DEL MOTOR	1	1		
2	6CE-15100-10	CRANKCASE ASSY CARTER COMPLETO	1	1		
3	93606-12019	.PIN, DOWEL .PASADOR DE CLAVIJA	3	3		
4	93606-12019	.PIN, DOWEL .PASADOR DE CLAVIJA	8	8		
5	6CB-15187-00	BOLT PERNO	8	8		
6	6CB-15481-00	BOLT 1 PERNO 1	8	8		
7	90105-08175	BOLT, FLANGE TORNILLO	16	16		
8	93210-26658	O-RING ANILLO O	2	2		
9	6CE-1131C-00-9S	COVER, JOINT CUBIERTA DE UNION	1	1		
10	63P-11325-01	ANODE ANODO	2	2		
11	90151-06M02	SCREW, COUNTERSUNK TORNILLO EMBUTIDO	2	2		
12	6CB-1131B-00	GASKET, COVER EMPAQUE DE CUBIERTA	1	1		
13	90105-06M07	BOLT, FLANGE TORNILLO	8	8		
14	6CE-15411-00-9S	COVER, CRANKCASE 1 CUBIERTA DE CARTER 1	1	1		
15	6CE-15421-10-9S	COVER, CRANKCASE 2 TAPA DE CARTER DERECHA	1	1		
16	91690-40010	PIN, SPRING PASADOR DE RESORTE	1	1		
17	6CB-15451-01	GASKET, CRANKCASE COVER 1 EMPAQ DE CUBIERTA DE CARTER	2	2		
18	90105-06151	BOLT, FLANGE TORNILLO	12	12		
19	63P-11325-01	ANODE ANODO	2	2		
20	90151-06M02	SCREW, COUNTERSUNK TORNILLO EMBUTIDO	2	2		
21	6CE-12411-00	THERMOSTAT TERMOSTAT	2	2		
22	67F-12412-00	.SEAL, THERMOSTAT .SELLO TERMOSTATO	1	1		
23	6CE-12413-B0-9S	COVER, THERMOSTAT CUBIERTA TERMOSTATO	1	1		
24	6CE-12413-A0-9S	COVER, THERMOSTAT CUBIERTA TERMOSTATO	1	1		
25	6CB-12422-10-9S	COVER, HOUSING CUBIERTA DE CAJA	2	2		
26	6CB-12427-11	GASKET, HOUSING COVER 1 EMPAQUE DE TAPA	2	2		
27	95027-06025	BOLT, FLANGE PERNO, DE BRIDA	6	6		

- 1
- LONG BLOCK ASSY**
- Fig. 3, CYLINDER & CRANKCASE 1
Ref. No. 2 to 45
 - Fig. 4, CRANKSHAFT & PISTON
Ref. No. 1 to 15
 - Fig. 5, CYLINDER & CRANKCASE 2
Ref. No. 2 to 10, 12 to 46
 - Fig. 6, CYLINDER & CRANKCASE 3
Ref. No. 1 to 11
 - Fig. 7, CYLINDER & CRANKCASE 4
Ref. No. 1 to 16
 - Fig. 8, VALVE
Ref. No. 1 to 32
 - Fig. 9, INTAKE 1
Ref. No. 6, 7
 - Fig. 10, INTAKE 2
Ref. No. 7 to 9, 14, 35
 - Fig. 12, THROTTLE BODY ASSY 2
Ref. No. 1 to 9
 - Fig. 17, GENERATOR
Ref. No. 2
 - Fig. 18, ELECTRICAL 1
Ref. No. 17, 21 to 34
 - Fig. 19, ELECTRICAL 2
Ref. No. 5, 6, 8
 - Fig. 21, ELECTRICAL 4
Ref. No. 21 to 24
 - Fig. 25, BOTTOM COWLING 2
Ref. No. 8 to 14, 21 to 24
 - Fig. 33, UPPER CASING
Ref. No. 14, 16, 17, 19, 23,
24, 26
 - Fig. 34, OIL PAN
Ref. No. 5 to 7, 9 to 17, 20

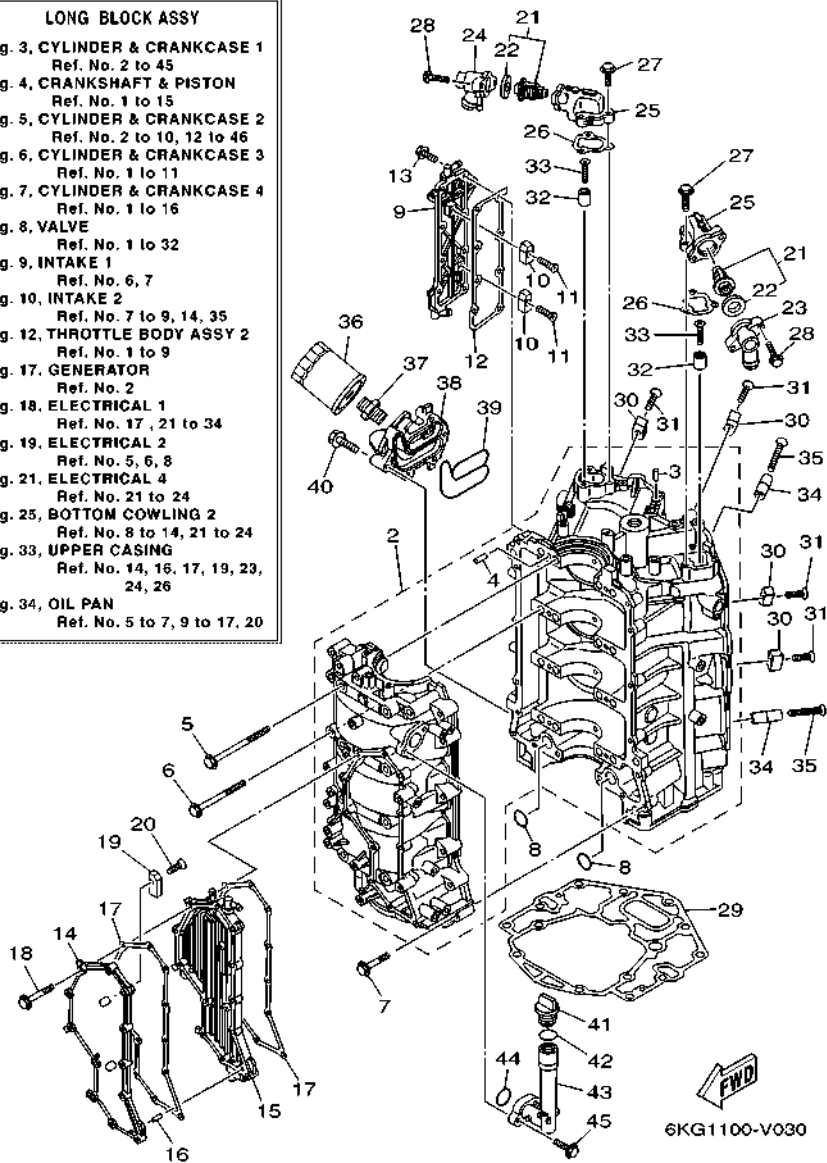

FIG. 3 CYLINDER & CRANKCASE 1

CILINDRO & CARTER 1

REF. NO.	PART NO. CODIGO N°	DESCRIPTION DESCRIPCION	6KFS	6KGS	REMARKS OBSERVACIONES
28	90105-06037	BOLT, FLANGE TORNILLO	4	4	
29	6KA-11351-00	GASKET, CYLINDER JUNTA, DE CILINDRO	1	1	
30	6AW-1132P-00	ANODE 5 ANODO 5	4	4	
31	98780-06530	SCREW, FLAT HEAD TORNILLO, CABEZA PLANA	4	4	
32	68T-11325-00	ANODE ANODO	2	2	
33	90151-05M05	SCREW, COUNTERSUNK TORNILLO EMBUTIDO	2	2	
34	6AW-1132N-01	ANODE 4 ANODO 4	2	2	
35	98780-06550	SCREW, FLAT HEAD TORNILLO, CABEZA PLANA	2	2	
36	N26-13440-03	ELEMENT ASSY, OIL CLEANER ELEMENTO FILTRO DE ACEITE	1	1	
37	90401-19001	BOLT, UNION PERNO DE UNION	1	1	
38	6CE-13446-10-9S	CONNECTOR CONECTOR	1	1	
39	6CB-13477-00	GASKET EMPAQUE	1	1	
40	90105-06151	BOLT, FLANGE TORNILLO	5	5	
41	6G8-15363-00	PLUG, OIL TAPON DE ACEITE	1	1	
42	93210-24M79	O-RING ANILLO O	1	1	
43	6CB-15319-00	JOINT CONECTOR	1	1	
44	93210-27370	O-RING ANILLO O	1	1	
45	90105-06037	BOLT, FLANGE TORNILLO	2	2	

FIG. 4 CRANKSHAFT & PISTON

CIGUENAL & PISTON

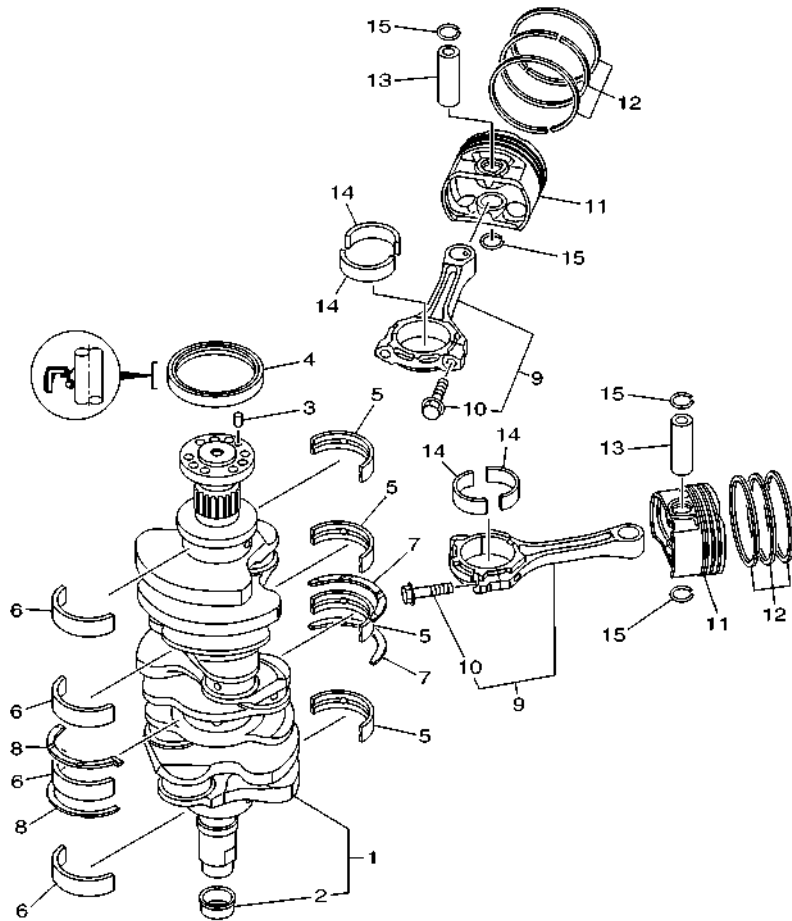

6CB3110-L030

REF. NO.	PART NO. CODIGO N°	DESCRIPTION DESCRIPCION	6KFS	6KG3			REMARKS OBSERVACIONES
1	6CB-11410-00	CRANKSHAFT CIGUENAL	1	1			
2	6CB-11478-00	.COLLAR .COLLAR	1	1			
3	93606-12019	PIN, DOWEL PASADOR DE CLAVIJA	1	1			
4	93102-85008	OIL SEAL SELLO ACEITE	1	1			
5	6CB-11416-00	PLANE BEARING, CRANKSHAFT 1 COJINETE PLANO 1	4	4			UR PURPLE UR PURPLE
6	6CB-11416-10	PLANE BEARING, CRANKSHAFT 1 COJINETE PLANO 1	4	4			UR YELLOW UR YELLOW
6	6CB-11416-20	PLANE BEARING, CRANKSHAFT 1 COJINETE PLANO 1	4	4			UR RED UR RED
6	6CB-11416-30	PLANE BEARING, CRANKSHAFT 1 COJINETE PLANO 1	4	4			UR GREEN UR GREEN
6	6CB-11416-40	PLANE BEARING, CRANKSHAFT 1 COJINETE PLANO 1	4	4			UR BROWN UR BROWN
6	6CB-11417-00	PLANE BEARING, CRANKSHAFT 2 COJINETE PLANO 2	4	4			UR PURPLE UR PURPLE
6	6CB-11417-10	PLANE BEARING, CRANKSHAFT 2 COJINETE PLANO 2	4	4			UR YELLOW UR YELLOW
6	6CB-11417-20	PLANE BEARING, CRANKSHAFT 2 COJINETE PLANO 2	4	4			UR RED UR RED
6	6CB-11417-30	PLANE BEARING, CRANKSHAFT 2 COJINETE PLANO 2	4	4			UR GREEN UR GREEN
6	6CB-11417-40	PLANE BEARING, CRANKSHAFT 2 COJINETE PLANO 2	4	4			UR BROWN UR BROWN
7	6CB-11426-03	BEARING, THRUST 1 COJINETE DE EMPUJE 1	2	2			
8	6CB-11427-03	BEARING, THRUST 2 COJINETE DE EMPUJE 2	2	2			
9	6CB-W1165-10	CONNECTING ROD ASSY BIELA COMPLETA	6	6			
10	63P-11654-10	.BOLT, CONNECTING ROD .TORNILLO DE BIELA	2	2			
11	6CE-11631-02	PISTON (STD) PISTON (NORMA)	6	6			
12	6CB-11603-00	PISTON RING SET (STD) JUEGO DE ANILLOS (NORMA)	6	6			
13	6CB-11633-00	PIN, PISTON PASADOR, PISTON	6	6			
14	6JD-11656-00	PLANE BEARING, CONNECTING ROD COJINETE PLANO	12	12			UR BLACK UR BLACK
6	6JD-11656-10	PLANE BEARING, CONNECTING ROD COJINETE PLANO	12	12			UR PINK UR PINK
6	6JD-11656-20	PLANE BEARING, CONNECTING ROD COJINETE PLANO	12	12			UR RED UR RED
15	K0F-A3233-00	RING,HOLE SNAP PRESILLA	12	12			

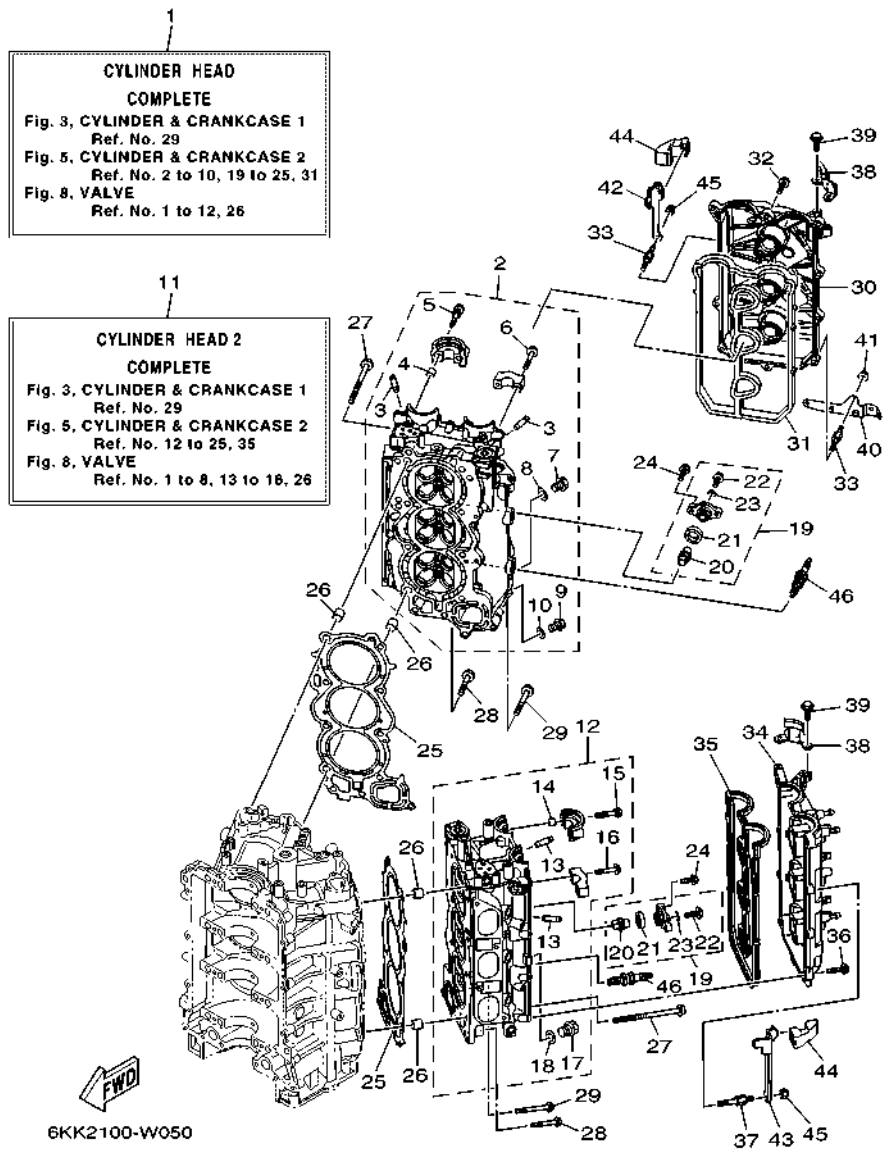

FIG. 5 CYLINDER & CRANKCASE 2

CILINDRO & CARTER 2

REF. NO.	PART NO. CODIGO N°	DESCRIPTION DESCRIPCION	6KFS	6KGS	REMARKS OBSERVACIONES
1	6KA-W009A-00-9S	CYLINDER HEAD COMPLETE CILINDRO CULATA COMPLETO	1	1	
2	6CE-11110-12-9S	CYLINDER HEAD ASSY CULATA DE CILINDRO COMPLETA	1	1	
3	6S5-11133-10	.GUIDE, VALVE 1 .GUIA DE VALVULA 1	12	12	
4	91809-08006	.PIN, DOWEL .PASADOR DE CLAVIJA	4	4	
5	90119-07001	.BOLT, WITH WASHER .TORNILLO CON ARANDELA	4	4	
6	90119-07234	.BOLT, WITH WASHER .TORNILLO CON ARANDELA	12	12	
7	90340-18M09	.PLUG, STRAIGHT SCREW .TORNILLO, DE DRENAJE	1	1	
8	90201-186F1	.WASHER, PLATE .ARANDELA PLANA	1	1	
9	90340-14M06	.PLUG, STRAIGHT SCREW .TORNILLO, DE DRENAJE	1	1	
10	90430-14115	.GASKET .JUNTA	1	1	
11	6KA-W009C-00-9S	CYLINDER HEAD 2 COMPLETE CULATA DE CILINDRO COMPL. 2	1	1	
12	6CE-11120-12-9S	CYLINDER HEAD ASSY 2 CULATA DE CILINDRO COMPL. 2	1	1	
13	6S5-11133-10	.GUIDE, VALVE 1 .GUIA DE VALVULA 1	12	12	
14	91809-08006	.PIN, DOWEL .PASADOR DE CLAVIJA	4	4	
15	90119-07001	.BOLT, WITH WASHER .TORNILLO CON ARANDELA	4	4	
16	90119-07234	.BOLT, WITH WASHER .TORNILLO CON ARANDELA	12	12	
17	90340-18M09	.PLUG, STRAIGHT SCREW .TORNILLO, DE DRENAJE	1	1	
18	90201-186F1	.WASHER, PLATE .ARANDELA PLANA	1	1	
19	67F-11301-01	ANODE COVER ASSY CONJUNTO CUBIERTA DE ANODO	8	8	
20	67F-11325-01	.ANODE .ANODO	1	1	
21	67F-11328-01	.GROMMET, ANODE .TAPON	1	1	
22	90105-06M07	.BOLT, FLANGE .TORNILLO	1	1	
23	90430-06M03	.GASKET .JUNTA	1	1	
24	95D95-08025	BOLT, FLANGE DEEP RECESS CERROJO, REBORDE HUECO PROFUND	16	16	
25	6CB-11181-00	GASKET, CYLINDER HEAD 1 JUNTA, DE CULATA 1	2	2	
26	90387-11005	COLLAR ESPACIADOR	4	4	
27	90149-11001	SCREW TORNILLO DE REGLAJE	16	16	

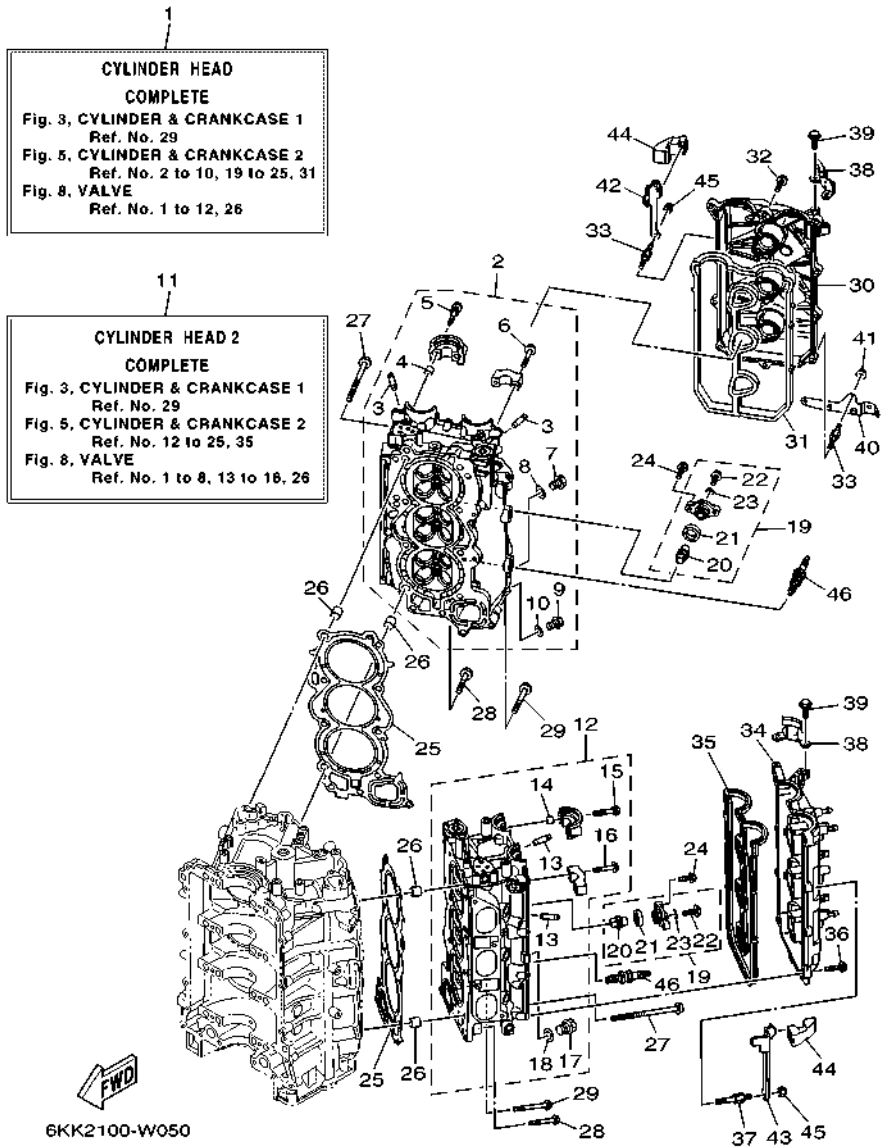

FIG. 5 CYLINDER & CRANKCASE 2

CILINDRO & CARTER 2

REF. NO.	PART NO. CODIGO N°	DESCRIPTION DESCRIPCION	6KFS	6KGS	REMARKS OBSERVACIONES
28	90105-08175	BOLT, FLANGE TORNILLO	4	4	
29	90105-08220	BOLT, FLANGE TORNILLO	2	2	
30	6CB-11191-02	COVER, CYLINDER HEAD 1 TAPA CULATA DE CILINDRO 1	1	1	
31	6CB-11193-00	GASKET, HEAD COVER 1 EMPAQUE	1	1	
32	95D95-06030	BOLT, FLANGE DEEP RECESS CERROJO, REBORDE HUECO PROFUND	9	9	
33	90109-06277	BOLT PERNO	4	4	
34	6CB-11192-02	COVER, CYLINDER HEAD 2 TAPA CULATA DE CILINDRO 2	1	1	
35	6CB-11194-00	GASKET, HEAD COVER 2 EMPAQUE DE TAPA DE CULATA 2	1	1	
36	95D95-06030	BOLT, FLANGE DEEP RECESS CERROJO, REBORDE HUECO PROFUND	11	11	
37	90109-06277	BOLT PERNO	2	2	
38	6AW-15142-00	GUIDE 1 GUIA 1.	2	2	
39	95D95-06014	BOLT, FLANGE DEEP RECESS CERROJO, REBORDE HUECO PROFUND	4	4	
40	6KA-2134V-00	BRACKET SOPORTE	1	1	
41	90179-06M28	NUT TUERCA	2	2	
42	6KW-11998-00	BRACKET 1 SOPORTE 1	1	1	
43	6KW-11999-00	BRACKET 2 SOPORTE 2	1	1	
44	6KW-42662-00	DAMPER AMORTIGUADOR	2	2	
45	90185-06M07	NUT, SELF-LOCKING TUERCA AUTOBLOCANTE	4	4	
46	94702-00400	PLUG, SPARK (NGK LFR6A-11) BUJIA (NGK LFR6A-11)	6	6	

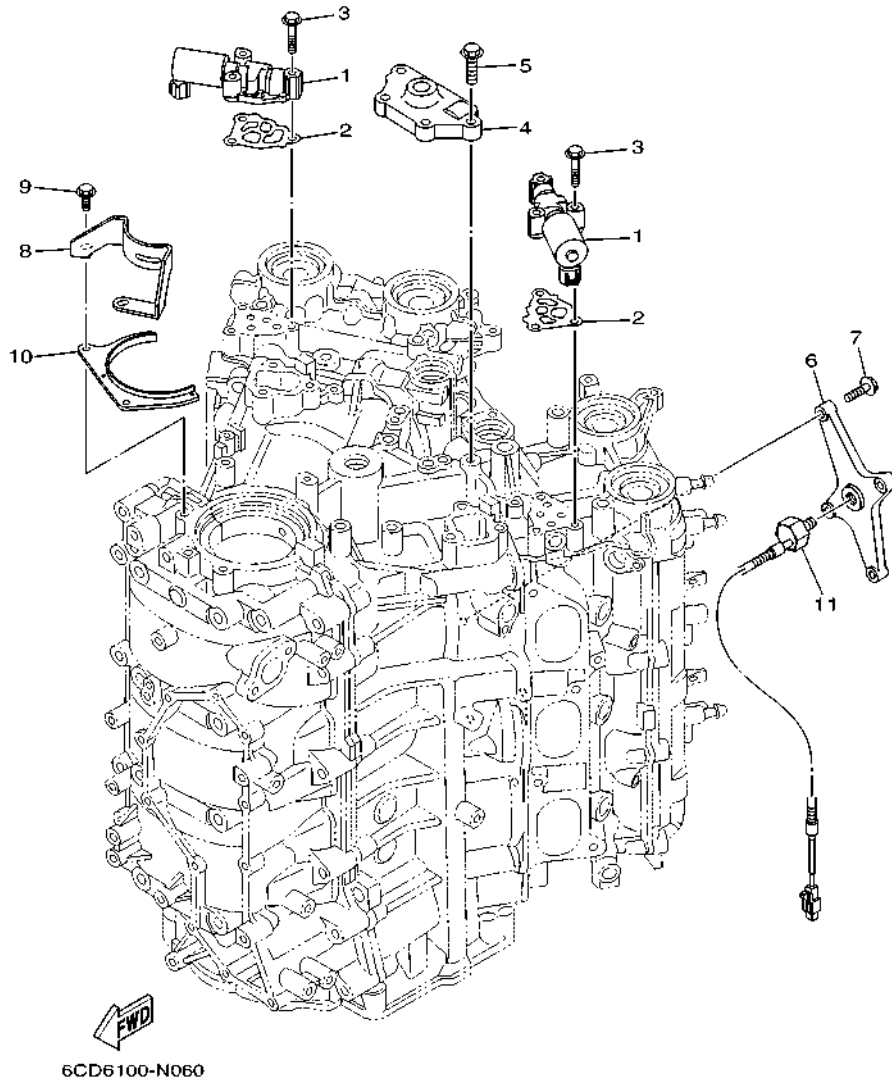

FIG. 6 CYLINDER & CRANKCASE 3

CILINDRO & CARTER 3

REF. NO.	PART NO. CODIGO N°	DESCRIPTION DESCRIPCION	6KFS	6KG3	REMARKS OBSERVACIONES
1	6CB-86120-00	SOLENOID VALVE ASSY VALVULA SOLENOIDE CONJ.	2	2	
2	6CB-1242F-00	GASKET, FILTER EMPAQUE DE FILTRO	2	2	
3	90105-06035	BOLT, FLANGE TORNILLO	6	6	
4	6CB-15544-00	STAY 1 SOPORTE 1	1	1	
5	90105-08178	BOLT, FLANGE TORNILLO	4	4	
<hr style="border-top: 1px dashed black;"/>					
6	6CB-1135A-00	BRACKET SOPORTE	1	1	
7	90105-06037	BOLT, FLANGE TORNILLO	4	4	
8	6CB-15142-00	GUIDE 1 GUIA 1.	1	1	
9	95D95-06016	BOLT, FLANGE DEEP RECESS CERROJO, REBORDE HUECO PROFUND	2	2	
10	6CB-1149A-00	PLATE 1 FLACA 1	1	1	
<hr style="border-top: 1px dashed black;"/>					
11	6P2-85780-01	SENSOR, KNOCK CHOCAR SENSORIO	1	1	
<hr style="border-top: 1px dashed black;"/>					
<hr style="border-top: 1px dashed black;"/>					
<hr style="border-top: 1px dashed black;"/>					
<hr style="border-top: 1px dashed black;"/>					

FIG. 7 CYLINDER & CRANKCASE 4

CILINDRO & CARTER 4

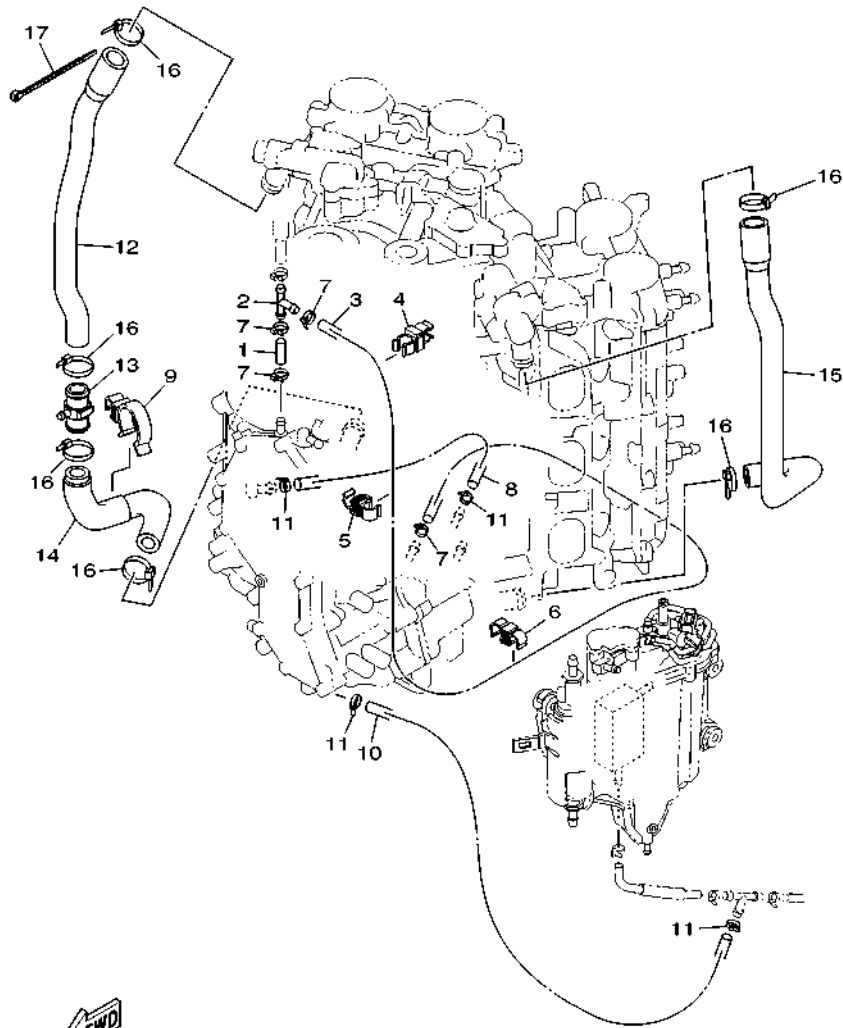

6JD1200-T070

REF. NO.	PART NO. CODIGO N°	DESCRIPTION DESCRIPCION	6KFS	6KGS		REMARKS OBSERVACIONES
1	90445-09220	HOSE (L30) TUBO (L30)	1	1		
2	688-24378-00	PIPE, JOINT 3 TUBO DE UNION 3	1	1		
3	6KA-12576-00	HOSE 1 MANGUERA 1	1	1		
4	90464-10M59	CLAMP BRIDA	1	1		
5	90464-09013	CLAMP BRIDA	1	1		
6	90464-12010	CLAMP BRIDA	1	1		
7	90465-11M10	CLAMP BRIDA	4	4		
8	6CB-12577-00	HOSE 2 MANGUERA 2	1	1		
9	90464-26002	CLAMP BRIDA	1	1		
10	90445-096H2	HOSE (L280) TUBO (L280)	1	1		
11	90465-11M10	CLAMP BRIDA	4	4		
12	6CE-1244G-00	HOSE, 4 MANGUERA 4	1	1		
13	6CE-24378-00	PIPE, JOINT 3 TUBO DE UNION 3	1	1		
14	6CE-1244H-00	HOSE 5 TUBO 5	1	1		
15	6CB-1243E-00	HOSE 2 TUBO 2	1	1		
16	90465-11M59	CLAMP BRIDA	6	6		
17	90465-14M66	CLAMP BRIDA	1	1		

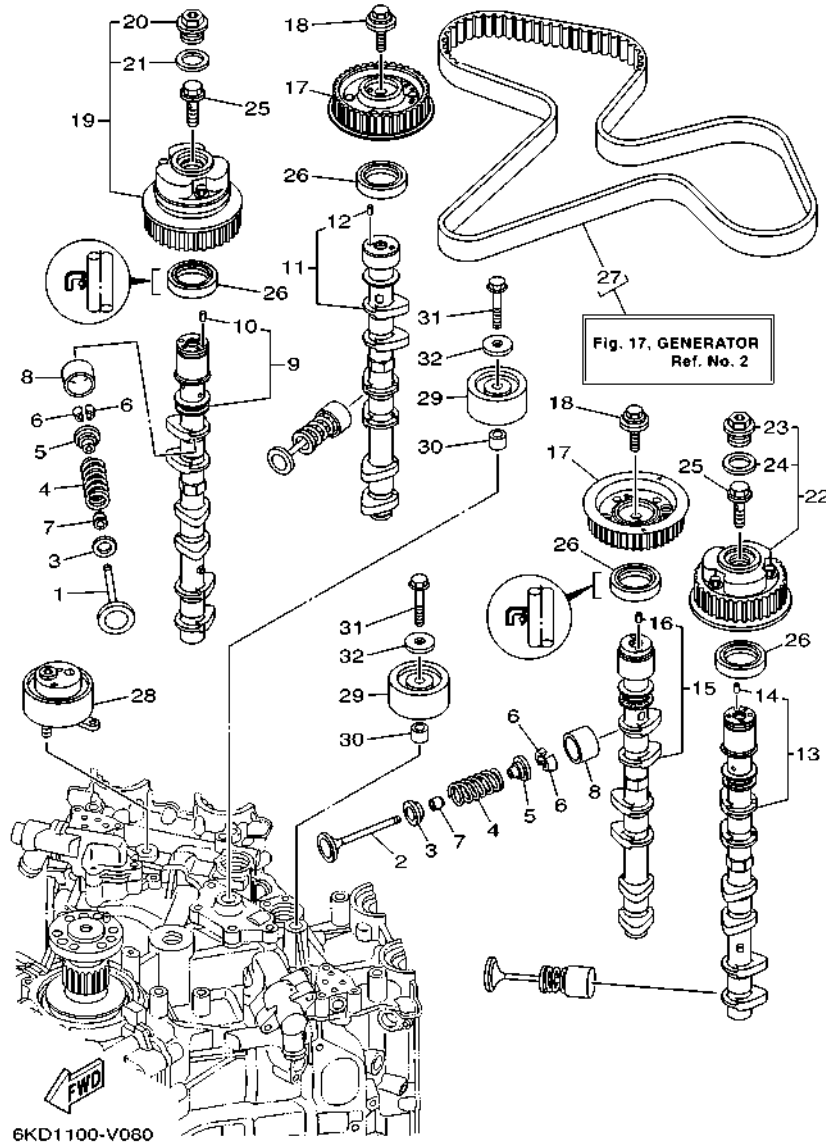

6KD1100-V080

FIG. 8 VALVE

VALVULA

REF. NO.	PART NO. CODIGO N°	DESCRIPTION DESCRIPCION	6KFS	6KGS	REMARKS OBSERVACIONES
1	6CB-12111-00	VALVE, INTAKE VALVULA DE ADMISION	12	12	
2	6DA-12121-00	VALVE, EXHAUST VALVULA DE ESCAPE	12	12	
3	K0F-A3743-00	SEAT, VALVE SPRING ASIENTO RESORTE DE VALVULA	24	24	
4	6CB-12113-00	SPRING, VALVE INNER RESORTE VALVULA INTERNA	24	24	
5	K0F-A3741-00	RETAINER, VALVE SPRING RETEN RESORTE DE VALVULA	24	24	
6	K0F-A3742-00	LOCK, VALVE SPRING RETAINER SEGURO DE VALVULA	48	48	
7	51Y-12119-00	SEAL, VALVE STEM SELLO DE ACEITE VALVULA	24	24	
8	K0F-A3751-00	LIFTER, VALVE (3.000) LEVANTADOR DE VALVULA (3.000)	24	24	UR
	K0F-A3751-10	LIFTER, VALVE (3.025) LEVANTADOR DE VALVULA (3.025)	24	24	UR
	K0F-A3751-20	LIFTER, VALVE (3.050) LEVANTADOR DE VALVULA (3.050)	24	24	UR
	K0F-A3751-30	LIFTER, VALVE (3.075) LEVANTADOR DE VALVULA (3.075)	24	24	UR
	K0F-A3751-40	LIFTER, VALVE (3.100) LEVANTADOR DE VALVULA (3.100)	24	24	UR
	K0F-A3751-50	LIFTER, VALVE (3.122) LEVANTADOR DE VALVULA (3.122)	24	24	UR
	K0F-A3751-60	LIFTER, VALVE (3.142) LEVANTADOR DE VALVULA (3.142)	24	24	UR
	K0F-A3751-70	LIFTER, VALVE (3.162) LEVANTADOR DE VALVULA (3.162)	24	24	UR
	K0F-A3751-80	LIFTER, VALVE (3.182) LEVANTADOR DE VALVULA (3.182)	24	24	UR
	K0F-A3751-90	LIFTER, VALVE (3.202) LEVANTADOR DE VALVULA (3.202)	24	24	UR
	K0F-A3751-A0	LIFTER, VALVE (3.222) LEVANTADOR DE VALVULA (3.222)	24	24	UR
	K0F-A3751-B0	LIFTER, VALVE (3.242) LEVANTADOR DE VALVULA (3.242)	24	24	UR
	K0F-A3751-C0	LIFTER, VALVE (3.262) LEVANTADOR DE VALVULA (3.262)	24	24	UR
	K0F-A3751-D0	LIFTER, VALVE (3.282) LEVANTADOR DE VALVULA (3.282)	24	24	UR
	K0F-A3751-E0	LIFTER, VALVE (3.302) LEVANTADOR DE VALVULA (3.302)	24	24	UR
	K0F-A3751-F0	LIFTER, VALVE (3.322) LEVANTADOR DE VALVULA (3.322)	24	24	UR
	K0F-A3751-G0	LIFTER, VALVE (3.342) LEVANTADOR DE VALVULA (3.342)	24	24	UR
	K0F-A3751-H0	LIFTER, VALVE (3.362) LEVANTADOR DE VALVULA (3.362)	24	24	UR
	K0F-A3751-J0	LIFTER, VALVE (3.382) LEVANTADOR DE VALVULA (3.382)	24	24	UR
	K0F-A3751-K0	LIFTER, VALVE (3.402) LEVANTADOR DE VALVULA (3.402)	24	24	UR

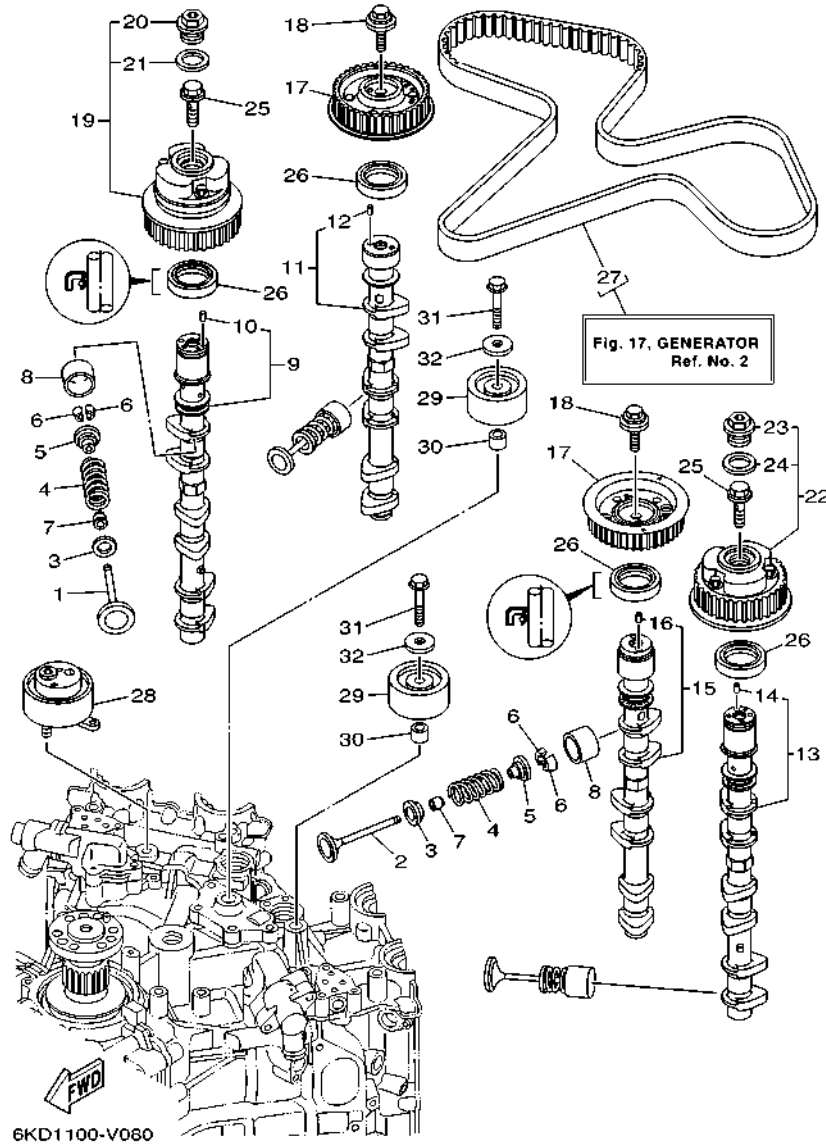

6KD1100-V080

FIG. 8 VALVE

VALVULA

REF. NO.	PART NO. CODIGO N°	DESCRIPTION DESCRIPCION	6KFS	6KG3	REMARKS OBSERVACIONES
8	K0F-A3751-L0	LIFTER, VALVE (3.422) LEVANTADOR DE VALVULA (3.422)	24	24	UR
	K0F-A3751-M0	LIFTER, VALVE (3.442) LEVANTADOR DE VALVULA (3.442)	24	24	UR
	K0F-A3751-N0	LIFTER, VALVE (3.462) LEVANTADOR DE VALVULA (3.462)	24	24	UR
	K0F-A3751-P0	LIFTER, VALVE (3.482) LEVANTADOR DE VALVULA (3.482)	24	24	UR
	K0F-A3751-R0	LIFTER, VALVE (3.502) LEVANTADOR DE VALVULA (3.502)	24	24	UR
	K0F-A3751-S0	LIFTER, VALVE (3.522) LEVANTADOR DE VALVULA (3.522)	24	24	UR
	K0F-A3751-T0	LIFTER, VALVE (3.542) LEVANTADOR DE VALVULA (3.542)	24	24	UR
	K0F-A3753-00	LIFTER, VALVE (3.562) LEVANTADOR DE VALVULA (3.562)	24	24	UR
	K0F-A3753-10	LIFTER, VALVE (3.582) LEVANTADOR DE VALVULA (3.582)	24	24	UR
	K0F-A3753-20	LIFTER, VALVE (3.602) LEVANTADOR DE VALVULA (3.602)	24	24	UR
	K0F-A3753-30	LIFTER, VALVE (3.625) LEVANTADOR DE VALVULA (3.625)	24	24	UR
	K0F-A3753-40	LIFTER, VALVE (3.650) LEVANTADOR DE VALVULA (3.650)	24	24	UR
	K0F-A3753-50	LIFTER, VALVE (3.675) LEVANTADOR DE VALVULA (3.675)	24	24	UR
	K0F-A3753-60	LIFTER, VALVE (3.700) LEVANTADOR DE VALVULA (3.700)	24	24	UR
	K0F-A3753-70	LIFTER, VALVE (3.725) LEVANTADOR DE VALVULA (3.725)	24	24	UR
9	6KA-12171-00	CAMSHAFT 1 ARBOL DE LEVAS 1	1	1	
10	93605-10108	.PIN, DOWEL .PASADOR DE CLAVIJA	1	1	
11	6KA-12181-00	CAMSHAFT 2 ARBOL DE LEVAS 2	1	1	
12	93605-10108	.PIN, DOWEL .PASADOR DE CLAVIJA	1	1	
13	6KA-12172-00	CAMSHAFT 3 ARBOL DE LEVAS 3	1	1	
14	93605-10108	.PIN, DOWEL .PASADOR DE CLAVIJA	1	1	
15	6KA-12182-00	CAMSHAFT 4 ARBOL DE LEVAS 4	1	1	
16	93605-10108	.PIN, DOWEL .PASADOR DE CLAVIJA	1	1	
17	6KA-11567-00	GEAR, DRIVEN 2 ENGRANAJE TRACCION 2	2	2	
18	90119-10050	BOLT, WITH WASHER TORNILLO CON ARANDELA	2	2	
19	6CB-12645-01	PULLEY ASSY 1 POLEA COMPL. 1	1	1	
20	6P2-12623-00	.BOLT .PERNO	1	1	

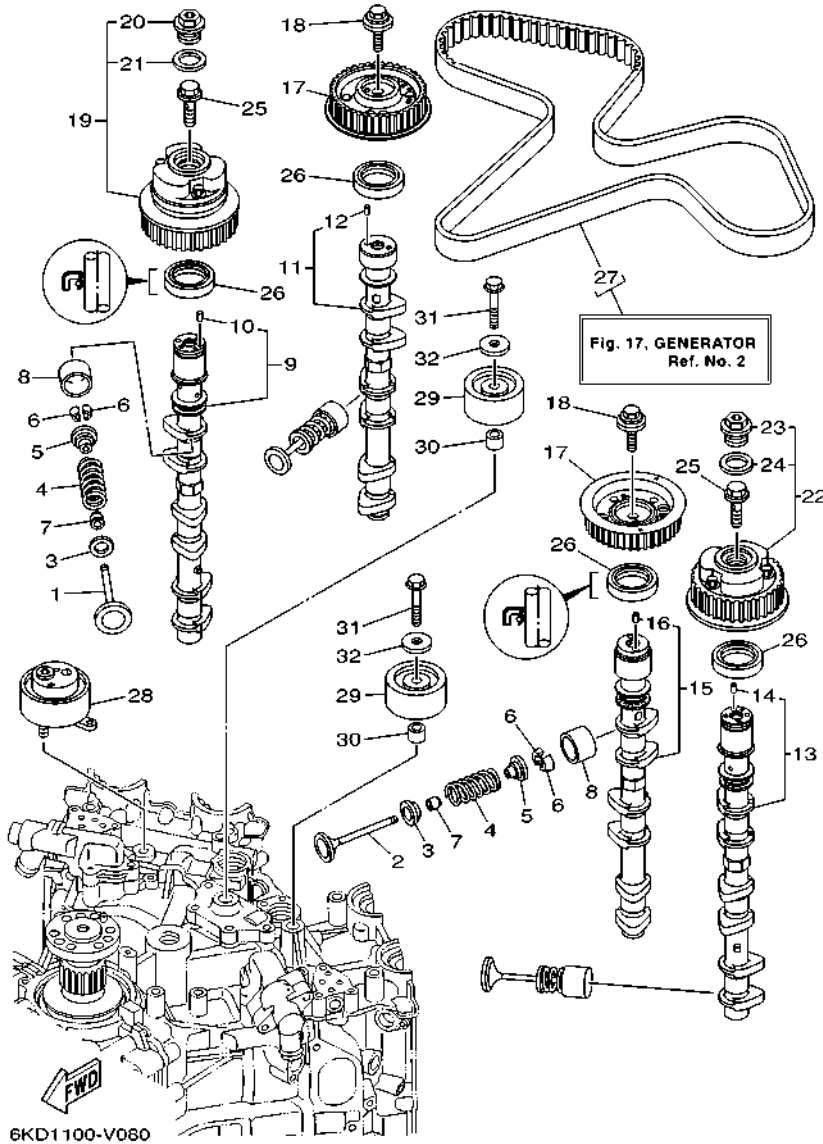

6KD1100-V060

FIG. 8 VALVE

VALVULA

REF. NO.	PART NO. CODIGO N°	DESCRIPTION DESCRIPCION	6KF3	6KG3	REMARKS OBSERVACIONES
21	6P2-12663-00	.GASKET .EMPAQUE	1	1	
22	6CB-1264A-01	PULLEY ASSY 2 POLEA COMPL. 2	1	1	
23	6P2-12623-00	.BOLT .PERNO	1	1	
24	6P2-12663-00	.GASKET .EMPAQUE	1	1	
25	6P2-12615-00	BOLT PERNO	2	2	
26	93102-38008	OIL SEAL SELLO ACEITE	4	4	
27	6CB-W4624-00	BELT (WITH ROTOR BOLTS) CORREA (CON PERNO)	1	1	
28	6CB-11590-03	TENSIONER ASSY TENSOR COMPLET	1	1	
29	6CB-15512-00	GEAR, IDLER 1 ENGRENAJE NEUTRO	2	2	
30	99530-14016	PIN, DOWEL PASADOR, DE ESPIGA	2	2	
31	90119-10M07	BOLT, WITH WASHER TORNILLO CON ARANDELA	2	2	
32	90201-10M01	WASHER, PLATE ARANDELA PLANA	2	2	

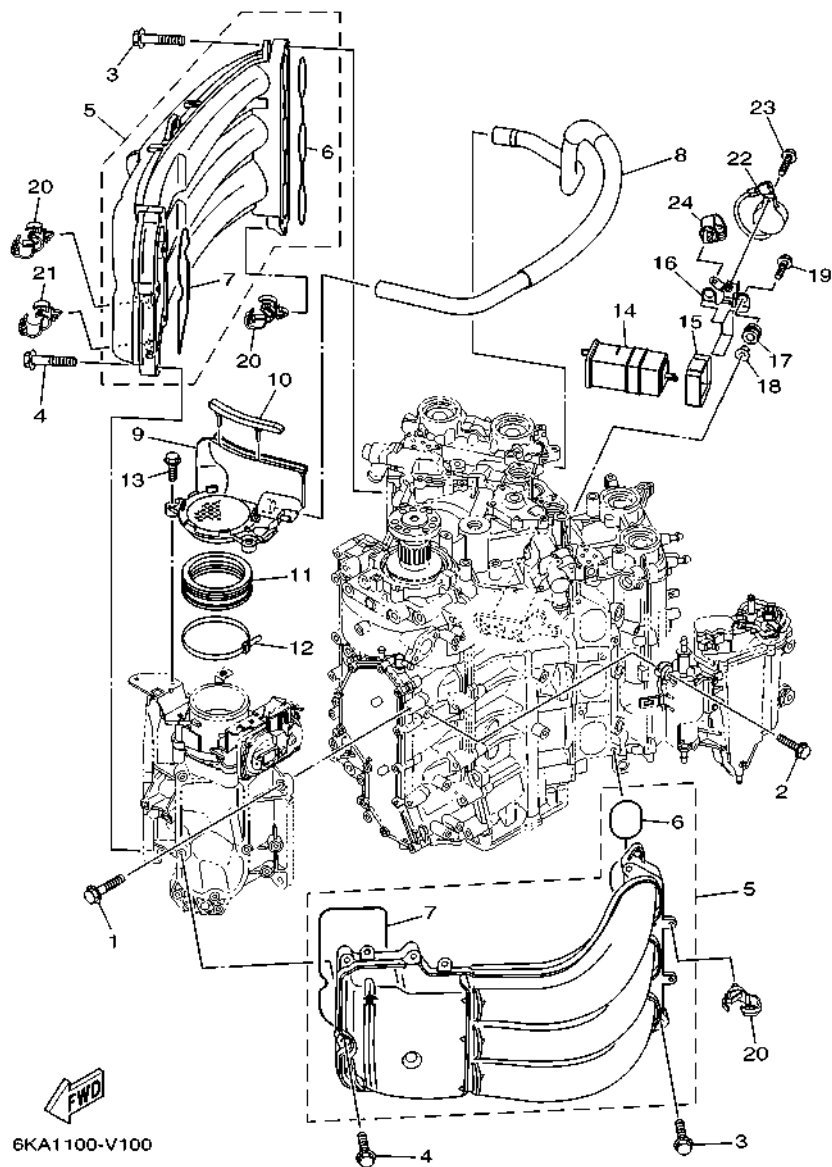

FIG. 9 INTAKE 1

ADMISION 1

REF. NO.	PART NO. CODIGO N°	DESCRIPTION DESCRIPCION	6KFS	6KGS	REMARKS OBSERVACIONES
1	95D75-08030	BOLT, FLANGE DEEP RECESS CERROJO, REBORDE HUECO PROFUND	4	4	
2	90119-06299	BOLT, WITH WASHER TORNILLO CON ARANDELA	4	4	
3	90119-08020	BOLT, WITH WASHER TORNILLO CON ARANDELA	8	8	
4	90105-06035	BOLT, FLANGE TORNILLO	10	10	
5	6CE-13641-00	MANIFOLD, INTAKE 1 CONECTOR DE ADMISION 1	2	2	
6	6CB-13645-00	.GASKET, MANIFOLD 1 .EMPAQUE	1	1	
7	6CB-13646-00	.GASKET, MANIFOLD 2 .EMPAQ. DE MULTIPLE 2	1	1	
8	6CB-15373-01	PIPE, BREATHER MANGUELA DE RESPIRADERO	1	1	
9	6CB-14440-01	SILENCER ASSY, INTAKE SILENCIADOR COMPL DE ADMISION	1	1	
10	6CB-85547-00	DAMPER AMORTIGUADOR	1	1	
11	6AW-1441J-01	PIPE, SILENCER TUBO	1	1	
12	90464-99004	CLAMP BRIDA	1	1	
13	95D95-06025	BOLT, FLANGE DEEP RECESS CERROJO, REBORDE HUECO PROFUND	2	2	
14	69J-24170-00	CANISTER ASSY FRANJA DE DEPOSITO DE COMBUST.	1	1	
15	6FP-2419E-01	COVER, CANISTER CUBIERTA	1	1	
16	6KA-2134X-00	BRACKET, CANISTER SOPORTE	1	1	
17	90480-10M23	GROMMET TAPON	2	2	
18	90387-06289	COLLAR ESPACIADOR	2	2	
19	90119-06309	BOLT, WITH WASHER TORNILLO CON ARANDELA	2	2	
20	90464-13249	CLAMP BRIDA	8	8	
21	90464-20181	CLAMP BRIDA	1	1	
22	6KA-83383-01	BUZZER ZUMBADOR	1	1	
23	90119-05M04	BOLT, WITH WASHER TORNILLO CON ARANDELA	1	1	
24	90464-13249	CLAMP BRIDA	1	1	

FIG. 10 INTAKE 2

ADMISION 2

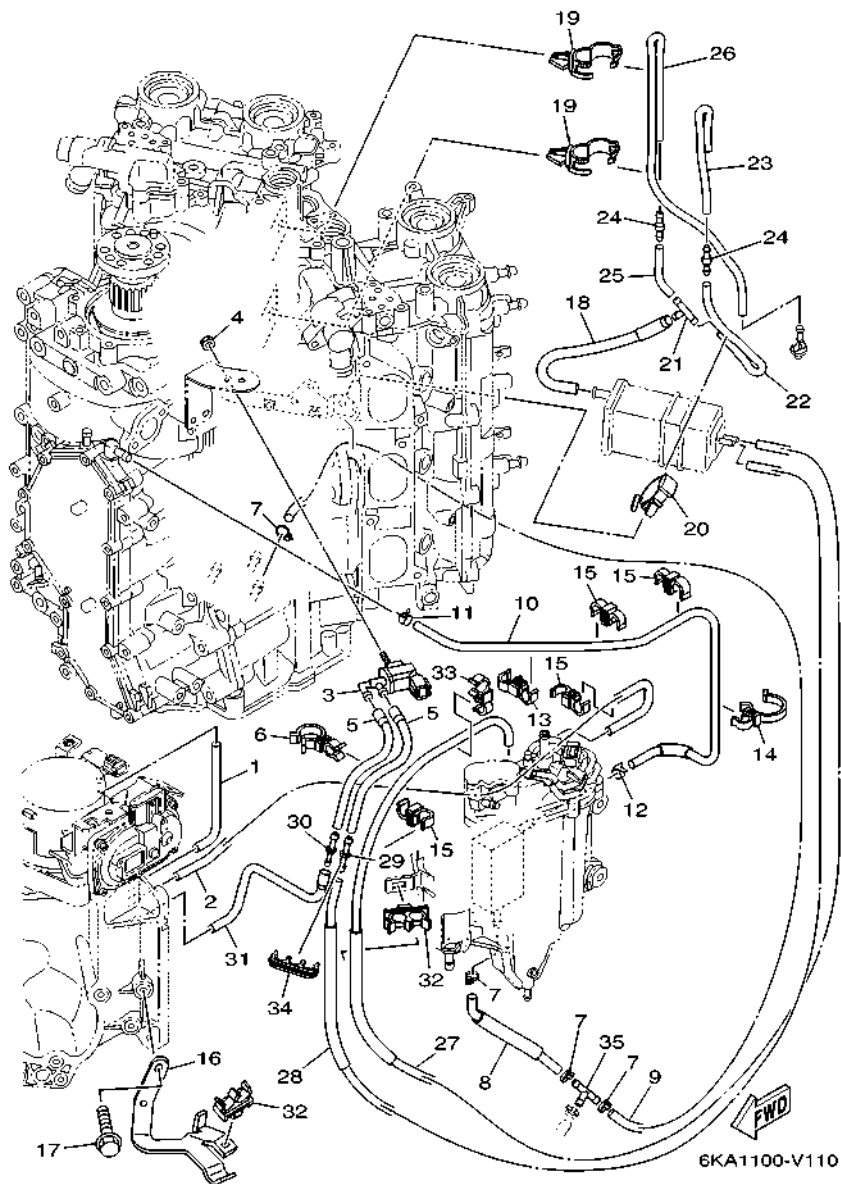

REF. NO.	PART NO. CODIGO N°	DESCRIPTION DESCRIPCION	6KFS	6KGS	REMARKS OBSERVACIONES
1	6CB-13533-00	HOSE, VACUUM SENSING 4 MANGUERA, DE VACIO 4	1	1	
2	6CB-13532-10	HOSE, VACUUM SENSING 3 MANGUERA, DE VACIO 3	1	1	
3	6C5-86120-00	SOLENOID VALVE ASSY VALVULA SOLENOIDE CONJ.	1	1	
4	95380-06600	NUT, HEXAGON TUERCA	1	1	
5	6CB-2416A-00	HOSE TUBO DE COMBUSTIBLE	2	2	
6	90464-23001	CLAMP BRIDA	2	2	
7	90465-11M10	CLAMP BRIDA	4	4	
8	6CE-12482-10	PIPE 2 TUBO 2	1	1	
9	90445-09120	HOSE (L600) TUBO (L600)	1	1	
10	6CB-12484-00	PIPE 4 TUBO 4	1	1	
11	90467-090A0	CLIP PRESILLA	1	1	
12	90465-11M10	CLAMP BRIDA	1	1	
13	90464-12010	CLAMP BRIDA	1	1	
14	90464-26002	CLAMP BRIDA	1	1	
15	90464-09013	CLAMP BRIDA	4	4	
16	6CB-13782-00	STAY SOPORTE	1	1	
17	95D95-06016	BOLT, FLANGE DEEP RECESS CERROJO, REBORDE HUECO PROFUND	2	2	
18	6CB-13545-00	HOSE 1 SELLO	1	1	
19	90464-20181	CLAMP BRIDA	2	2	
20	90464-07209	CLAMP BRIDA	1	1	
21	688-24378-00	PIPE, JOINT 3 TUBO DE UNION 3	1	1	
22	6CB-13546-01	HOSE 2 SELLO	1	1	
23	6CB-13547-00	HOSE 3 SELLO	1	1	
24	6E5-21744-00	BREATHER RESPIRADERO	2	2	
25	6CB-13548-00	HOSE, AIR 4 TUBO DE AIRE 4	1	1	
26	6KA-12483-00	PIPE 3 TUBO 3	1	1	
27	6KA-1475A-00	PIPE 1 TUBO 1	1	1	

FIG. 10 INTAKE 2

ADMISION 2

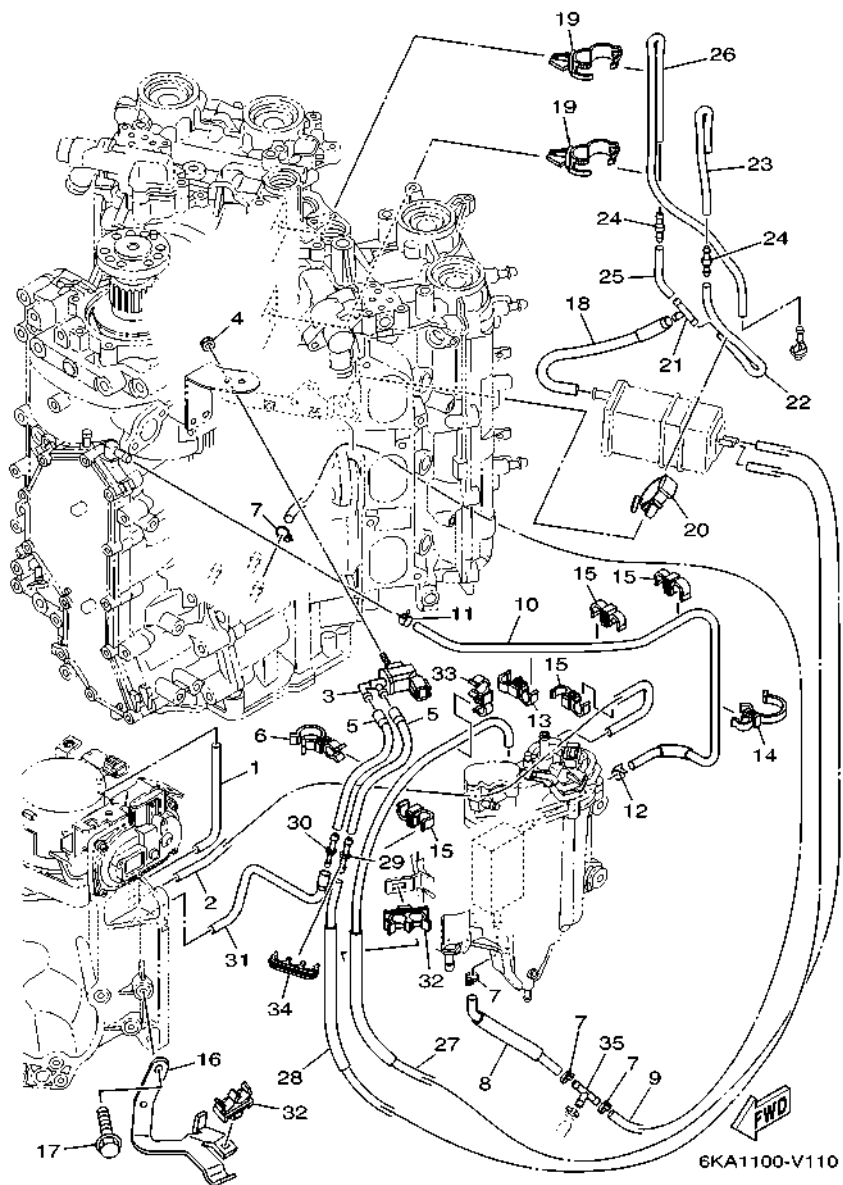

REF. NO.	PART NO. CODIGO N°	DESCRIPTION DESCRIPCION	6KF3	6KG3		REMARKS OBSERVACIONES
28	6KA-1475F-00	PIPE 3 TUBO 3	1	1		
29	6G8-24376-00	PIPE, JOINT 1 TUBO DE UNION 1	1	1		
30	6EK-14989-00	ORIFICE, AIR VENT ORIFICIO DE VENTILACION	1	1		
31	6CB-1475G-10	PIPE 4 TUBO 4	1	1		
32	90464-11012	CLAMP BRIDA	2	2		
33	90464-12010	CLAMP BRIDA	1	1		
34	90464-10011	CLAMP BRIDA	1	1		
35	688-24378-00	PIPE, JOINT 3 TUBO DE UNION 3	1	1		

FIG. 11 THROTTLE BODY ASSY 1

CAJA DE ACELERADOR COMPL 1

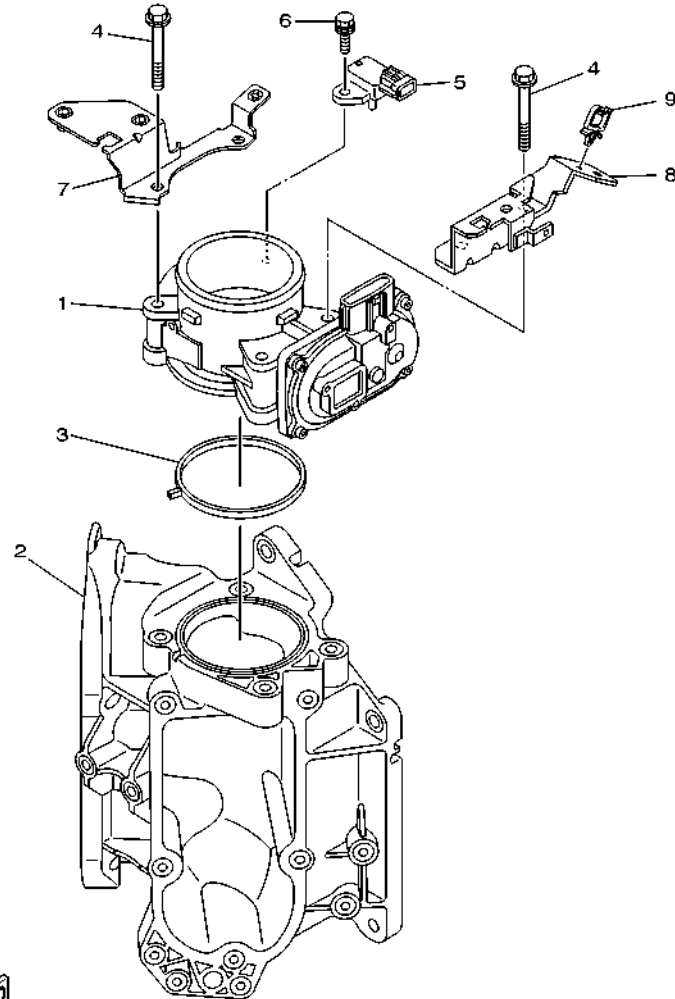

6KA1100-V120

REF. NO.	PART NO. CODIGO N°	DESCRIPTION DESCRIPCION	6KFS	6KGS	REMARKS OBSERVACIONES
1	6CB-13751-11	BODY, THROTTLE 1 CAJA 1	1	1	
2	6CB-13711-00	MIXING BODY CUERPO DE MEZCLA	1	1	
3	6CB-13556-00	GASKET, MANIFOLD EMPAQUE	1	1	
4	95D75-08060	BOLT, FLANGE DEEP RECESS CERROJO, REBORDE HUECO PROFUND	4	4	
5	6P2-82380-00	SENSOR, PRESSURE SENSOR DE PRESION	1	1	
6	97E75-06620	BOLT, HEXAGON W/W DEEP RECESS TORNILLO HEXAGONAL CON RONDONA	1	1	
7	6KA-13898-00	HOLDER SOSTEN	1	1	
8	6CB-13898-11	HOLDER SOSTEN	1	1	
9	90464-08004	CLAMP BRIDA	1	1	

FIG. 12 THROTTLE BODY ASSY 2

CAJA DE ACELERADOR COMPL 2

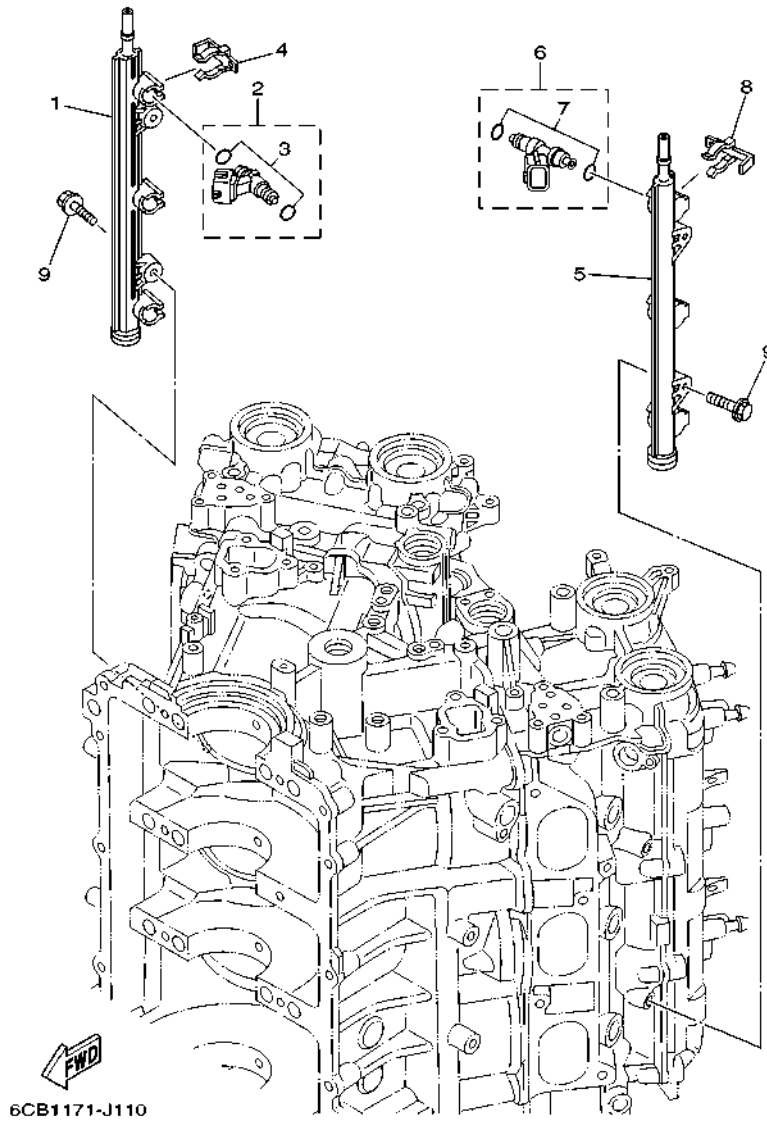

REF. NO.	PART NO. CODIGO N°	DESCRIPTION DESCRIPCION	6KF3	6KG3	REMARKS OBSERVACIONES
1	6CB-13161-11	PIPE, DELIVERY 1 TUBO CONDUCTOR 1	1	1	
2	6AW-13761-01	INJECTOR INYECTOR	3	3	
3	6AW-1410B-00	.PACKING KIT .JUEGO DE EMPAQUE	1	1	
4	6CB-13577-00	CLIP PRESILLA	3	3	
5	6CB-13171-11	PIPE, DELIVERY 2 TUBO CONDUCTOR 2	1	1	
6	6AW-13761-01	INJECTOR INYECTOR	3	3	
7	6AW-1410B-00	.PACKING KIT .JUEGO DE EMPAQUE	1	1	
8	6CB-13577-00	CLIP PRESILLA	3	3	
9	90105-06M08	BOLT, FLANGE TORNILLO	4	4	

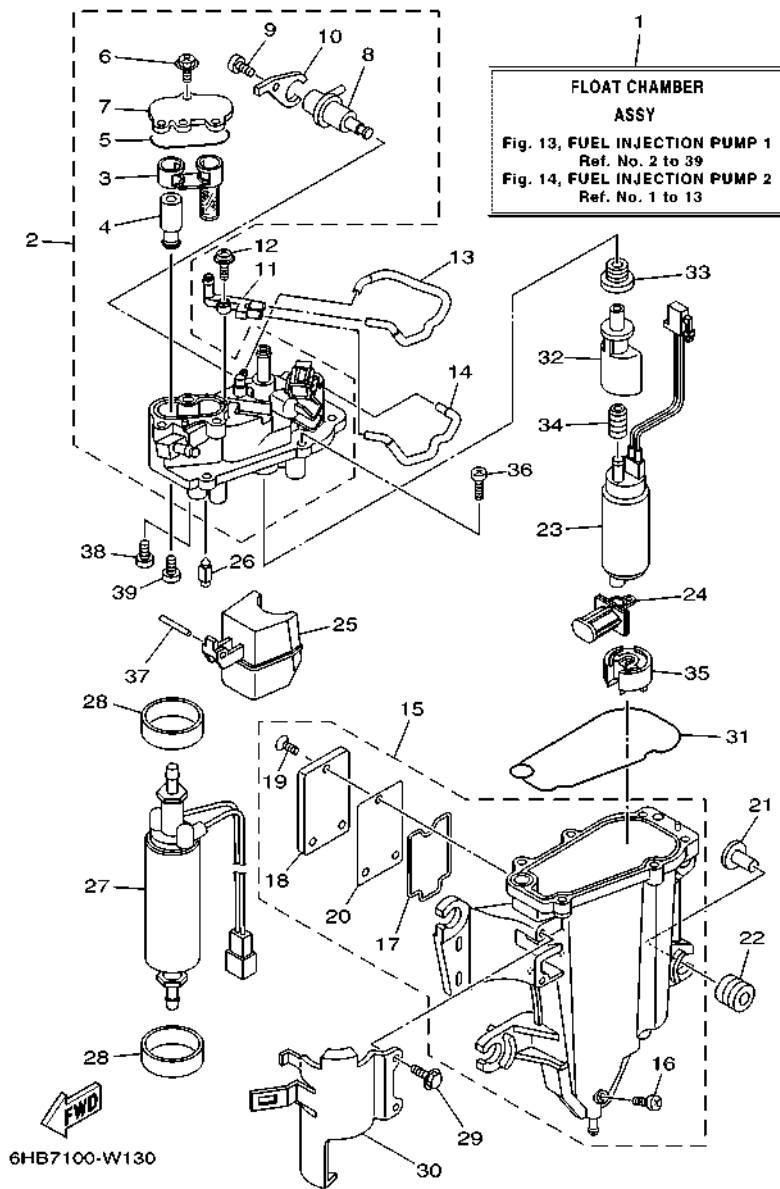

FIG. 13 FUEL INJECTION PUMP 1

BOMBA DE INYECTOR 1

REF. NO.	PART NO. CODIGO N°	DESCRIPTION DESCRIPCION	6KFS	6KGS	REMARKS OBSERVACIONES
1	6CB-14180-14	FLOAT CHAMBER ASSY CAMARA DE BOYA COMPLETE	1	1	EXCEPT FOR BRA
	6CB-14180-24	FLOAT CHAMBER ASSY CAMARA DE BOYA COMPLETE	1	1	EXCEPT FOR BRA
2	6CB-14182-02	COVER, FLOAT CHAMBER TAPA DE CAMARA DE BOIA	1	1	FOR BRA
	6CB-14182-20	COVER, FLOAT CHAMBER TAPA DE CAMARA DE BOIA	1	1	EXCEPT FOR BRA
3	6CB-24501-01	.FILTER, FUEL .FIELTRO	1	1	FOR BRA
4	6CB-24460-00	.RELIEF VALVE ASSY .VALVELA DE DESCOMPRESION	1	1	EXCEPT FOR BRA
	6CB-24460-10	.RELIEF VALVE ASSY .VALVELA DE DESCOMPRESION	1	1	EXCEPT FOR BRA
5	6CB-13016-00	.O-RING .ANILLO O	1	1	FOR BRA
6	6CB-14216-00	.SCREW .TORNILLO	3	3	FOR BRA
7	6CB-24217-00	.COVER .CUBIERTA	1	1	EXCEPT FOR BRA
	6CB-24217-10	.COVER .CUBIERTA	1	1	EXCEPT FOR BRA
8	6CB-13906-01	.REGULATOR, PRESSURE .REGULADOR	1	1	FOR BRA
9	6CB-14564-00	.SCREW .TORNILLO	1	1	FOR BRA
10	6CB-14146-00	.PLATE .PLACA SOPORTE	1	1	
11	68V-24379-10	PIPE, JOINT 4 TUBO DE UNION 4	1	1	
12	68V-14216-00	SCREW TORNILLO	1	1	
13	6CB-1475H-00	PIPE 5 TUBO 5	1	1	
14	6CB-1475J-00	PIPE 6 TUBO 6	1	1	
15	6CB-14181-01	BODY, FLOAT CHAMBER 1 CUERPO DE CAMARA DE BOIA	1	1	
16	6P2-14191-00	.PLUG, DRAIN .TORNILLO, DE DRENAJE	1	1	
17	6CB-14239-00	.SEAL .SELLO	1	1	
18	6CB-24452-10	.COVER .CUBIERTA	1	1	
19	6CB-14429-01	.SCREW .TORNILLO	3	3	
20	6CB-24482-00	.GASKET 1 .EMPAQUE 1	1	1	
21	63P-13716-00	COLLAR COLLAR	4	4	
22	6CB-13593-00	DAMPER COJINETE DE RODILLOS	4	4	
23	6CB-13907-12	FUEL PUMP COMP. BOMBA DE COMBUSTIBLE COMPLETA	1	1	EXCEPT FOR BRA

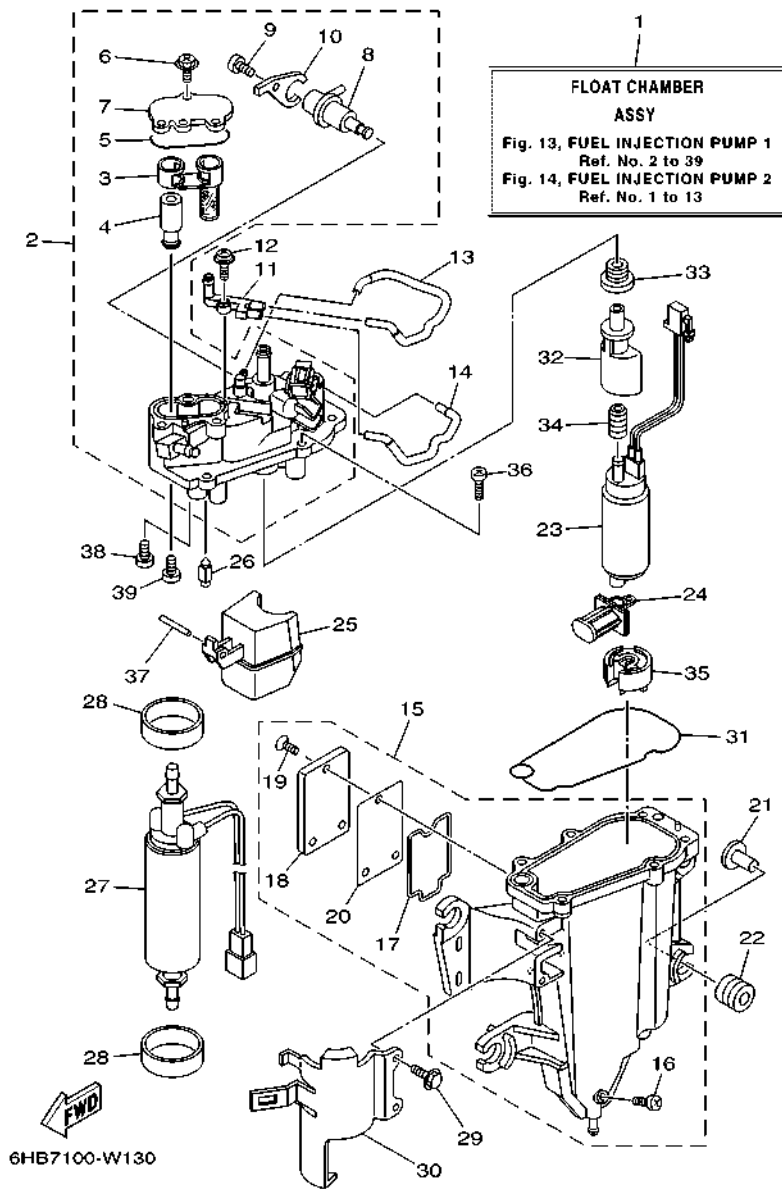

FIG. 13 FUEL INJECTION PUMP 1

BOMBA DE INYECTOR 1

REF. NO.	PART NO. CODIGO N°	DESCRIPTION DESCRIPCION	6KFS	6KGS	REMARKS OBSERVACIONES
23	6CB-13907-22	FUEL PUMP COMP. BOMBA DE COMBUSTIBLE COMPLETA	1	1	FOR BRA FOR BRA
24	63P-13915-00	FILTER FILTRO	1	1	
25	6CB-14985-00	FLOAT BOIA	1	1	
26	6CB-14546-00	VALVE, NEEDLE VALVULA DE AGUJA	1	1	
27	6GR-24410-01	FUEL PUMP ASSY BOMBA DE COMBUSTIBLE COMPLETA	1	1	
28	6CB-24492-00	BUSH, FUEL PUMP BUJE	2	2	
29	6CB-24592-00	BOLT TORNILLO	2	2	
30	6CB-24491-00	BRACKET, FUEL PUMP SOPORTE BOMBA COMBUSTIBLE	1	1	
31	6CB-14984-00	GASKET, FLOAT CHAMBER EMPAQUE CAMARA DE BOIA	1	1	
32	6AW-13132-00	JOINT JUNTA	1	1	
33	6CB-1447B-00	BUSH 1 BUJE 1	1	1	
34	6AW-13781-00	DAMPER, PUMP AMORTIGUADOR DE BOMBA	1	1	
35	6AW-13784-00	COVER, PUMP CUBIERTA DE BOMBA	1	1	
36	63P-14567-00	SCREW TORNILLO	6	6	
37	6P2-14386-00	PIN, FLOAT PASADOR DE BOIA	1	1	
38	4SV-24453-00	SCREW TORNILLO	1	1	EXCEPT FOR BRA EXCEPT FOR BRA
	69J-24453-00	SCREW TORNILLO	1	1	FOR BRA FOR BRA
39	98507-04008	SCREW, PAN HEAD TORNILLO DE CABEZA CON PLANA	1	1	EXCEPT FOR BRA EXCEPT FOR BRA
	68V-14592-10	SCREW TORNILLO	1	1	FOR BRA FOR BRA

FIG. 14 FUEL INJECTION PUMP 2

BOMBA DE INYECTOR 2

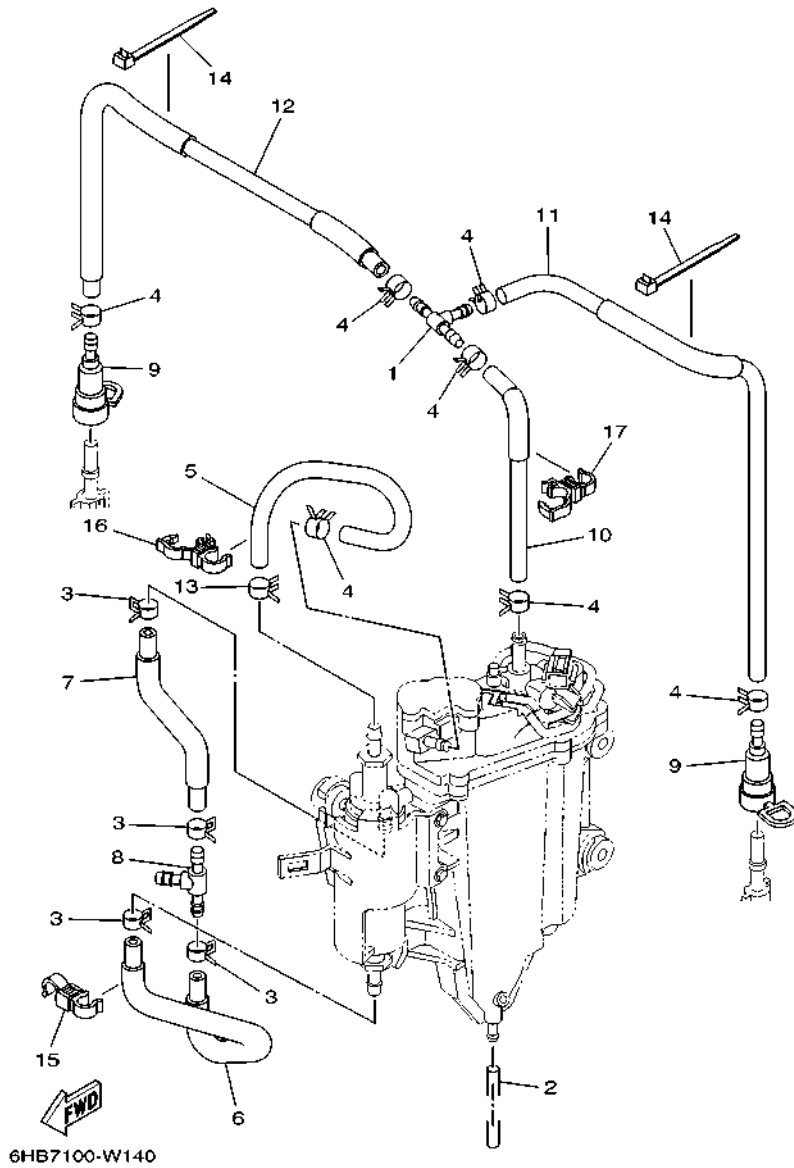

REF. NO.	PART NO. CODIGO N°	DESCRIPTION DESCRIPCION	6KFS	6KGS	REMARKS OBSERVACIONES
1	6CB-24461-00	PIPE, JOINT TUBO DE UNION	1	1	
2	6P2-14149-00	PIPE TUBO	1	1	
3	90467-141A2	CLIP PRESILLA	4	4	
4	68V-13577-01	CLIP PRESILLA	7	7	
5	6CB-24324-00	PIPE 13 TUBO 13	1	1	
6	6CB-24317-00	PIPE 7 TUBO 7	1	1	
7	6CB-24323-00	PIPE 12 TUBO 12	1	1	
8	6E5-24378-00	PIPE, JOINT 3 TUBO DE UNION 3	1	1	
9	60E-24300-01	FUEL PIPE JOINT CONECTOR MANGUERA COMBUSTIBLE	2	2	
10	6CB-13971-01	PIPE, FUEL 1 ANILLO DE ESPACIADOR	1	1	
11	6CB-13974-01	PIPE, FUEL 4 TUBO, COMBUSTIBLE 4	1	1	
12	6CB-13972-00	PIPE, FUEL 2 TUBO, COMBUSTIBLE 2	1	1	
13	90467-140A9	CLIP PRESILLA	1	1	
14	90465-14M66	CLAMP BRIDA	2	2	
15	90464-12009	CLAMP BRIDA	1	1	
16	90464-12012	CLAMP BRIDA	1	1	
17	90464-12012	CLAMP BRIDA	1	1	

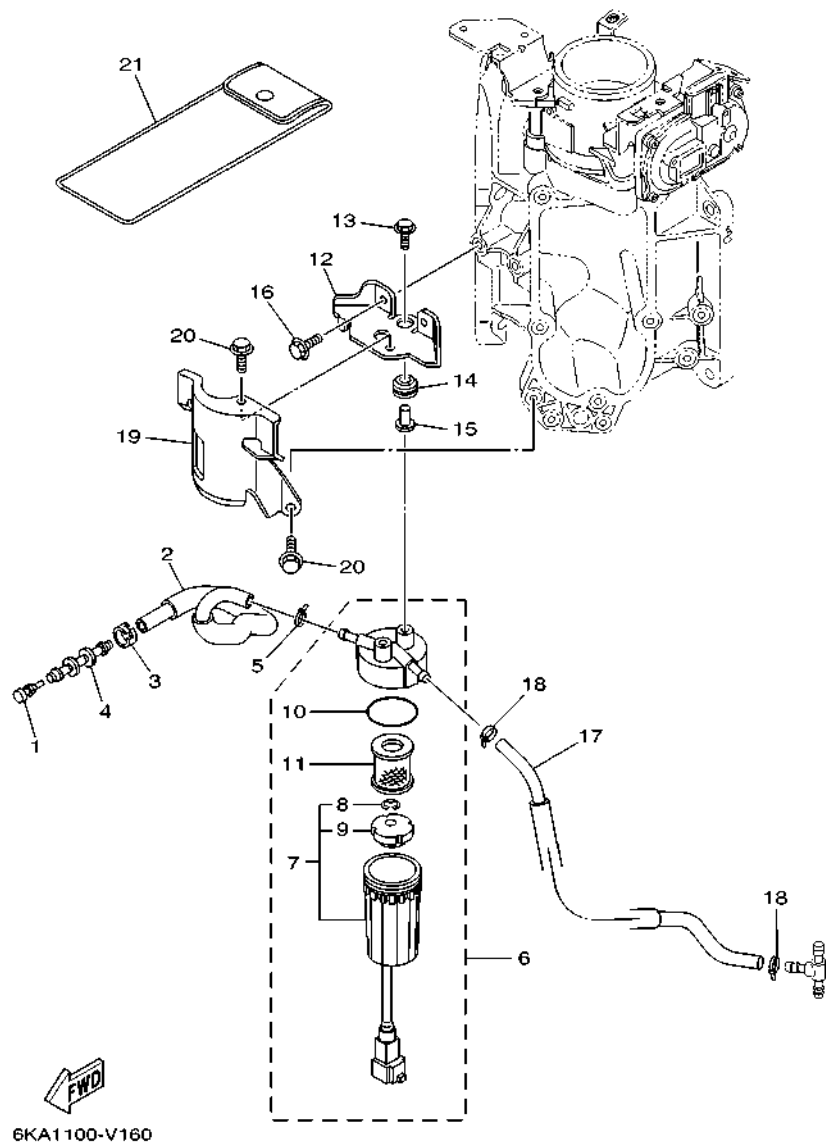

FIG. 15 FUEL 1

COMBUSTIBLE 1

REF. NO.	PART NO. CODIGO N°	DESCRIPTION DESCRIPCION	6KFS	6KGS		REMARKS OBSERVACIONES
1	689-85547-01	DAMPER AMORTIGUADOR	1	1		
2	6KA-24314-10	PIPE 4 TUBO 4	1	1		
3	6E5-24351-51	BAND 1 ABRAZADERA 1	1	1		
4	6AW-24377-01	PIPE, JOINT 2 TUBO DE UNION 2	1	1		
5	90465-11M10	CLAMP BRIDA	1	1		
6	6P3-24560-23	FILTER ASSY FILTRO COMPLETO	1	1		
7	6P3-24562-21	.CUP, FILTER .COPA DE FILTRO	1	1		
8	6P3-24519-00	.CLIP .PRESILLA	1	1		
9	6P3-24469-00	.FLOAT, WATER LEVEL .BOIA	1	1		
10	6P3-24564-00	.GASKET .EMPAQUE	1	1		
11	6P3-24563-02	.ELEMENT, FILTER .ELEMENTO DEL FILTRO	1	1		
12	6CB-24566-00	BRACKET, FILTER SOPORTE DEL FILTRO	1	1		
13	90119-06309	BOLT, WITH WASHER TORNILLO CON ARANDELA	2	2		
14	90480-10M23	GROMMET TAPON	2	2		
15	90387-06289	COLLAR ESPACIADOR	2	2		
16	95D95-06016	BOLT, FLANGE DEEP RECESS CERROJO, REBORDE HUECO PROFUND	2	2		
17	6CB-24313-10	PIPE 3 TUBO 3	1	1		
18	90465-11M10	CLAMP BRIDA	2	2		
19	6CB-24596-01	COVER CUBIERTA	1	1		
20	95D95-06014	BOLT, FLANGE DEEP RECESS CERROJO, REBORDE HUECO PROFUND	2	2		
21	69J-28100-03	TOOL KIT JUEGO DE HERRAMIENTAS	1	1		AP AP

FIG. 16 FUEL 2

COMBUSTIBLE 2

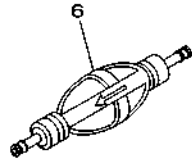
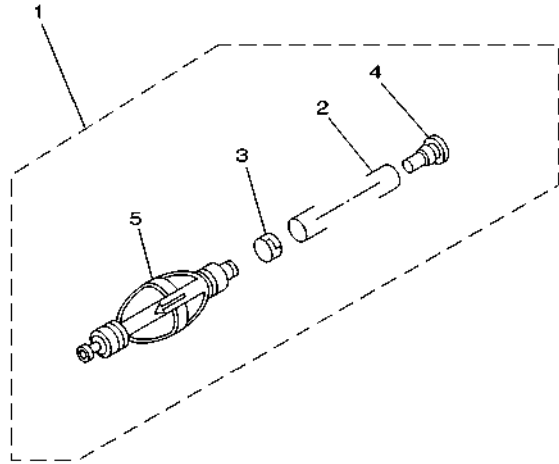

REF. NO.	PART NO. CODIGO N°	DESCRIPTION DESCRIPCION	6KFS	6KG3	REMARKS OBSERVACIONES
1	6Y2-24307-51	FUEL PIPE COMP. 2 MANGUERA COMPL, COMBUSTIBLE 2	1	1	AP EXCEPT FOR CAR AP EXCEPT FOR CAR
2	90445-13M01	.HOSE (L2050) .MANGUERA (L2050)	1	1	
3	6E5-24351-51	.BAND 1 .ABRAZADERA 1	1	1	
4	90480-06M19	.GROMMET .TAPON	1	1	
5	6Y2-24360-60	.PRIMER PUMP ASSY .SOPORTE BOMBA	1	1	
6	6AW-24360-02	PRIMER PUMP ASSY SOPORTE BOMBA	1	1	AP FOR CAR AP FOR CAR



68V9100-J110

FIG. 17 GENERATOR

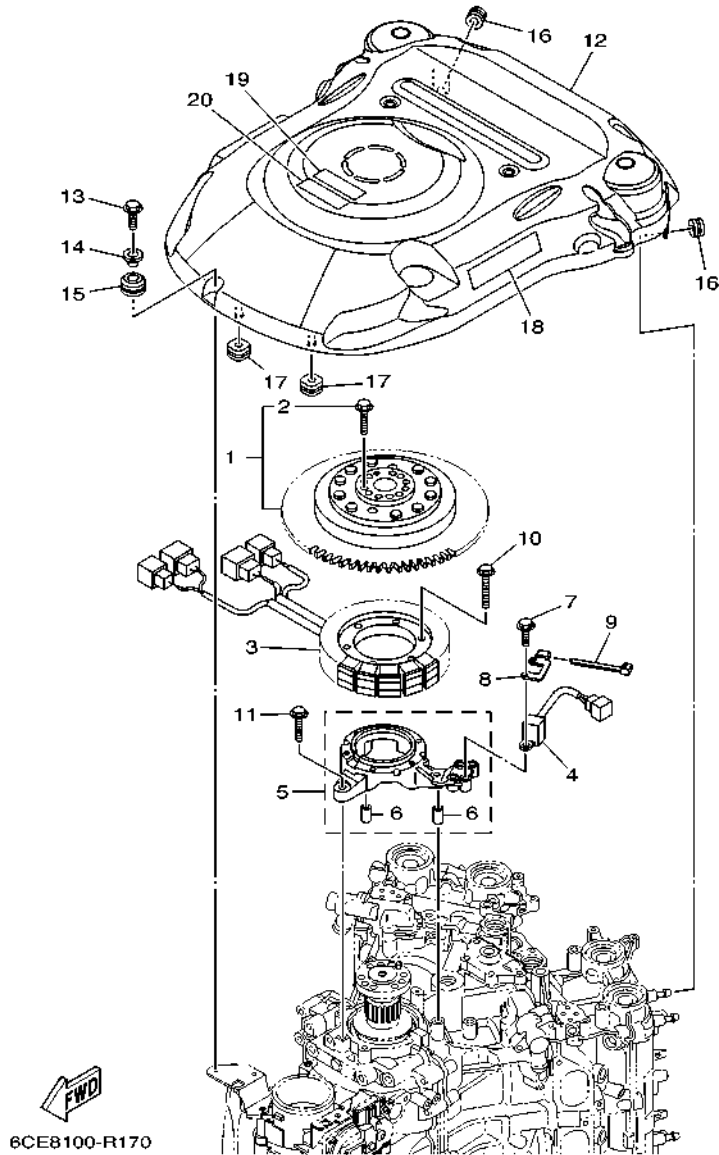
GENERADOR

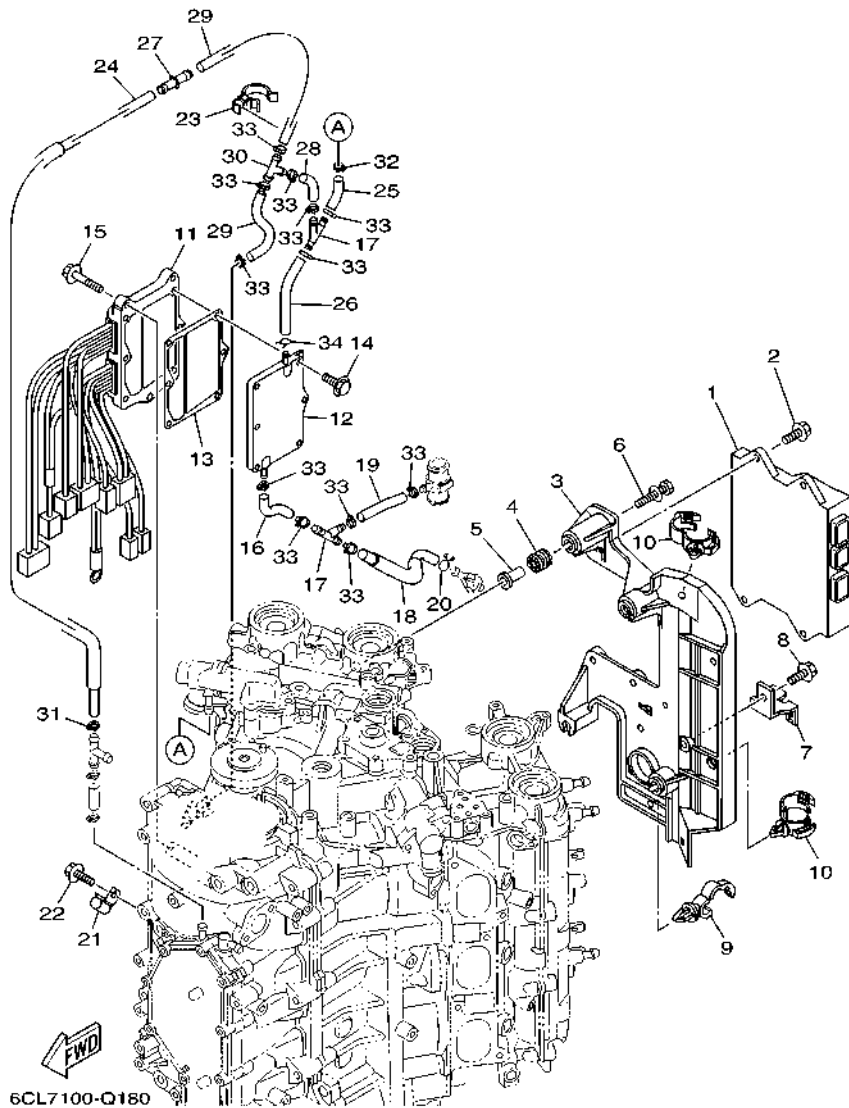

REF. NO.	PART NO. CODIGO N°	DESCRIPTION DESCRIPCION	6KFS	6KGS	REMARKS OBSERVACIONES
1	6CE-W8145-01	ROTOR ASSY WITH BOLTS ROTOR COMPLETO CON TORNILLO	1	1	
2	6EK-W9010-00	.BOLT SET .JUEGO DE TORNILLO	1	1	
3	6CE-81410-00	STATOR ASSY ESTATOR COMPLETO	1	1	
4	6CB-85580-00	COIL, PULSER BOBINA DE PULSACION	1	1	
5	6CB-85561-00	BASE, MAGNETO BASE DE MAGNETO	1	1	
6	99530-08012	.PIN, DOWEL .PASADOR, DE ESPIGA	2	2	
7	97595-05520	BOLT, WITH WASHER PERNO CON ARANDELA	2	2	
8	6CE-85592-00	STAY, PULSER SOPORTE, BOBINA DE PULSACION	1	1	
9	90465-11M10	CLAMP BRIDA	1	1	
10	95022-06035	BOLT, FLANGE PERNO, DE BRIDA	6	6	
11	95D95-06030	BOLT, FLANGE DEEP RECESS CERROJO, REBORDE HUECO PROFUND	4	4	
12	6CE-81337-01	COVER, FLYWHEEL CUBIERTA DE VOLANTE	1	1	
13	95D95-06025	BOLT, FLANGE DEEP RECESS CERROJO, REBORDE HUECO PROFUND	1	1	
14	90387-06285	COLLAR ESPACIADOR	1	1	
15	90480-15M31	GROMMET TAPON	1	1	
16	90480-12314	GROMMET TAPON	2	2	
17	6CB-85516-01	SPACER ESPACIADOR	2	2	
18	6CE-13437-61	MARK, CAUTION MARKER	1	1	EXCEPT FOR BRA EXCEPT FOR BRA
19	6EE-81994-40	LABEL, SAFETY ETIQUETA DE SEGURIDAD	1	1	EXCEPT FOR BRA
	6EE-81994-70	LABEL, SAFETY ETIQUETA DE SEGURIDAD	1	1	FOR BRA FOR BRA
20	6EE-81994-50	LABEL, SAFETY ETIQUETA DE SEGURIDAD	1	1	FOR CAR FOR CAR



6CL7100-Q180

FIG. 18 ELECTRICAL 1

EQUIPO ELECTRICO 1

REF. NO.	PART NO. CODIGO N°	DESCRIPTION DESCRIPCION	6KFS	6KGS	REMARKS OBSERVACIONES
1	6KA-8591A-01	ENGINE CONTROL UNIT ASSY UNIDAD CONTROL	1	1	EXCEPT FOR BRA EXCEPT FOR BRA FOR BRA FOR BRA
	6KA-8591A-10	ENGINE CONTROL UNIT ASSY UNIDAD CONTROL	1	1	
2	95D95-06020	BOLT, FLANGE DEEP RECESS CERROJO, REBORDE HUECO PROFUND	4	4	
3	6CB-82316-01	BRACKET, IGNITION COIL SOPORTE BOBINA ENCENDIDO	1	1	
4	64J-85516-01	SPACER ESPACIADOR	4	4	
5	69M-42758-01	COLLAR COLLAR	4	4	
6	90119-06293	BOLT, WITH WASHER TORNILLO CON ARANDELA	4	4	
7	6BR-81845-00	PLATE PLACA	1	1	
8	95D95-06012	BOLT, FLANGE DEEP RECESS CERROJO, REBORDE HUECO PROFUND	1	1	
9	90464-13249	CLAMP BRIDA	1	1	
10	90464-20181	CLAMP BRIDA	2	2	
11	6CE-81960-10	RECTIFIER & REGULATOR ASSY RECTIFICADOR Y REGULADOR	1	1	
12	6CE-81972-00-9S	COVER, RECTIFIER CUBIERTA DE RECTIFICADOR	1	1	
13	6CE-81975-00	PLATE, RECTIFIER FITTING PLACA ACCESORIA RECTIF.	1	1	
14	90119-06MA3	BOLT, WITH WASHER TORNILLO CON ARANDELA	6	6	
15	95D95-06025	BOLT, FLANGE DEEP RECESS CERROJO, REBORDE HUECO PROFUND	3	3	
16	6CE-1248A-00	PIPE 8 TUBO 8	1	1	
17	6CE-24377-00	PIPE, JOINT 2 TUBO DE UNION 2	2	2	
18	6CE-12483-00	PIPE 3 TUBO 3	1	1	
19	90445-107A5	HOSE (L30) TUBO (L30)	1	1	
20	90467-09M09	CLIP PRESILLA	1	1	
21	90462-06013	CLAMP BRIDA	1	1	
22	95023-06012	BOLT TORNILLO	1	1	
23	90464-26002	CLAMP BRIDA	1	1	
24	6CE-12481-10	PIPE 1 TUBO 1	1	1	
25	6CE-14872-00	PIPE 2 TUBO 2	1	1	
26	6CE-12485-00	PIPE 5 TUBO 5	1	1	

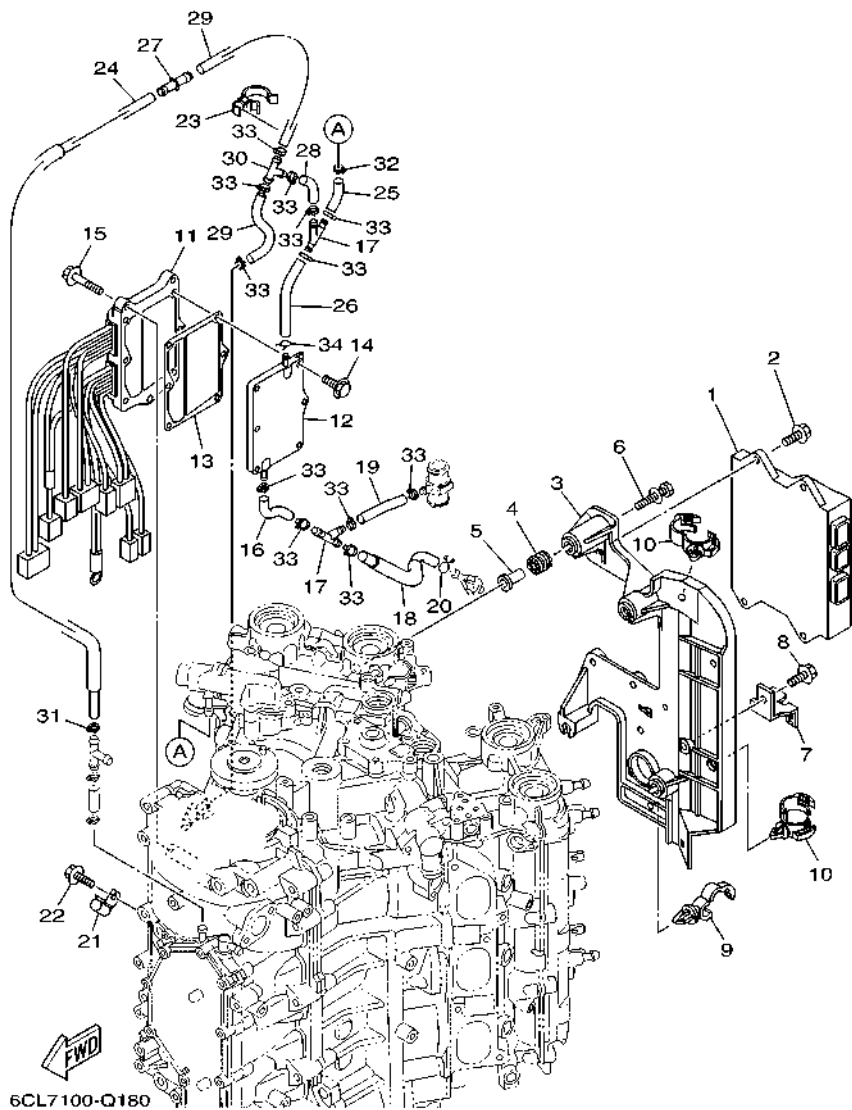

FIG. 18 ELECTRICAL 1

EQUIPO ELECTRICO 1

REF. NO.	PART NO. CODIGO N°	DESCRIPTION DESCRIPCION	6KFS	6KGS	REMARKS OBSERVACIONES
27	6CE-24376-01	PIPE, JOINT 1 TUBO DE UNION 1	1	1	
28	6CE-14872-00	PIPE 2 TUBO 2	1	1	
29	90445-09068	HOSE (L110) TUBO (L110)	2	2	
30	688-24378-00	PIPE, JOINT 3 TUBO DE UNION 3	1	1	
31	90465-11M10	CLAMP BRIDA	1	1	
32	90465-11M10	CLAMP BRIDA	1	1	
33	90465-11M10	CLAMP BRIDA	12	12	
34	90467-08004	CLIP PRESILLA	1	1	

FIG. 19 ELECTRICAL 2

EQUIPO ELECTRICO 2

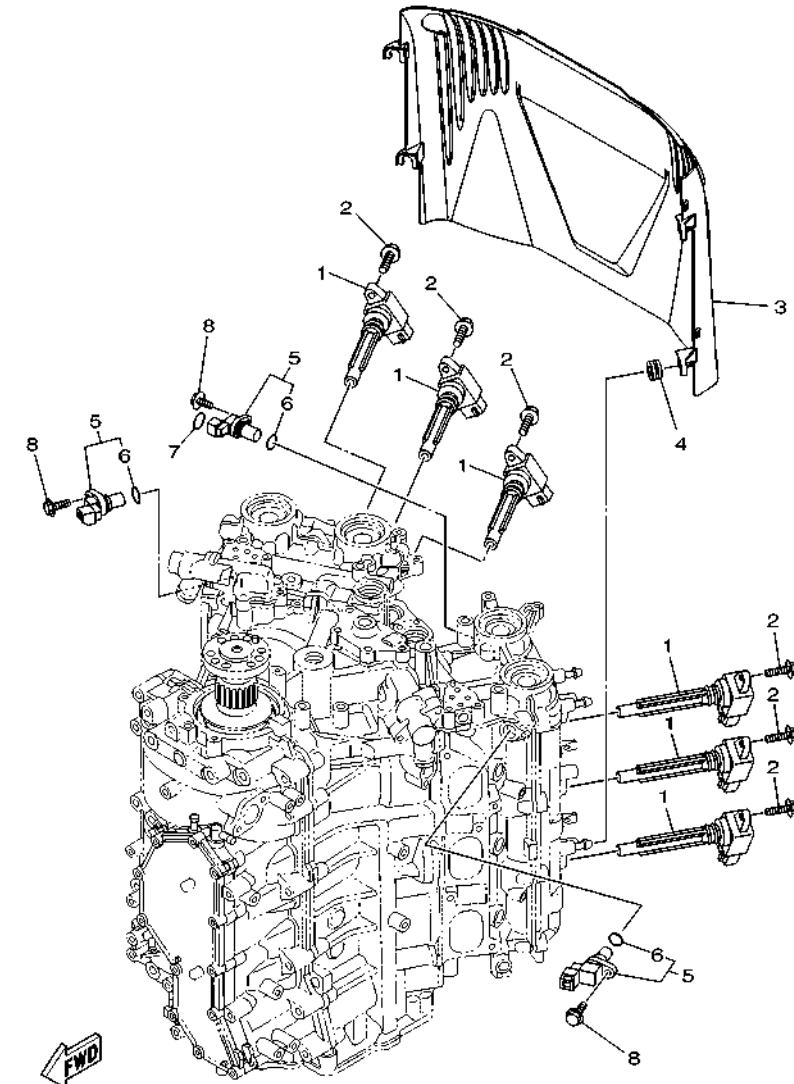

6KA1100-V200

REF. NO.	PART NO. CODIGO N°	DESCRIPTION DESCRIPCION	6KF3	6KG3	REMARKS OBSERVACIONES
1	6CB-82310-02	IGNITION COIL ASSY BOBINA DE ENCENDIDO COMPLETA	6	6	
2	95D95-06025	BOLT, FLANGE DEEP RECESS CERROJO, REBORDE HUECO PROFUND	6	6	
3	6CB-82314-00	COVER, IGNITION COIL CUBIERTA BOBINA ENCENDIDO	1	1	
4	90480-12314	GROMMET TAPON	4	4	
5	6P2-85896-00	SENSOR, CAM POSITION SENSOR DE LEVA	3	3	
6	6P2-85075-00	O-RING ANILLO-O	1	1	
7	93210-11001	O-RING ANILLO O	1	1	
8	97E95-06520	BOLT, HEXAGON W/W DEEP RECESS TORNILLO HEXAGONAL CON RONDONA	3	3	

FIG. 20 ELECTRICAL 3

EQUIPO ELECTRICO 3

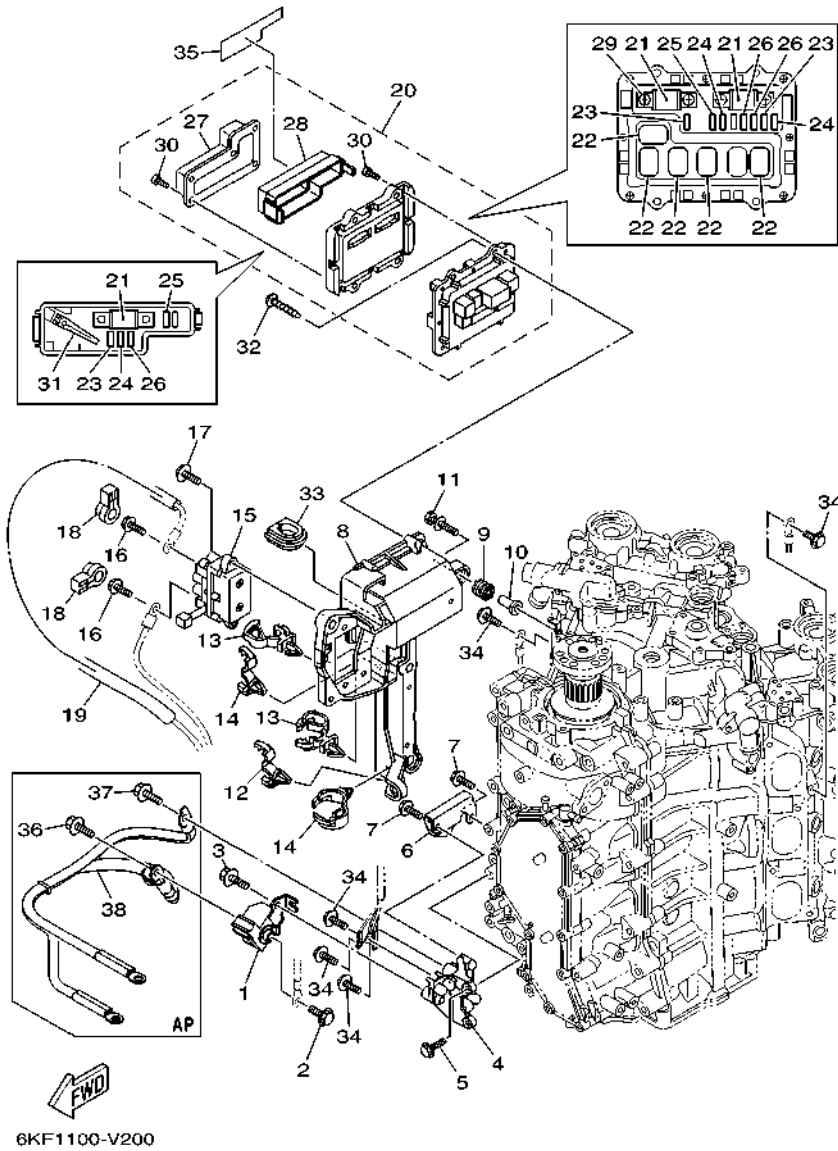

REF. NO.	PART NO. CODIGO N°	DESCRIPTION DESCRIPCION	6KF3	6KG3	REMARKS OBSERVACIONES
1	6KF-81925-00	TERMINAL TERMINAL	1	1	
2	95D95-08016	BOLT, FLANGE DEEP RECESS CERROJO, REBORDE HUECO PROFUND	1	1	
3	95814-08020	BOLT, FLANGE TORNILLO	1	1	
4	6KA-81929-00	BRACKET, TERMINAL SOPORTE	1	1	
5	95D95-06020	BOLT, FLANGE DEEP RECESS CERROJO, REBORDE HUECO PROFUND	2	2	
6	6KA-82588-00	PLATE PLACA	1	1	
7	95D95-06016	BOLT, FLANGE DEEP RECESS CERROJO, REBORDE HUECO PROFUND	2	2	
8	6CB-81948-02	BRACKET SOPORTE	1	1	
9	64J-85516-01	SPACER ESPACIADOR	5	5	
10	69M-42758-01	COLLAR COLLAR	5	5	
11	90119-06293	BOLT, WITH WASHER TORNILLO CON ARANDELA	5	5	
12	90464-13249	CLAMP BRIDA	1	1	
13	90464-12183	CLAMP BRIDA	2	2	
14	90464-20181	CLAMP BRIDA	2	2	
15	6AW-81950-00	RELAY ASSY RELE COMPLETO	1	1	
16	97E95-06610	BOLT, HEXAGON W/W DEEP RECESS TORNILLO HEXAGONAL CON RONDONA	2	2	
17	97513-06520	BOLT, WITH WASHER PERNO CON ARANDELA	2	2	
18	6P2-8183X-00	CAP, TERMINAL CUBIERTA DE TERMINAL	2	2	
19	90446-15003	HOSE (L100) TUBO (L100)	1	1	
20	6CE-82170-11	FUSE BOX ASSY CAJA DE FUSIBLES COMPL.	1	1	
21	6CE-82151-00	.FUSE (100A) .FUSIBLE (100A)	3	3	
22	6AW-8195A-00	.RELAY ASSY .RELE COMPLETO	5	5	
23	67F-82151-40	.FUSE (10A) .FUSIBLE (10A)	3	3	
24	67F-82151-50	.FUSE (15A) .FUSIBLE (15A)	3	3	
25	67F-82151-00	.FUSE (20A) .FUSIBLE (20A)	2	2	
26	67F-82151-10	.FUSE (30A) .FUSIBLE (30A)	3	3	
27	6CB-81639-10	.COVER .TAPA	1	1	

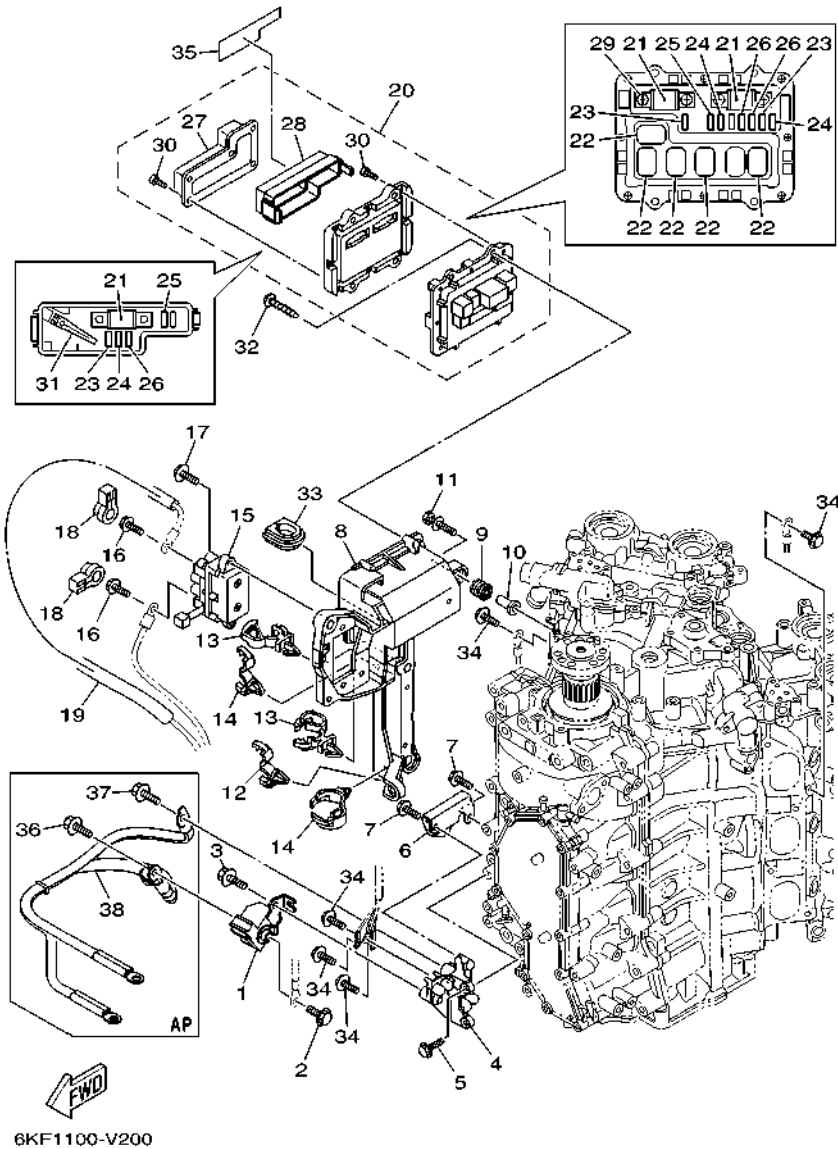

FIG. 20 ELECTRICAL 3

EQUIPO ELECTRICO 3

REF. NO.	PART NO. CODIGO N°	DESCRIPTION DESCRIPCION	6KF3	6KG3	REMARKS OBSERVACIONES
28	6CB-85544-00	.CASE .CAJA	1	1	
29	68F-82846-00	.SCREW, PAN HEAD (M5) .TORNILLO (M5)	4	4	
30	6P2-82113-00	.SCREW (M3) .TORNILLO (M3)	13	13	
31	67F-2812A-00	.PULLER, FUSE .TIRADOR DE FUSIBLE	1	1	
32	97780-50620	SCREW, TAPPING TORNILLO DE CABEZA DE CONO ACH	4	4	
33	6P2-81336-01	GROMMET TAPON PROTECTOR	1	1	
34	97E95-06516	BOLT, HEXAGON W/W DEEP RECESS TORNILLO HEXAGONAL CON RONDONA	5	5	
35	6CE-81919-21	GRAPHIC, REGULATOR CALCAMONIA DE REGULADOR	1	1	
36	97E95-08516	BOLT, HEXAGON W/W DEEP RECESS TORNILLO HEXAGONAL CON RONDONA	1	1	AP
37	97E95-08516	BOLT, HEXAGON W/W DEEP RECESS TORNILLO HEXAGONAL CON RONDONA	1	1	AP
38	6KA-82105-00	WIRE HARNESS ARNES DE CABLES	1	1	AP

FIG. 21 ELECTRICAL 4

EQUIPO ELECTRICO 4

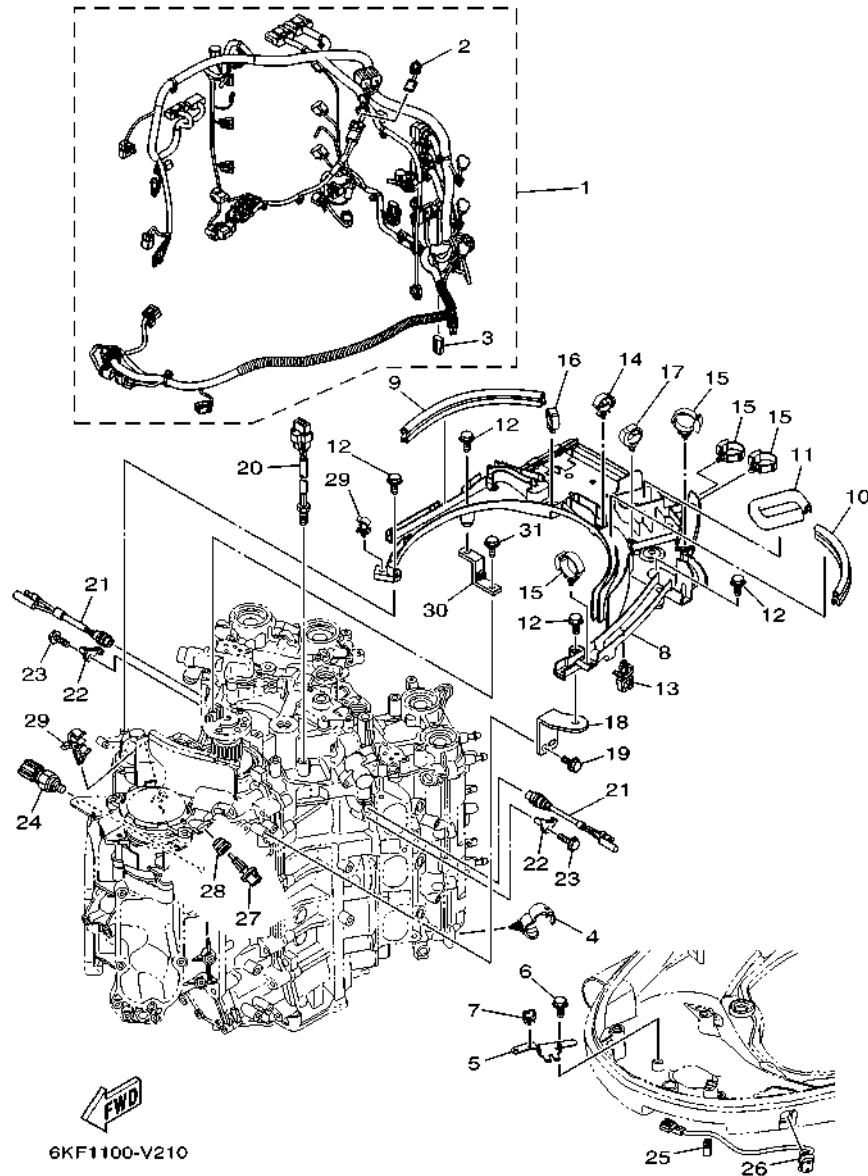

REF. NO.	PART NO. CODIGO N°	DESCRIPTION DESCRIPCION	6KF3	6KG3	REMARKS OBSERVACIONES
1	6KF-82590-01	WIRE HARNESS ASSY CONJUNTO DE CABLES	1	1	
2	6CE-81980-01	.DIODE ASSY .CONJUNTO DIODO	1	1	
3	68V-82582-10	.CAP 1 (2P) .TAPA 1 (2P)	1	1	
4	90464-20181	CLAMP BRIDA	4	4	
5	6KA-82594-00	CLAMP GRAMPA	1	1	
6	95D95-06012	BOLT, FLANGE DEEP RECESS CERROJO, REBORDE HUECO PROFUND	2	2	
7	90464-08004	CLAMP BRIDA	1	1	
8	6CB-82589-01	PROTECTOR, WIRE HARNESS PROTECTOR DE ARNES DE CABLE	1	1	
9	6BG-42617-00	DAMPER, FORM HULE DE FORMA	1	1	
10	6CB-42617-00	DAMPER, FORM HULE DE FORMA	1	1	
11	6CB-42629-00	SEAL SELLO 2	1	1	
12	95D95-06020	BOLT, FLANGE DEEP RECESS CERROJO, REBORDE HUECO PROFUND	5	5	
13	90464-11121	CLAMP BRIDA	1	1	
14	90464-18246	CLAMP BRIDA	1	1	
15	90464-12183	CLAMP BRIDA	4	4	
16	90464-20181	CLAMP BRIDA	1	1	
17	90464-20181	CLAMP BRIDA	1	1	
18	6CB-82388-00	PLATE PLACA	1	1	
19	95D95-06016	BOLT, FLANGE DEEP RECESS CERROJO, REBORDE HUECO PROFUND	2	2	
20	6CB-85790-00	THERMOSENSOR ASSY TERMICA SENSORIO	1	1	
21	6P2-82560-01	THERMO SWITCH ASSY INTER. DE TERMO	2	2	
22	6E9-82588-00	PLATE PLACA	2	2	
23	95D95-06012	BOLT, FLANGE DEEP RECESS CERROJO, REBORDE HUECO PROFUND	2	2	
24	6AW-83651-01	SENDER, OIL PRESSURE TRASMISOR DE PRESION DE ACEITE	1	1	
25	90464-16001	CLAMP BRIDA	1	1	
26	6GR-82563-00	TRIM & TILT SWITCH ASSY INTERRUPTOR DE INCLINACION	1	1	
27	63P-85886-00	SENSOR, AIR TEMPERATURE SENSOR	1	1	

FIG. 21 ELECTRICAL 4

EQUIPO ELECTRICO 4

REF. NO.	PART NO. CODIGO N°	DESCRIPTION DESCRIPCION	6KF3	6KG3	REMARKS OBSERVACIONES
28	6CE-14435-00	GROMMET ANILLO PROTECTOR	1	1	
29	90464-09129	CLAMP BRIDA	2	2	
30	6CB-81952-00	HOLDER, RELAY SOSTEN DE RELE	1	1	
31	95D95-06016	BOLT, FLANGE DEEP RECESS CERROJO, REBORDE HUECO PROFUND	1	1	

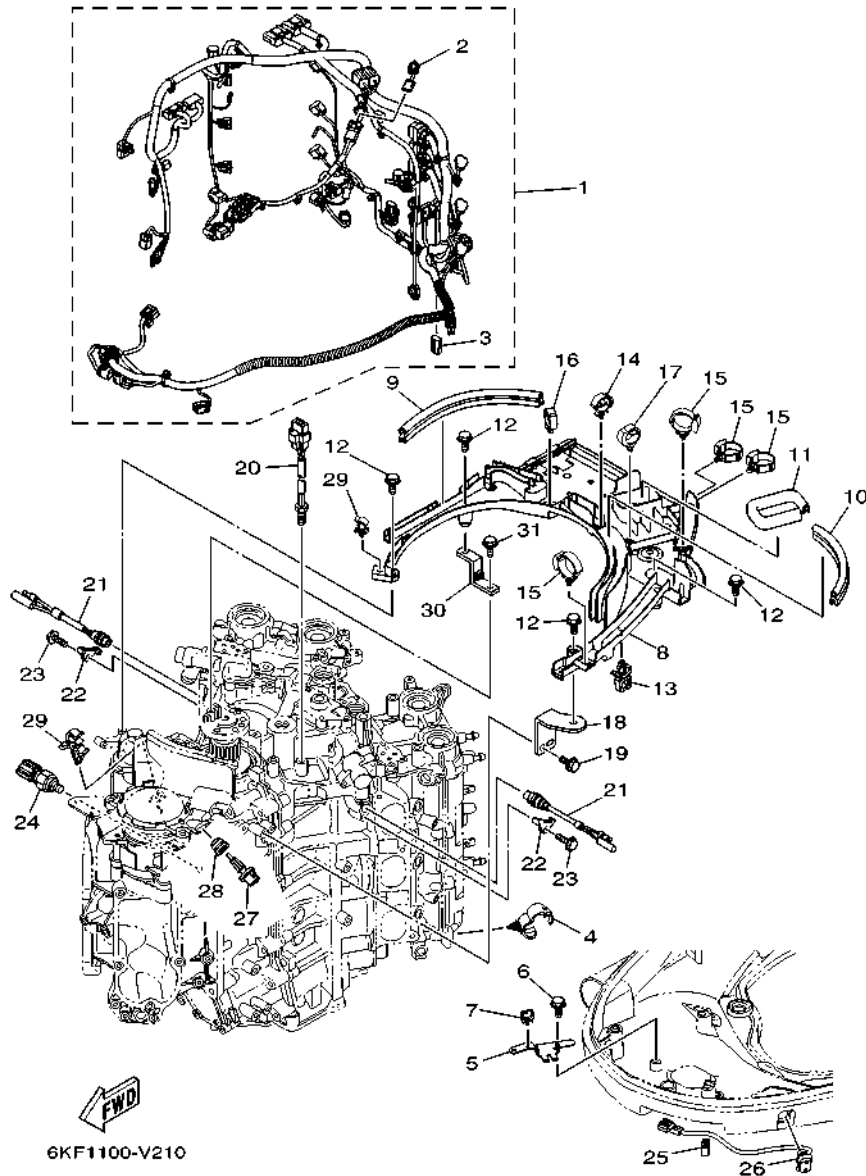

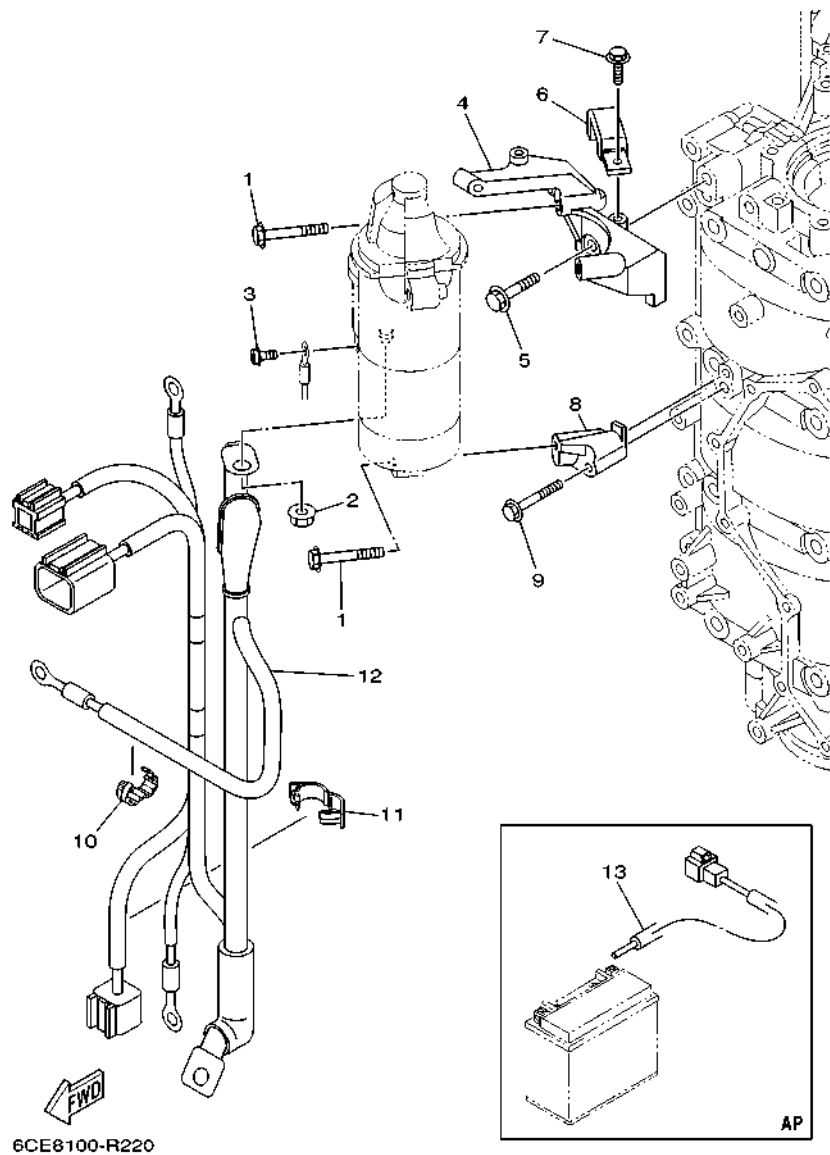
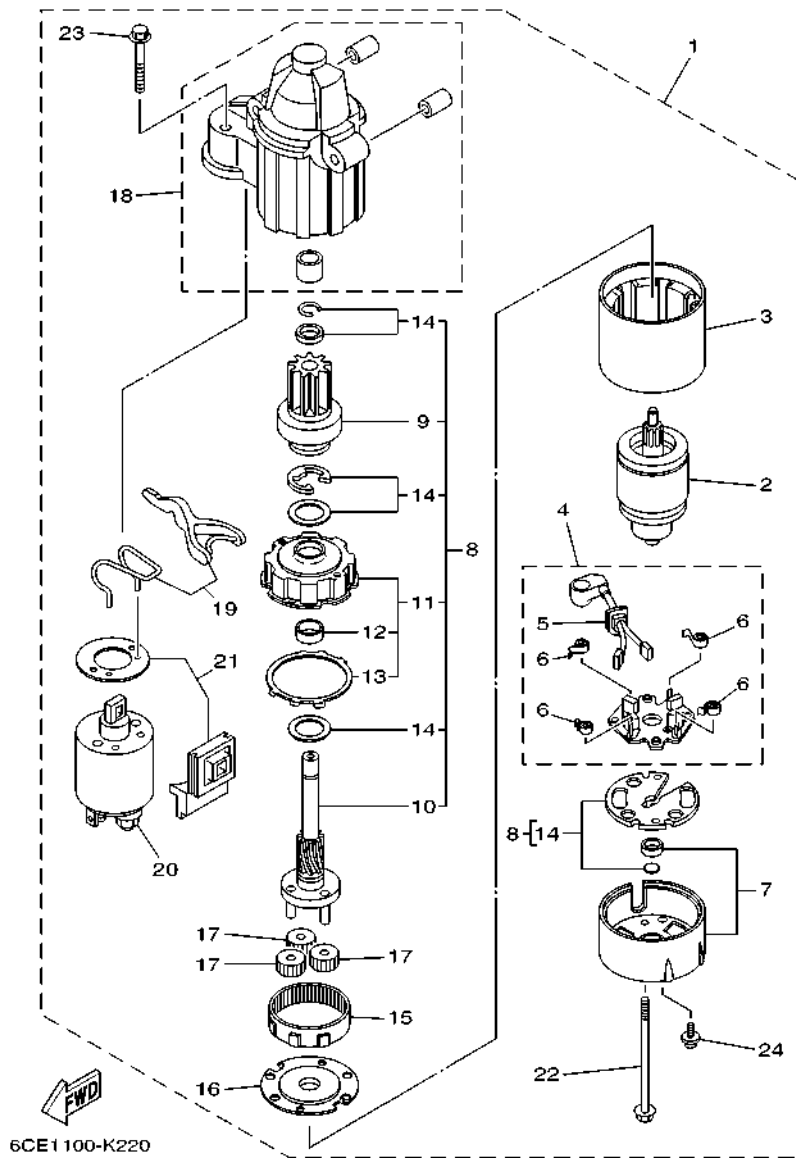

FIG. 22 ELECTRICAL 5

EQUIPO ELECTRICO 5

REF. NO.	PART NO. CODIGO N°	DESCRIPTION DESCRIPCION	6KFS	6KGS		REMARKS OBSERVACIONES
1	97513-08545	BOLT, WITH WASHER PERNO CON ARANDELA	3	3		
2	90179-08003	NUT TUERCA	1	1		
3	97985-04308	SCREW, WITH WASHER TORNILLO, CON ARANDELA	1	1		
4	6CB-81822-02	BRACKET, STARTING MOTOR SOPORTE DE MOTOR DE ARRANQUE	1	1		
5	90105-08M87	BOLT, FLANGE TORNILLO	2	2		
6	6CB-81443-00	CLAMP, LEAD 1 GRAMPA DE CABLE 1	1	1		
7	95D95-06016	BOLT, FLANGE DEEP RECESS CERROJO, REBORDE HUECO PROFUND	1	1		
8	6CB-81823-A0	STAY, STARTING MOTOR SUPORTE	1	1		
9	90105-06151	BOLT, FLANGE TORNILLO	1	1		
10	90464-13227	CLAMP BRIDA	1	1		
11	90464-18004	CLAMP BRIDA	1	1		
12	6CE-8259M-00	WIRE HARNESS ASSY 2 ARNES DE CABLES	1	1		
13	6KW-81949-00	WIRE, LEAD (ISOLATOR, 3.8M) CABLE CONDUCTOR, 3.8M	1	1		AP AP



6CE1100-K220

FIG. 23 STARTING MOTOR

MOTOR DE ARRANQUE

REF. NO.	PART NO. CODIGO N°	DESCRIPTION DESCRIPCION	6KFS	6KGS	REMARKS OBSERVACIONES
1	6CE-81800-02	STARTING MOTOR ASSY MOTOR DE ARRANQUE COMPLETO	1	1	
2	6CE-81850-00	.ARMATURE ASSY .INDUCIDO COMPLETO	1	1	
3	6CE-81810-00	.STATOR ASSY .ESTATOR COMPLETO	1	1	
4	6CE-81840-01	.BRUSH HOLDER ASSY .SOSTEN DE ESCOBILLA COMPLETO	1	1	
5	6CE-81801-01	.BRUSH SET .JUEGO DE ESCOBILLA	1	1	
6	67F-81813-00	.SPRING, BRUSH .RESORTE DE ESCOBILLA	4	4	
7	6CE-81820-00	.REAR BRACKET ASSY .CUBIERTA TRASERA COMPL	1	1	
8	6CE-81807-00	.GEAR ASSY, STARTING MOTOR .PINON CONJUNTO	1	1	
9	6CB-81832-00	.CLUTCH, OVER RUN .PINON COMPL	1	1	
10	6CB-81836-00	.SHAFT, PINION .ARBOL, PINON	1	1	
11	6CE-81821-00	.BRACKET, CENTER 1 .SOPORTE, CENTRO 1	1	1	
12	67F-81841-00	...BEARING ...PORTADOR	1	1	
13	67F-8183R-00	...GASKET ...EMPAQUETADURA	1	1	
14	6CB-81809-00	.WASHER KIT .JUEGO DE ARANDELA	1	1	
15	67F-81891-00	.GEAR, RING .ENGRANAJE ANILLO	1	1	WITH 67F-8183R-00 WITH 67F-8183R-00
16	6CE-81830-00	.BRACKET, CENTER 2 .SOPORTE, CENTRO 2	1	1	
17	60V-8183T-00	.GEAR, IDLER .ENGRANAJE NEUTRO	3	3	
18	6CE-81842-00	.COVER .TAPA	1	1	
19	6CE-81839-00	.LEVER ASSY .PALANCA COMPL.	1	1	
20	6C5-81941-01	.STARTER RELAY ASSY .RELE DE ARRANQUE	1	1	
21	6CE-81869-00	.COVER, DUST .CUBIERTA PARA POLVO	1	1	
22	6CB-81826-00	.BOLT .PERNO	2	2	
23	69J-81828-00	.BOLT 2 .TORNILLO DE EMPUJE 2	2	2	
24	67F-81846-00	.SCREW .TORNILLO	2	2	

FIG. 24 BOTTOM COWLING 1

CUBIERTA INFERIOR 1

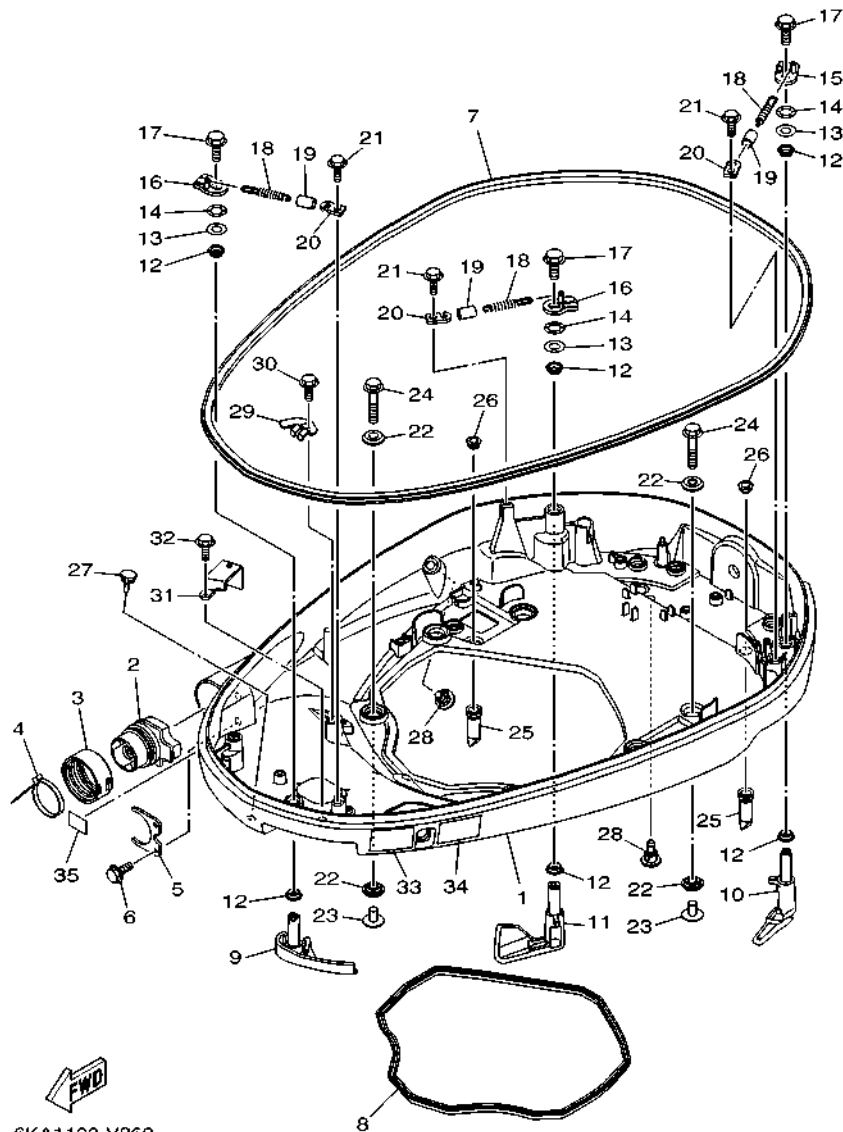

6KA1100-V260

REF. NO.	PART NO. CODIGO N°	DESCRIPTION DESCRIPCION	6KFS	6KGS	REMARKS OBSERVACIONES
1	6KA-42710-00-8D	BOTTOM COWLING ASSY CUBIERTA INFERIOR COMPL.	1	1	UR GRAY
	6KA-42710-00-CE	BOTTOM COWLING ASSY CUBIERTA INFERIOR COMPL.	1	1	UR GRAY UR WHITE UR WHITE
2	6KA-42725-01	GROMMET TAPON	1	1	
3	68F-42753-00	FASTNER TIRADOR	1	1	AP AP
4	90464-20258	CLAMP BRIDA	1	1	AP AP
5	6CB-42761-00	STOPPER RETEN 1	1	1	
6	95D95-06014	BOLT, FLANGE DEEP RECESS CERROJO, REBORDE HUECO PROFUND	2	2	
7	6KA-42615-00	SEAL SELLO	1	1	
8	6CB-42716-01	RUBBER SEAL 1 SELLO DE GOMA 1	1	1	
9	6KA-42815-00-8D	LEVER, CLAMP 1 PALANCA ABRAZADERA 1	1	1	UR GRAY UR GRAY
	6KA-42815-00-CE	LEVER, CLAMP 1 PALANCA ABRAZADERA 1	1	1	UR WHITE UR WHITE
10	6KA-42816-00-8D	LEVER, CLAMP 2 PALANCA ABRAZADERA 2	1	1	UR GRAY UR GRAY
	6KA-42816-00-CE	LEVER, CLAMP 2 PALANCA ABRAZADERA 2	1	1	UR WHITE UR WHITE
11	6KA-42817-00-8D	LEVER, CLAMP 3 PALANCA ABRAZADERA 3	1	1	UR GRAY UR GRAY
	6KA-42817-00-CE	LEVER, CLAMP 3 PALANCA ABRAZADERA 3	1	1	UR WHITE UR WHITE
12	90386-15M73	BUSH BUJE	6	6	
13	90201-156J2	WASHER, PLATE ARANDELA PLANA	3	3	
14	90206-15M18	WASHER, WAVE ARANDELA ONDULADA	3	3	
15	6CB-42818-00	LEVER, CLAMP 4 PALANCA, ABRAZADERA 4	1	1	
16	6CB-42819-00	LEVER, CLAMP 5 PALANCA ABRAZADERA 5	2	2	
17	95D95-08012	BOLT, FLANGE DEEP RECESS CERROJO, REBORDE HUECO PROFUND	3	3	
18	90506-22001	SPRING, TENSION RESORTE DE TENSION	3	3	
19	90445-15M03	HOSE (L23) TUBO (L23)	3	3	
20	66T-43144-00	HOOK, SPRING GANCHO	3	3	
21	95D95-06012	BOLT, FLANGE DEEP RECESS CERROJO, REBORDE HUECO PROFUND	3	3	
22	90480-22M81	GROMMET TAPON	12	12	
23	90387-08M37	COLLAR ESPACIADOR	6	6	

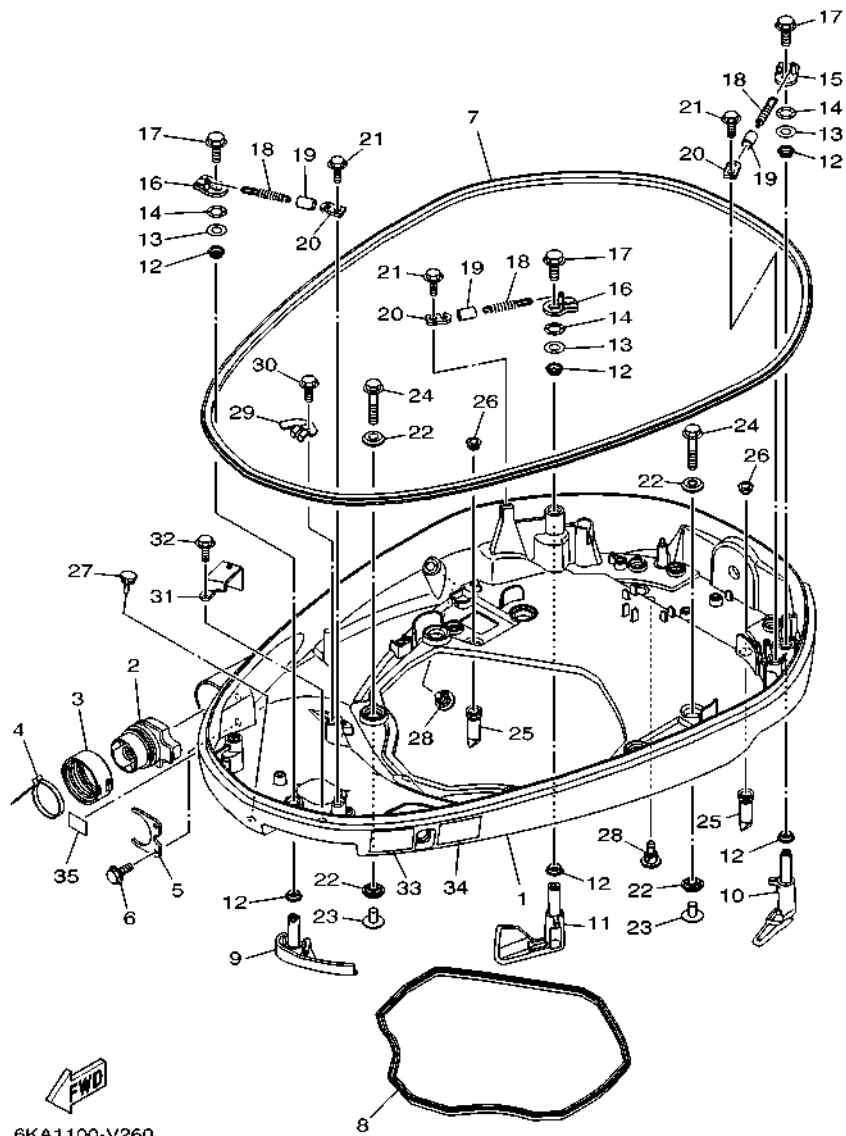

FIG. 24 BOTTOM COWLING 1

CUBIERTA INFERIOR 1

REF. NO.	PART NO. CODIGO N°	DESCRIPTION DESCRIPCION	6KFS	6KGS	REMARKS OBSERVACIONES
24	90119-08187	BOLT, WITH WASHER TORNILLO CON ARANDELA	6	6	
25	6DA-42717-01	RUBBER, SEAL 2 GOMA	4	4	
26	6DA-42384-00	SEAL, CAP SELLO DE TAPA	4	4	
27	6H4-42748-01	GROMMET TAPON	1	1	
28	6P2-44391-00	NIPPLE, HOSE NIPLE MANGUERA	2	2	
29	6KA-42766-00	BRACKET 2 SOPORTE 2	1	1	
30	95D95-06012	BOLT, FLANGE DEEP RECESS CERROJO, REBORDE HUECO PROFUND	1	1	
31	6CB-42756-00	STAY, CLAMP SOPORTE DE GRAMPA	1	1	
32	95D95-06012	BOLT, FLANGE DEEP RECESS CERROJO, REBORDE HUECO PROFUND	1	1	
33	6EE-42794-40	LABEL, WARNING (GENERAL) ETIQUETA DE PRECAUCION	1	1	EXCEPT FOR BRA EXCEPT FOR BRA
	6EE-42794-70	LABEL, WARNING (GENERAL) ETIQUETA DE PRECAUCION	1	1	FOR BRA FOR BRA
34	6EE-42794-50	LABEL, WARNING (GENERAL) ETIQUETA DE PRECAUCION	1	1	FOR CAR FOR CAR
35	6AH-81996-00	MARK MARCA	1	1	FOR CAR FOR CAR

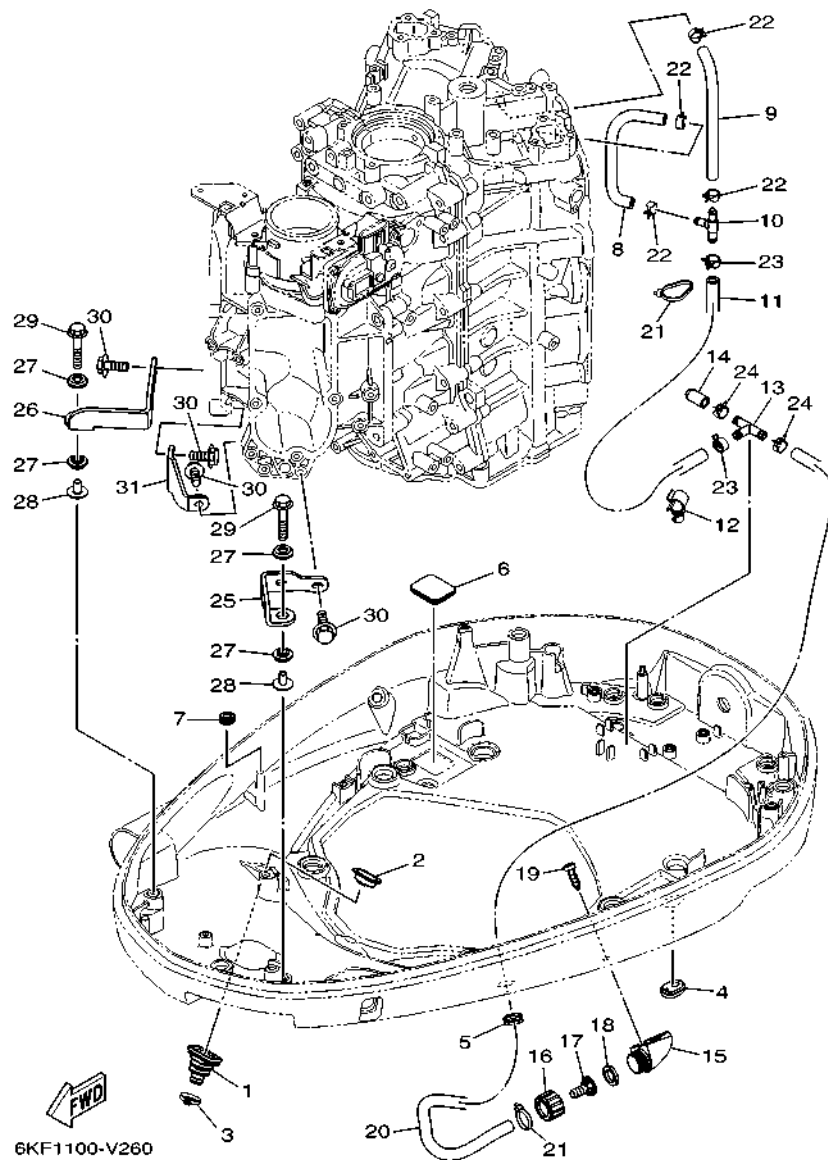

FIG. 25 BOTTOM COWLING 2

CUBIERTA INFERIOR 2

REF. NO.	PART NO. CODIGO N°	DESCRIPTION DESCRIPCION	6KF3	6KG3		REMARKS OBSERVACIONES
1	6BG-42724-01	GROMMET TAPON	1	1		
2	6BG-42384-00	SEAL, CAP SELLO DE TAPA	1	1		
3	90465-11M10	CLAMP BRIDA	1	1		
4	6KA-42727-00	GROMMET TAPON	1	1		
5	90480-19031	GROMMET TAPON	1	1		
6	6KF-43885-00	GROMMET ARANDELA DE REFUERZO	1	1		
7	90480-13163	GROMMET TAPON	1	1		
8	6CB-24315-00	PIPE 5 TUBO DE DESAGUE	1	1		
9	90445-14021	HOSE (L185) TUBO (L185)	1	1		
10	6AW-42169-00	JOINT CONECTOR	1	1		
11	6KA-13582-00	PIPE TUBO	1	1		
12	90464-16017	CLAMP BRIDA	1	1		
13	90413-10001	WAY 3 UNION	1	1		
14	6KA-13587-00	CAP, JOINT TAPA DE TOBERA	1	1		
15	6AW-12572-00	ADAPTER ADAPTADOR	1	1		
16	6R3-12581-00	JOINT, HOSE 1 CONEXION	1	1		
17	6AW-12582-00	JOINT, HOSE 2 CONEXION	1	1		
18	6R3-12583-00	GASKET, HOSE JOINT EMPAQUETADURA JUNTA DE MANGUE	1	1		
19	97780-60520	SCREW, TAPPING TORNILLO DE CABEZA DE CONO ACH	2	2		
20	6KA-42541-00	PIPE 1 TUBO 1	1	1		
21	90465-11M10	CLAMP BRIDA	2	2		
22	90467-130A5	CLIP PRESILLA	4	4		
23	90467-140A8	CLIP PRESILLA	2	2		
24	90467-140A9	CLIP PRESILLA	2	2		
25	6CB-42643-00	PLATE, CLAMP PLACA GRAMPA	1	1		
26	6CB-42644-00	PLATE, CLAMP 2 PLACA GRAMPA 2	1	1		
27	90480-14029	GROMMET TAPON	4	4		

FIG. 25 BOTTOM COWLING 2

CUBIERTA INFERIOR 2

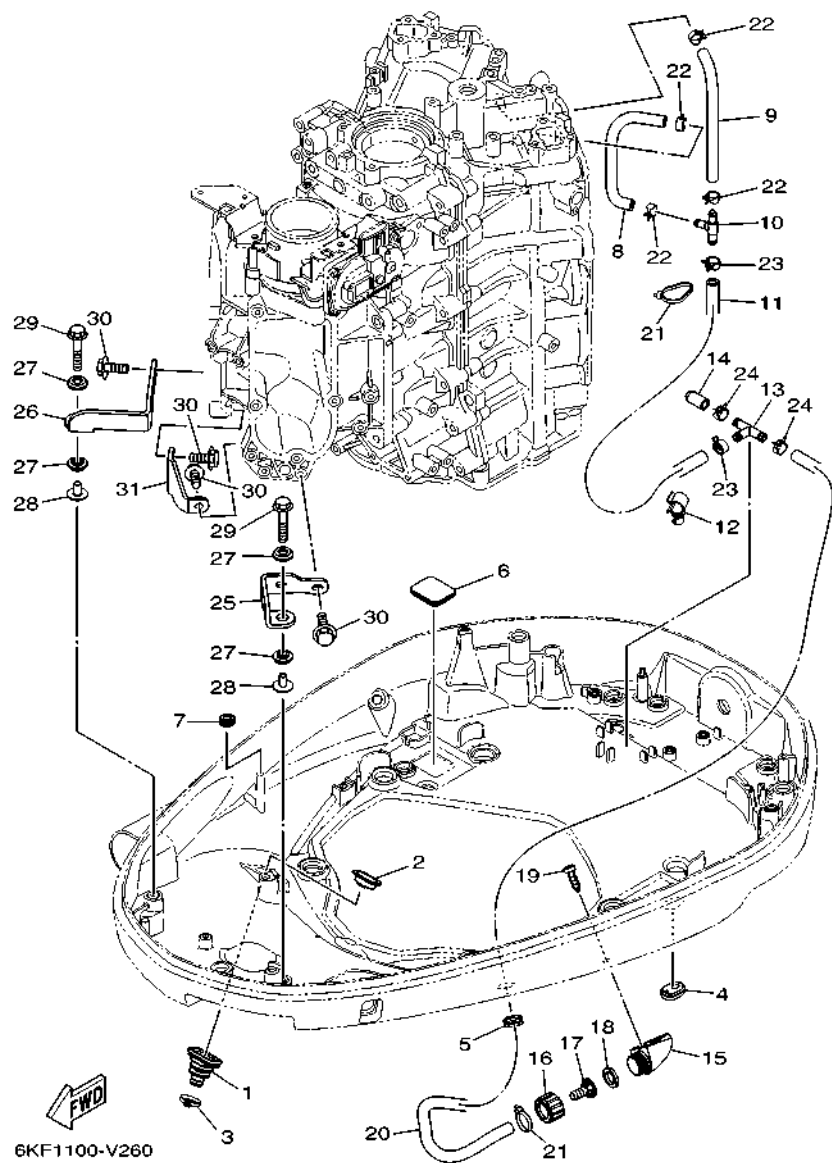

REF. NO.	PART NO. CODIGO N°	DESCRIPTION DESCRIPCION	6KF3	6KG3			REMARKS OBSERVACIONES
28	90387-06M03	COLLAR ESPACIADOR	2	2			
29	90119-06291	BOLT, WITH WASHER TORNILLO CON ARANDELA	2	2			
30	90105-06039	BOLT, FLANGE TORNILLO	6	6			
31	6CB-42744-00	STAY SOPORTE	1	1			
<hr/>							
<hr/>							
<hr/>							
<hr/>							
<hr/>							
<hr/>							
<hr/>							
<hr/>							
<hr/>							
<hr/>							

FIG. 26 BOTTOM COWLING 3

CUBIERTA INFERIOR 3

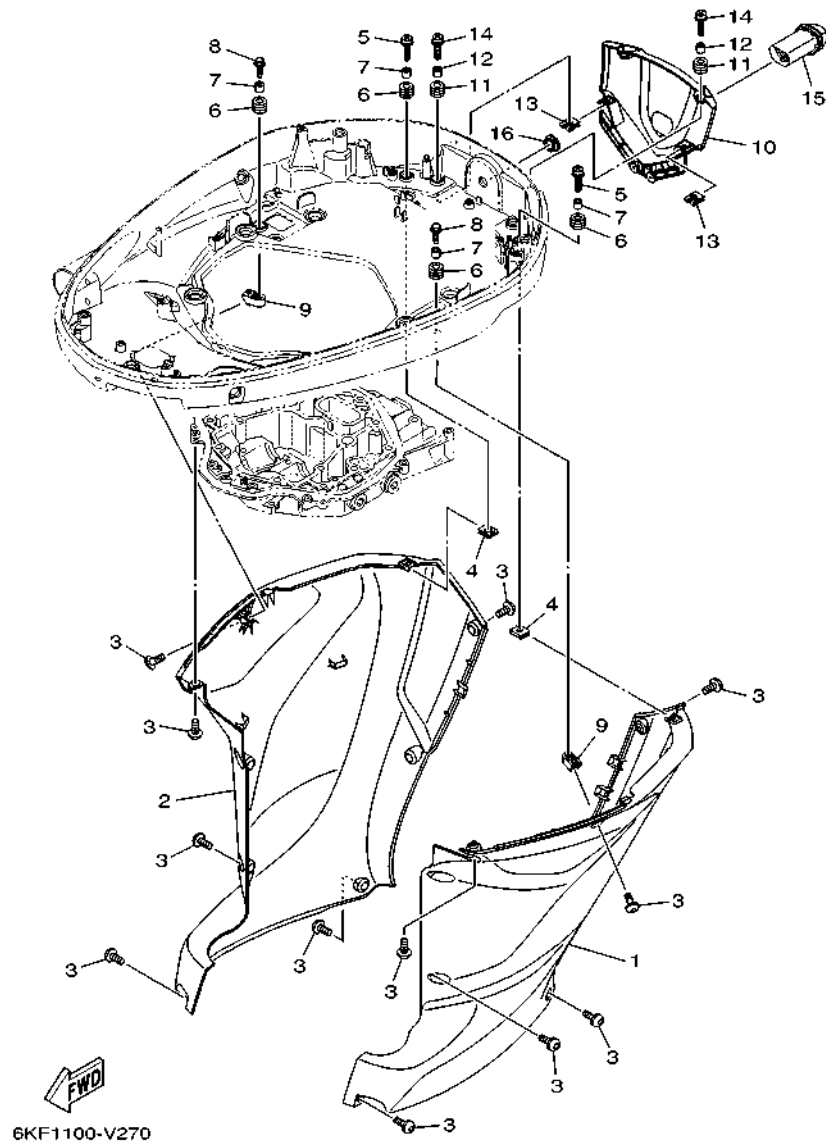

REF. NO.	PART NO. CODIGO N°	DESCRIPTION DESCRIPCION	6KF3	6KG3	REMARKS OBSERVACIONES
1	6KF-42740-00-8D	APRON COMPLETE 1 MANDIL COMPLETO 1	1	1	UR GRAY
	6KF-42740-00-CE	APRON COMPLETE 1 MANDIL COMPLETO 1	1	1	UR WHITE
2	6KF-42770-00-8D	APRON COMPLETE 2 MANDIL COMPLETO 2	1	1	UR GRAY
	6KF-42770-00-CE	APRON COMPLETE 2 MANDIL COMPLETO 2	1	1	UR WHITE
3	90111-06144	BOLT, HEXAGON SOCKET BUTTON TORNILLO	16	16	
4	90183-061A8	NUT, SPRING TUERCA DE RESORTE	2	2	
5	90159-06053	SCREW, WITH WASHER TORNILLO CON VALONA	2	2	
6	90480-13M24	GROMMET TAPON	4	4	
7	90387-06M43	COLLAR ESPACIADOR	4	4	
8	90109-06M80	BOLT PERNO	2	2	
9	6CE-42774-A0	STAY, APRON 1 BUJEDEL PIVOTE DE LA FLECHA	2	2	
10	6KA-42723-00-8D	COVER, BOTTOM CUBIERTA INFERIOR	1	1	UR GRAY
	6KA-42723-00-CE	COVER, BOTTOM CUBIERTA INFERIOR	1	1	UR WHITE
11	90480-13M24	GROMMET TAPON	4	4	UR WHITE
12	90387-06M43	COLLAR ESPACIADOR	4	4	
13	90183-061A8	NUT, SPRING TUERCA DE RESORTE	2	2	
14	90159-06053	SCREW, WITH WASHER TORNILLO CON VALONA	4	4	
15	6KA-42769-00	SEAL, RUBBER SELLO DE GOMA	1	1	
16	676-42726-00	GROMMET TAPON	1	1	

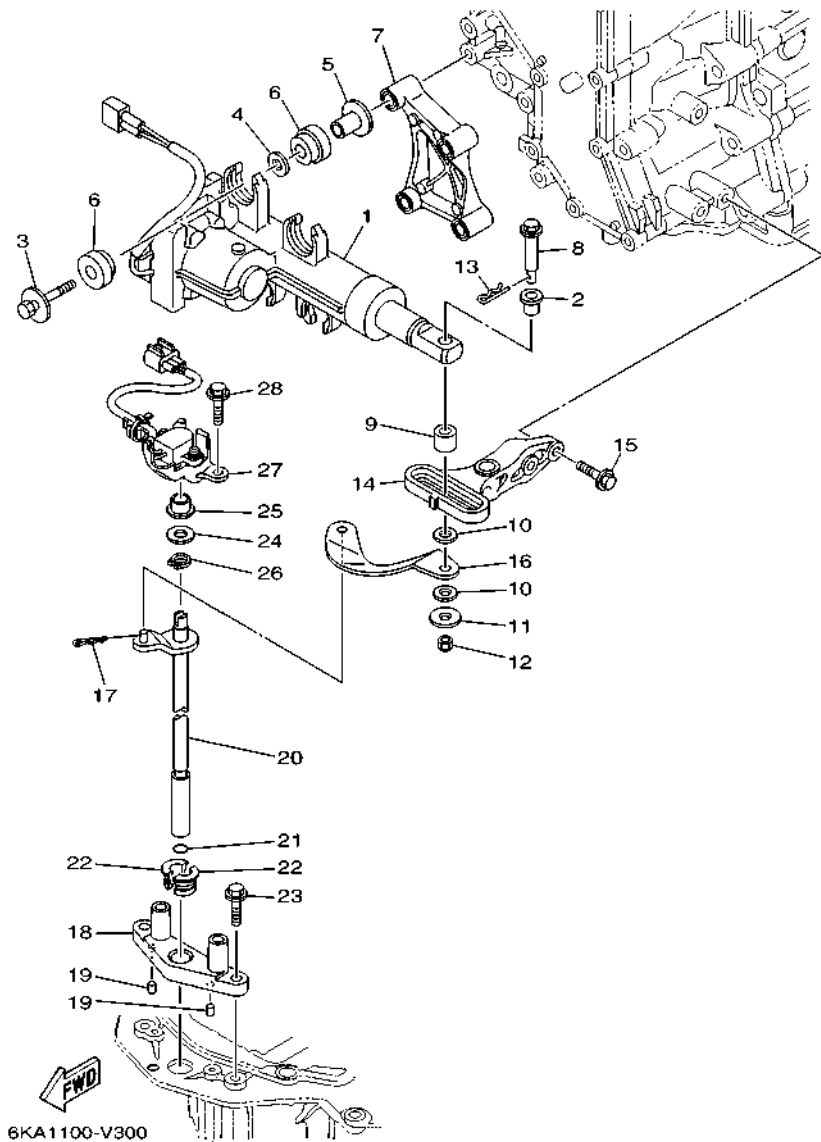

FIG. 27 CONTROL

CONTROL

REF. NO.	PART NO. CODIGO N°	DESCRIPTION DESCRIPCION	6KFS	6KGS	REMARKS OBSERVACIONES
1	6DV-4820A-01	ACTUATOR UNIT UNIDAD DE ACTUADOR	1	1	
2	90386-08008	BUSH BUJE	1	1	
3	90119-08168	BOLT, WITH WASHER TORNILLO CON ARANDELA	4	4	
4	90201-12064	WASHER, PLATE ARANDELA PLANA	4	4	
5	90387-08104	COLLAR ESPACIADOR	4	4	
6	6CE-85564-00	GROMMET ANILLO PROTECTOR	8	8	
7	6CE-44142-20	JOINT CONECTOR	1	1	
8	6CE-42195-10	PIN, JOINT 1 PASADOR DE CONECTOR	1	1	
9	6CE-44122-20	BUSHING, SHIFT ROD LEVER BUJE PALANCA VARILLA DE CAMBIO	1	1	
10	90202-08M41	WASHER, PLATE ARANDELA DE PLANA	2	2	
11	90201-06068	WASHER, PLATE ARANDELA PLANA	1	1	
12	90185-06M07	NUT, SELF-LOCKING TUERCA AUTOBLOCANTE	1	1	
13	90468-18008	CLIP PRESILLA	1	1	
14	6CE-44117-10	BRACKET SOPORTE	1	1	
15	97E75-06525	BOLT, HEXAGON W/W DEEP RECESS TORNILLO HEXAGONAL CON RONDONA	2	2	
16	6CE-44121-10	LEVER, SHIFT ROD PALANCA VARILLA CAMBIOS	1	1	
17	90468-18008	CLIP PRESILLA	1	1	
18	6CE-44118-A0	BRACKET SOPORTE	1	1	
19	93604-07M13	PIN, DOWEL PASADOR DE CLAVIJA	2	2	
20	6JD-44120-01	HANDLE GEAR SHIFT ASSY MANIJA DE CAMBIO COMPL	1	1	
21	93210-09165	O-RING ANILLO O	1	1	
22	90386-11001	BUSH BUJE	2	2	
23	95D75-06025	BOLT, FLANGE DEEP RECESS CERROJO, REBORDE HUECO PROFUND	2	2	
24	90201-11008	WASHER, PLATE ARANDELA PLANA	1	1	
25	90386-10001	BUSH BUJE	1	1	
26	93410-10082	CIRCLIP SEGURO	1	1	
27	6CE-68303-00	SENSOR ASSY SENSOR COMP.	1	1	

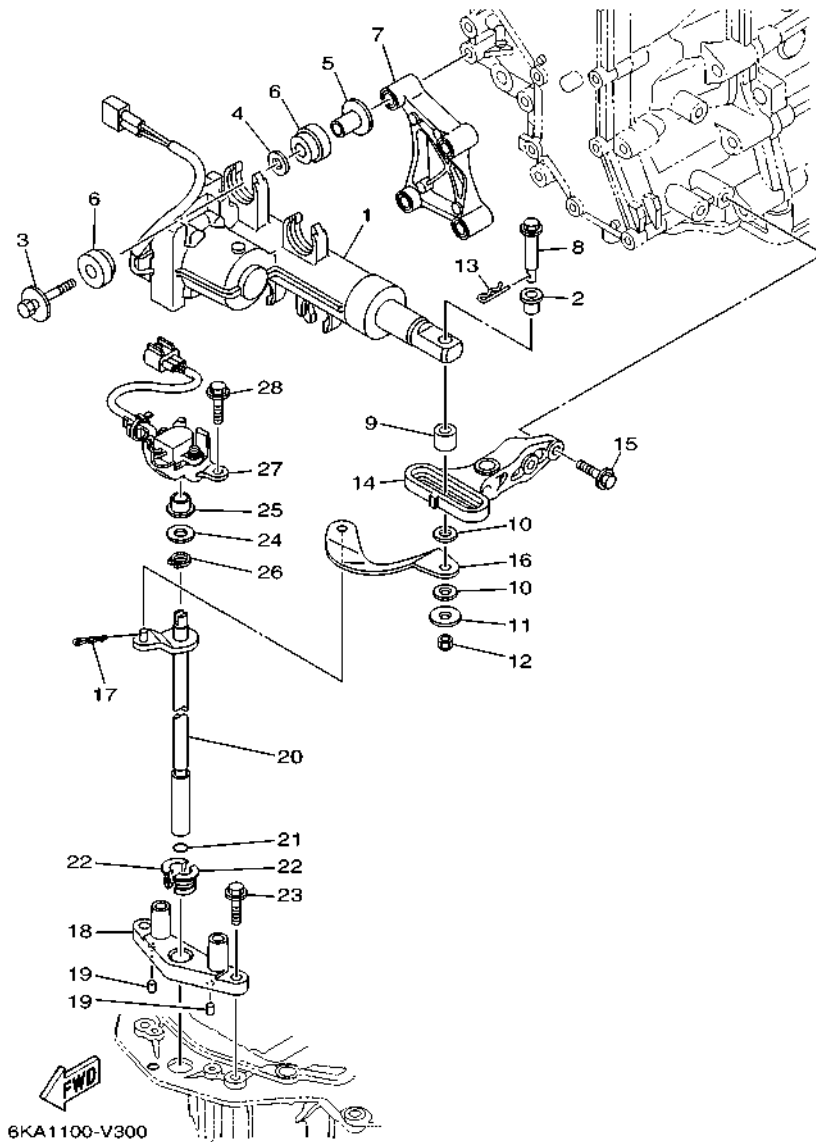

FIG. 27 CONTROL

CONTROL

REF. NO.	PART NO. CODIGO N°	DESCRIPTION DESCRIPCION	6KFS	6KGS	REMARKS OBSERVACIONES
28	95D75-06025	BOLT, FLANGE DEEP RECESS CERROJO, REBORDE HUECO PROFUND	2	2	
<hr/>					
<hr/>					
<hr/>					
<hr/>					
<hr/>					
<hr/>					
<hr/>					

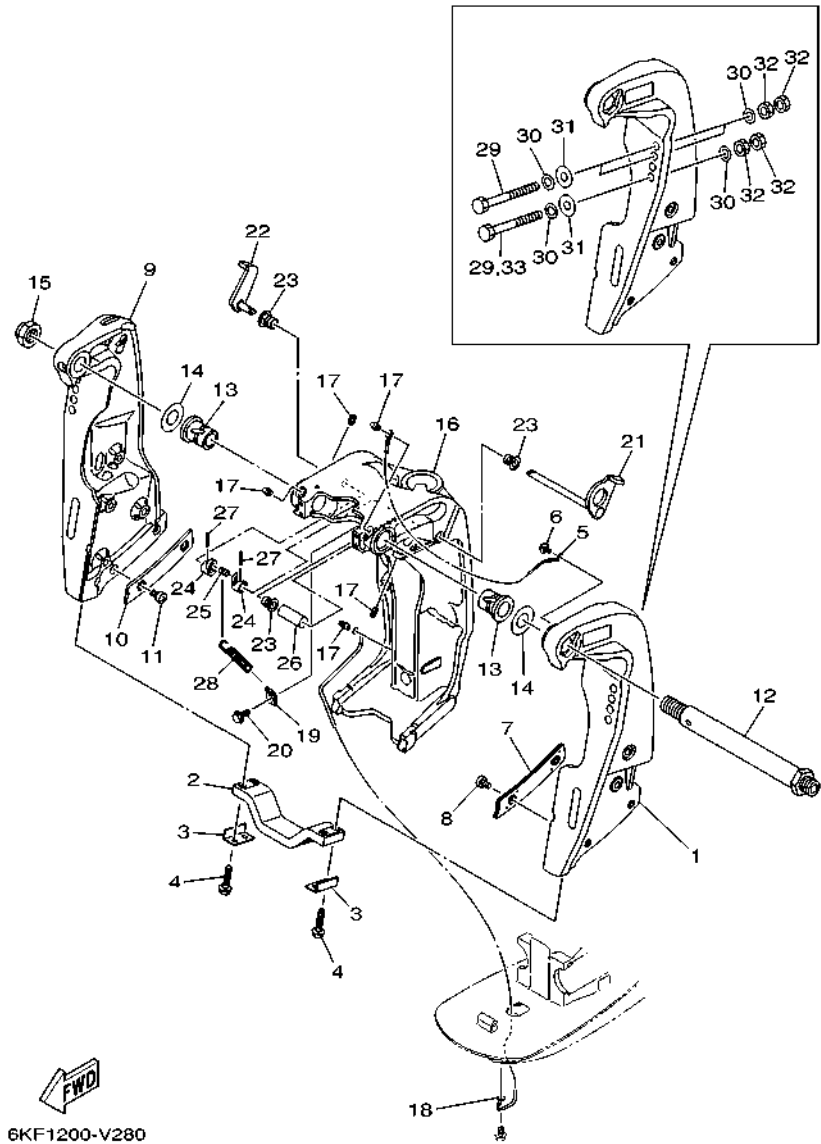
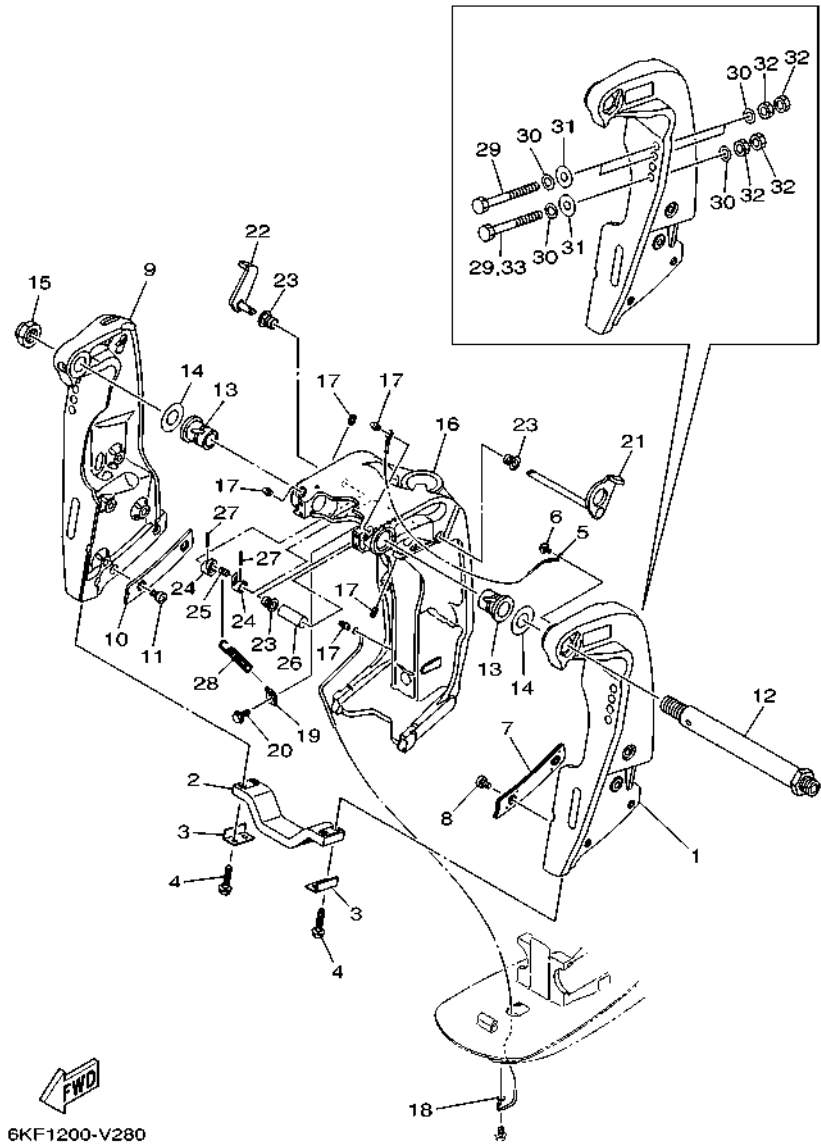

FIG. 28 BRACKET 1

SOPORTE 1

REF. NO.	PART NO. CODIGO N°	DESCRIPTION DESCRIPCION	6KFS	6KG3	REMARKS OBSERVACIONES
1	69J-43111-03-8D	BRACKET, CLAMP 1 SOPORTE DE LA ABRAZADERA 1	1	1	UR GRAY
	69J-43111-03-CE	BRACKET, CLAMP 1 SOPORTE DE LA ABRAZADERA 1	1	1	UR GRAY UR WHITE UR WHITE
2	6G5-45251-02	ANODE CATODE	1	1	
3	6G5-44526-00	PLATE PLACA 1	2	2	
4	97E95-06525	BOLT, HEXAGON W/W DEEP RECESS TORNILLO HEXAGONAL CON RONDONA	4	4	
5	6E5-82148-00	WIRE, LEAD 4 CABLE CONDUCTOR 4	1	1	
6	97985-06212	SCREW, WITH WASHER TORNILLO, CON ARANDELA	1	1	
7	61A-43132-01	WASHER, FRICTION ARANDELA DE FRICCION	1	1	
8	97885-06010	SCREW, PAN HEAD TORNILLO A MUESCA	2	2	
9	69J-43112-03-8D	BRACKET, CLAMP 2 SOPORTE DE LA ABRAZADERA 2	1	1	UR GRAY UR GRAY
	69J-43112-03-CE	BRACKET, CLAMP 2 SOPORTE DE LA ABRAZADERA 2	1	1	UR WHITE UR WHITE
10	61A-43133-01	WASHER, FRICTION RONDANA	1	1	
11	97885-06010	SCREW, PAN HEAD TORNILLO A MUESCA	2	2	
12	6R3-43131-00	BOLT, CLAMP BRACKET TORNILLO DE ABRAZADERA DEL SOP	1	1	
13	90386-25M31	BUSH BUJE	2	2	
14	90201-26M59	WASHER, PLATE ARANDELA PLANA	2	2	
15	90185-22M11	NUT, SELF-LOCKING TUERCA AUTOBLOCANTE	1	1	
16	6KF-43311-00-8D	BRACKET, SWIVEL 1 SOPORTE GIRATORIO 1	1	1	UR GRAY UR GRAY
	6KF-43311-00-CE	BRACKET, SWIVEL 1 SOPORTE GIRATORIO 1	1	1	UR WHITE UR WHITE
17	93700-06002	NIPPLE, GREASE BOQUILLA DE ENGRASAR	7	7	
18	6KA-82147-00	WIRE, LEAD 5 CABLE CONDUCTOR 5	1	1	
19	6G5-43144-00	HOOK, SPRING GANCHO	1	1	
20	97E95-06512	BOLT, HEXAGON W/W DEEP RECESS TORNILLO HEXAGONAL CON RONDONA	1	1	
21	61A-43181-01	LEVER, TILT STOP 1 PALANCA TOPE INCLINACION 1	1	1	
22	6G5-43185-02	LEVER, TILT STOP 2 PALANCA TOPE INCLINACION 2	1	1	
23	90386-10M16	BUSH BUJE	3	3	
24	6G5-43148-00	COLLAR, DISTANCE COLLAR	2	2	



6KF1200-V280

FIG. 28 BRACKET 1

SOPORTE 1

REF. NO.	PART NO. CODIGO N°	DESCRIPTION DESCRIPCION	6KF3	6KG3	REMARKS OBSERVACIONES
25	90249-06M19	PIN PASADOR	1	1	
26	90387-10M05	COLLAR ESPACIADOR	1	1	
27	91690-30020	PIN, SPRING PASADOR DE RESORTE	2	2	
28	90506-16003	SPRING, TENSION RESORTE DE TENSION	1	1	
29	90101-12065	BOLT (L:130MM) TORNILLO (L:130MM)	4	4	FOR CAR,OTH FOR CAR,OTH
	90101-12065	BOLT (L:130MM) TORNILLO (L:130MM)	2	2	FOR NME FOR NME
30	90201-13M01	WASHER, PLATE ARANDELA PLANA	8	8	
31	90201-12426	WASHER, PLATE ARANDELA PLANA	4	4	
32	95380-12600	NUT TUERCA	8	8	
33	90101-12066	BOLT (L:150MM) TORNILLO (L:150MM)	2	2	FOR NME FOR NME
	90101-12066	BOLT (L:150MM) TORNILLO (L:150MM)	4	4	FOR BRA FOR BRA

FIG. 29 BRACKET 2

SOPORTE 2

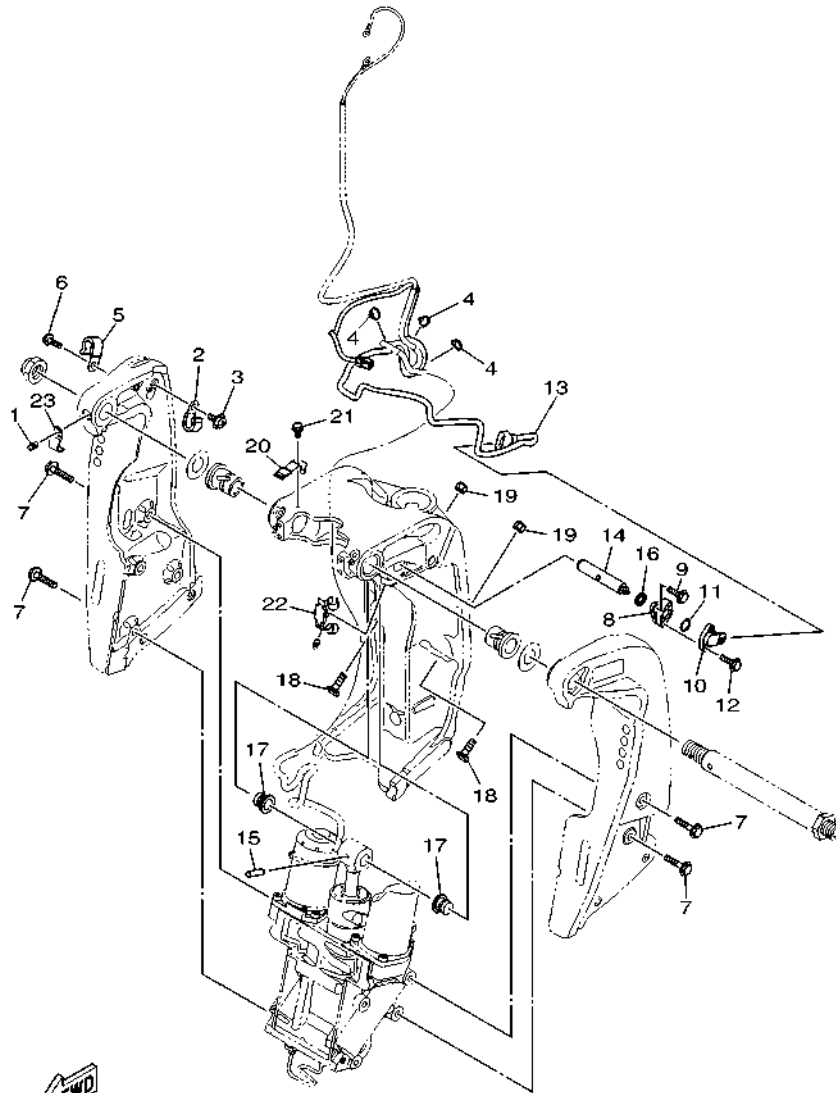

6KK2100-W300

REF. NO.	PART NO. CODIGO N°	DESCRIPTION DESCRIPCION	6KF3	6KG3	REMARKS OBSERVACIONES
1	93700-06002	NIPPLE, GREASE BOQUILLA DE ENGRASAR	1	1	
2	90465-08M83	CLAMP BRIDA	1	1	
3	97985-06212	SCREW, WITH WASHER TORNILLO, CON ARANDELA	1	1	
4	90465-11M10	CLAMP BRIDA	3	3	
5	90465-08M83	CLAMP BRIDA	1	1	
6	97585-06510	BOLT, WITH WASHER PERNO CON ARANDELA	1	1	
7	90119-10024	BOLT, WITH WASHER TORNILLO CON ARANDELA	8	8	
8	6KA-4382A-00	ADAPTOR 1 ADAPTADOR 1	1	1	
9	97595-05516	BOLT, WITH WASHER PERNO CON ARANDELA	2	2	
10	6GR-85887-00	SENSOR ANGLE SENSOR DE PAR	1	1	
11	93210-17MF9	O-RING ANILLO O	1	1	
12	97595-05516	BOLT, WITH WASHER PERNO CON ARANDELA	2	2	
13	6KF-82553-00	EXTENSION, WIRE LEAD CABLE	1	1	
14	6KA-43126-00	PIN, UPPER SHOCK MOUNT PASADOR DE AMORTIGUADOR SUPERI	1	1	
15	91690-60022	PIN, SPRING PASADOR DE RESORTE	1	1	
16	93210-06ME6	O-RING ANILLO O	1	1	
17	90386-18M14	BUSH BUJE	2	2	
18	6AW-43376-00	BOLT, THRUST RECEIVER TORNILLO RECEPTOR	2	2	
19	95780-10300	NUT, FLANGE TUERCA	2	2	
20	6KF-42829-00	PLATE, CLAMP 2 PLACA, GRAMPA 2	1	1	
21	97585-06510	BOLT, WITH WASHER PERNO CON ARANDELA	1	1	
22	6KF-42828-00	PLATE, CLAMP PLACA, GRAMPA	1	1	
23	90462-08104	CLAMP BRIDA	1	1	

FIG. 30 BRACKET 3

SOPORTE 3

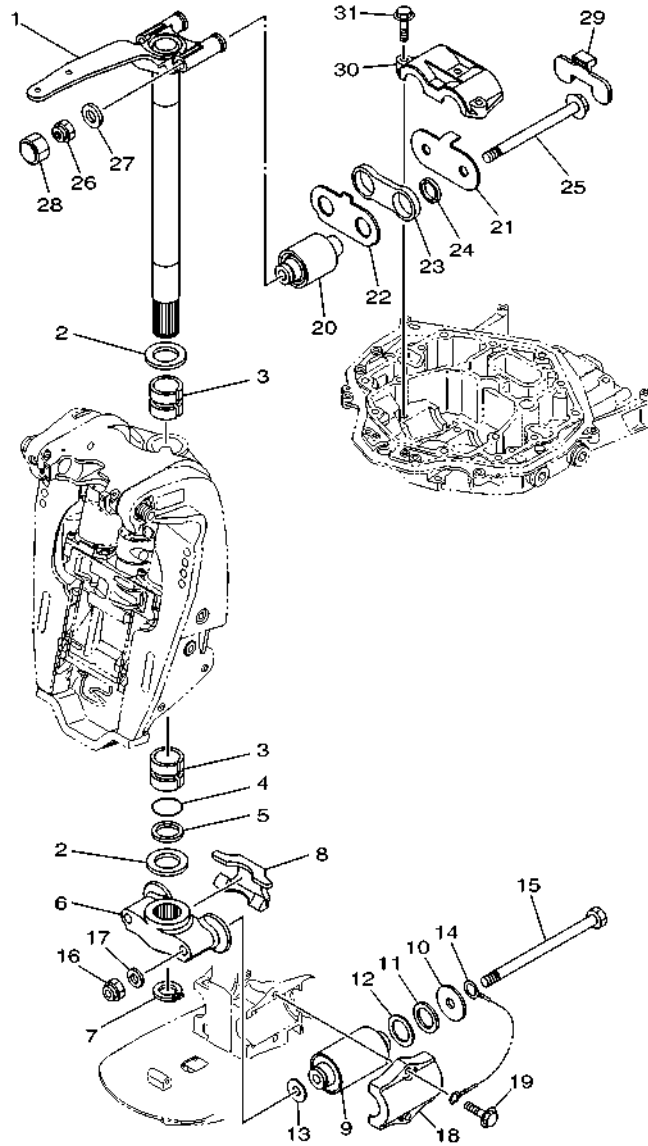

6KF1100-V310

REF. NO.	PART NO. CODIGO N°	DESCRIPTION DESCRIPCION	6KFS	6KGS	REMARKS OBSERVACIONES
1	6CE-42510-00-8D	STEERING BRACKET ASSY	1	1	UR GRAY UR GRAY UR WHITE UR WHITE
	6CE-42510-00-CE	SOPORTE DIRECCION COMPL.	1	1	
2	90201-40M00	WASHER, PLATE	2	2	
		ARANDELA PLANA			
3	90386-39M89	BUSH	2	2	
4	93210-35321	O-RING	1	1	
		ANILLO O			
5	90202-40M47	WASHER, PLATE	1	1	
		ARANDELA DE PLANA			
6	6CE-44551-00-CA	HOUSING, LOWER MOUNT RUBBER 1	1	1	
		CAJA AMORTIGUADOR INFERIOR HU			
7	93410-37M04	CIRCLIP	1	1	
		SEGURO			
8	6CE-44574-00	STOPPER, LOWER MOUNT RUBBER	1	1	
		TOPE			
9	6KA-44555-00	MOUNT DAMPER, LOWER SIDE	2	2	
		AMORTIGUADOR DE HULE LADO INFE			
10	90201-16032	WASHER, PLATE	2	2	
		ARANDELA PLANA			
11	90202-32M19	WASHER, PLATE	2	2	
		ARANDELA DE PLANA			
12	90201-35008	WASHER, PLATE	2	2	
		ARANDELA PLANA			
13	90201-15M58	WASHER, PLATE	2	2	
		ARANDELA PLANA			
14	6AW-82149-00	WIRE, LEAD 3	1	1	
		CABLE CONDUCTOR 3			
15	90101-14004	BOLT	2	2	
		TORNILLO			
16	90185-14M00	NUT, SELF-LOCKING	2	2	
		TUERCA AUTOBLOCANTE			
17	92995-14600	WASHER	2	2	
		ARANDELA			
18	6AW-44552-00-CA	HOUSING, LOWER MOUNT RUBBER 2	2	2	
		CAJA AMORTIGUADOR INFERIOR HU			
19	90119-10024	BOLT, WITH WASHER	4	4	
		TORNILLO CON ARANDELA			
20	6CE-44514-00	MOUNT DAMPER, UPPER SIDE	2	2	
		AMORTIGUADOR LADO SUPERIOR			
21	6CE-44526-00	PLATE	1	1	
		PLACA 1			
22	6CE-44536-00	PLATE 2	1	1	
		PLACA 2			
23	6CE-44532-01	STOPPER, UPPER MOUNT	1	1	
		RETEN			
24	90387-28013	COLLAR	2	2	
		ESPACIADOR			
25	90105-14005	BOLT, FLANGE	2	2	
		TORNILLO			
26	90185-14M00	NUT, SELF-LOCKING	2	2	
		TUERCA AUTOBLOCANTE			

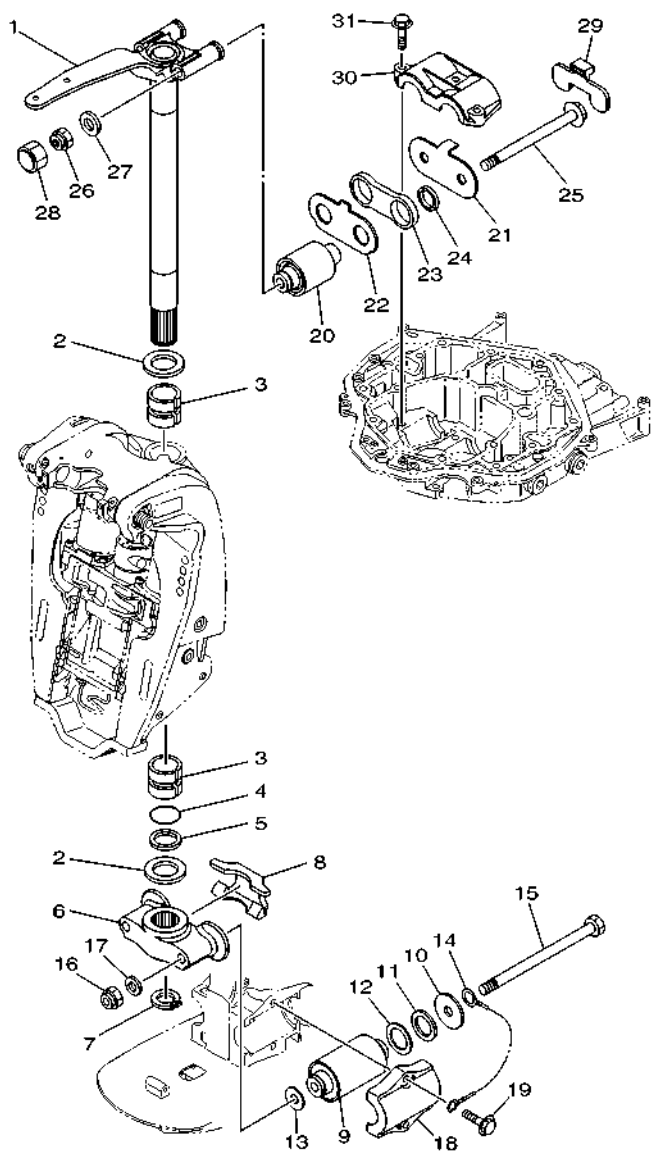

 6KF1100-V310

FIG. 30 BRACKET 3

SOPORTE 3

REF. NO.	PART NO. CODIGO N°	DESCRIPTION DESCRIPCION	6KF3	6KG3	REMARKS OBSERVACIONES
27	92995-14600	WASHER ARANDELA	2	2	
28	6CE-44194-01	CAP TAPA	2	2	
29	6CE-44533-00	DAMPER, UPPER MOUNT RUBBER AMORTIGUADOR SUPERIOR	1	1	
30	6CE-44511-00	COVER, UPPER MOUNT CUBIERTA AMORTIGUADOR SUPERIOR	1	1	
31	90119-10024	BOLT, WITH WASHER TORNILLO CON ARANDELA	3	3	
<hr/>					
<hr/>					
<hr/>					
<hr/>					
<hr/>					
<hr/>					
<hr/>					
<hr/>					
<hr/>					
<hr/>					

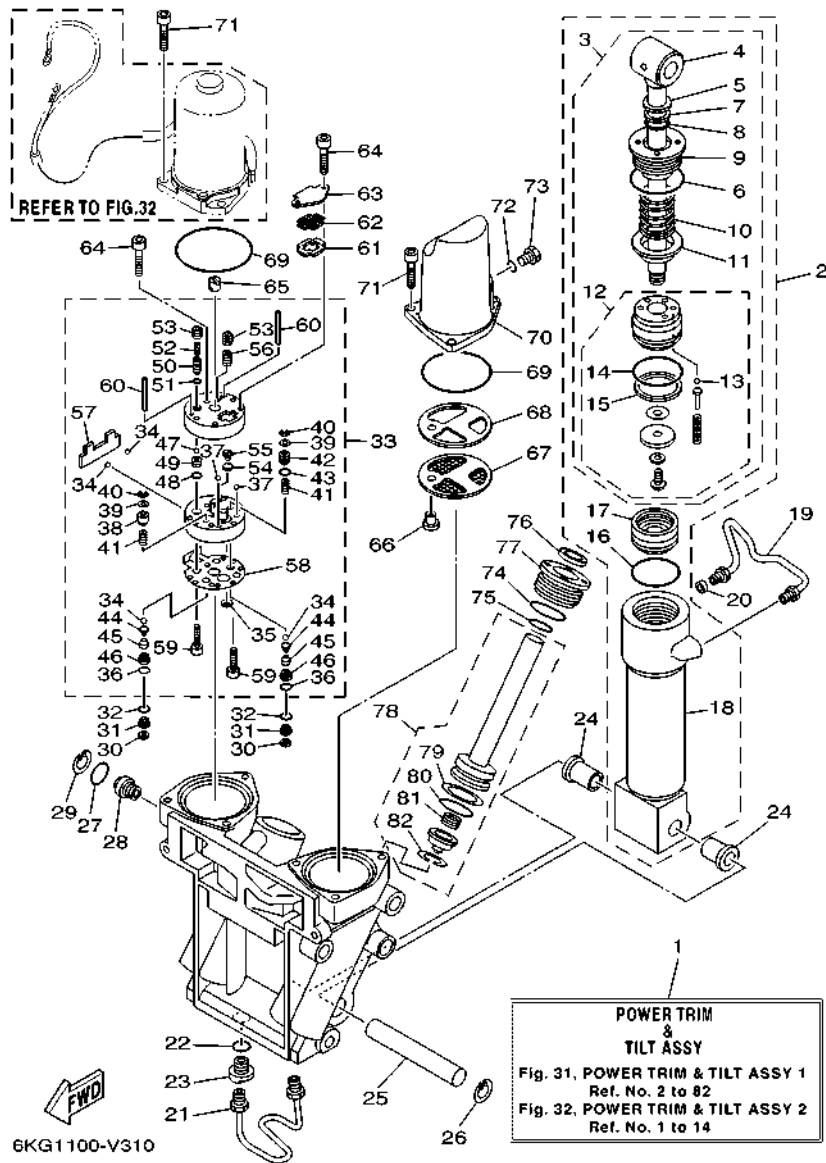

FIG. 31 POWER TRIM & TILT ASSY 1

COMPONER Y PODER VARILLA 1

REF. NO.	PART NO. CODIGO N°	DESCRIPTION DESCRIPCION	6KFS	6KGS	REMARKS OBSERVACIONES
1	6KA-43800-00-8D	POWER TRIM & TILT ASSY ELEVADOR HIDRAULICO COMPL.	1	1	UR GRAY
	6KA-43800-00-CE	POWER TRIM & TILT ASSY ELEVADOR HIDRAULICO COMPL.	1	1	UR GRAY UR WHITE UR WHITE
2	6KA-43840-00	POWER TILT ASSY CONJUNTO COMPONER	1	1	
3	6KA-43810-00	.TILT PISTON SUB ASSY .ELEVADOR SUB-PISTON COMPL.	1	1	
4	6KA-43801-00	.ROD .VALILLA COMPL INCLINACION	1	1	
5	93106-19001	.OIL SEAL .SELLO ACEITE	1	1	
6	63P-43861-20	.O-RING .ANILLO EN O 1	1	1	
7	6H1-43872-00	.RING, BACK UP .ANILLO	1	1	
8	61A-4389H-01	.O-RING .ANILLO EN O	1	1	
9	61A-43811-00	.SCREW, CYLINDER END .TORNILLO CILINDRO EXTREMO	1	1	
10	69J-4384H-00	.SPRING .RESORTE	1	1	
11	69J-4382E-00	.ADAPTOR 2 .ADAPTADOR 2	1	1	
12	6CE-4380P-00	.PISTON SUB ASSY .SUB-PISTON COMPL	1	1	
13	93505-32038	.BALL .BOLA	5	5	
14	61A-43861-00	.O-RING .ANILLO EN O 1	1	1	
15	61A-43871-00	.RING, BACK UP .ANILLO	1	1	
16	61A-43861-00	O-RING .ANILLO EN O 1	1	1	
17	6H1-43814-11	.PISTON, FREE .PISTON LIBRE	1	1	
18	61A-43813-02	.CYLINDER, TILT .CILINDRO INCLINACION	1	1	
19	69J-43835-10	PIPE TUBO 3	1	1	
20	69J-4388J-00	PLUG 2 TAPON 2	1	1	
21	69J-43833-02	PIPE TUBO 1	1	1	
22	93210-17239	O-RING ANILLO O	1	1	
23	69J-4388E-01	BOLT ,SCREW PERNO	1	1	
24	90386-18M14	BUSH BUJE	2	2	
25	61A-43818-00	PIN, LOWER SHOCK MOUNT PASADOR AMORTIGUADOR INFERIOR	1	1	
26	61A-43876-01	RING, SNAP ANILLO	1	1	

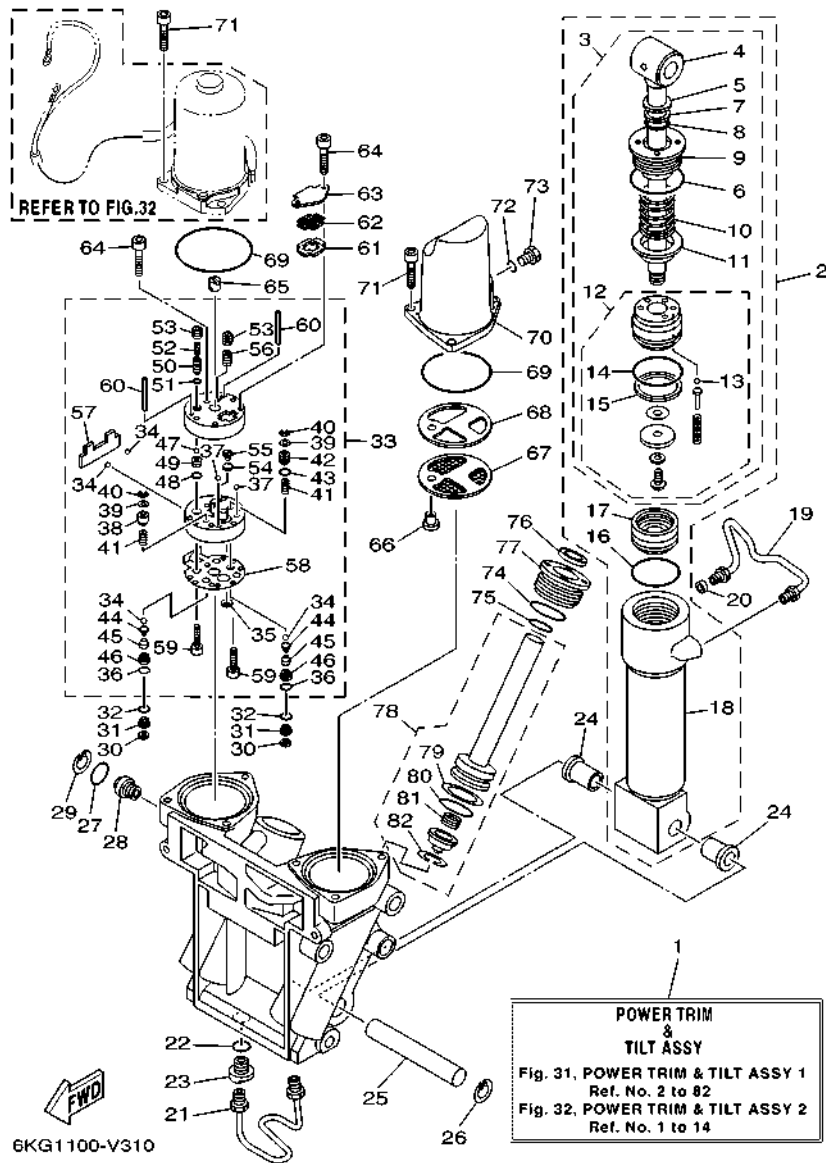

FIG. 31 POWER TRIM & TILT ASSY 1

COMPONER Y PODER VARILLA 1

REF. NO.	PART NO. CODIGO N°	DESCRIPTION DESCRIPCION	6KFS	6KGS	REMARKS OBSERVACIONES
27	6D8-43863-00	O-RING ANILLO EN O 3	1	1	
28	69J-43845-00	SCREW, MANUAL RELEASE TORNILLO DESCOPLO MANUAL	1	1	
29	6H1-43875-00	RING, SNAP ANILLO	1	1	
30	69J-4381C-00	FILTER 3 FIELTRO 3	2	2	
31	69J-43899-01	PLATE STOPPER PLACA	2	2	
32	69J-4389J-00	O-RING ANILLO O	2	2	
33	69J-43830-01	GEAR PUMP ASSY ENGRANAJE BOMBA COMPL.	1	1	
34	93505-32038	.BALL .BOLA	4	4	
35	69J-4381C-00	.FILTER 3 .FIELTRO 3	1	1	
36	69J-4389J-00	.O-RING .ANILLO O	2	2	
37	93503-16003	.BALL .ESFERA	2	2	
38	6CJ-4384M-00	.PISTON, SHUTTLE 2 .PISTON 2	1	1	
39	69A-4384F-00	.SEAL, MAIN VALVE .ASIENTO	2	2	
40	99002-03600	.CIRCLIP .PRESILLA REDONDA	2	2	
41	69J-43894-00	.SPRING, SHUTTLE RETURN .RESORTE	2	2	
42	6CJ-43841-00	.PISTON, SHUTTLE .PISTON	1	1	
43	6H1-43883-00	.O-RING .ANILLO EN O 10	1	1	
44	60V-4386A-00	.PIN, ABSORBER VALVE .PASADOR VALVULA ABSORBER	2	2	
45	69J-43853-00	.SPRING, MAIN VALVE .RESORTE	2	2	
46	6CJ-43893-00	.WASHER .RONDANA	2	2	
47	93501-08001	.BALL .BOLA	2	2	
48	93210-08391	.O-RING .ANILLO O	1	1	
49	69J-43851-00	.SEAT, RELIEF VALVE .ASIENTO VALVULA DE DESCARGA	1	1	
50	63P-43844-20	.PIN, VALVE SUPPORT .PASADOR VALVULA SOPORTE	1	1	
51	93210-064A5	.O-RING .ANILLO O	1	1	
52	69J-43855-00	.SPRING, UP RELIEF .RESORTE SEGURIDAD SUPERIOR	1	1	
53	6CJ-43843-00	.SCREW, VALVE LOCK .TORNILLO	2	2	

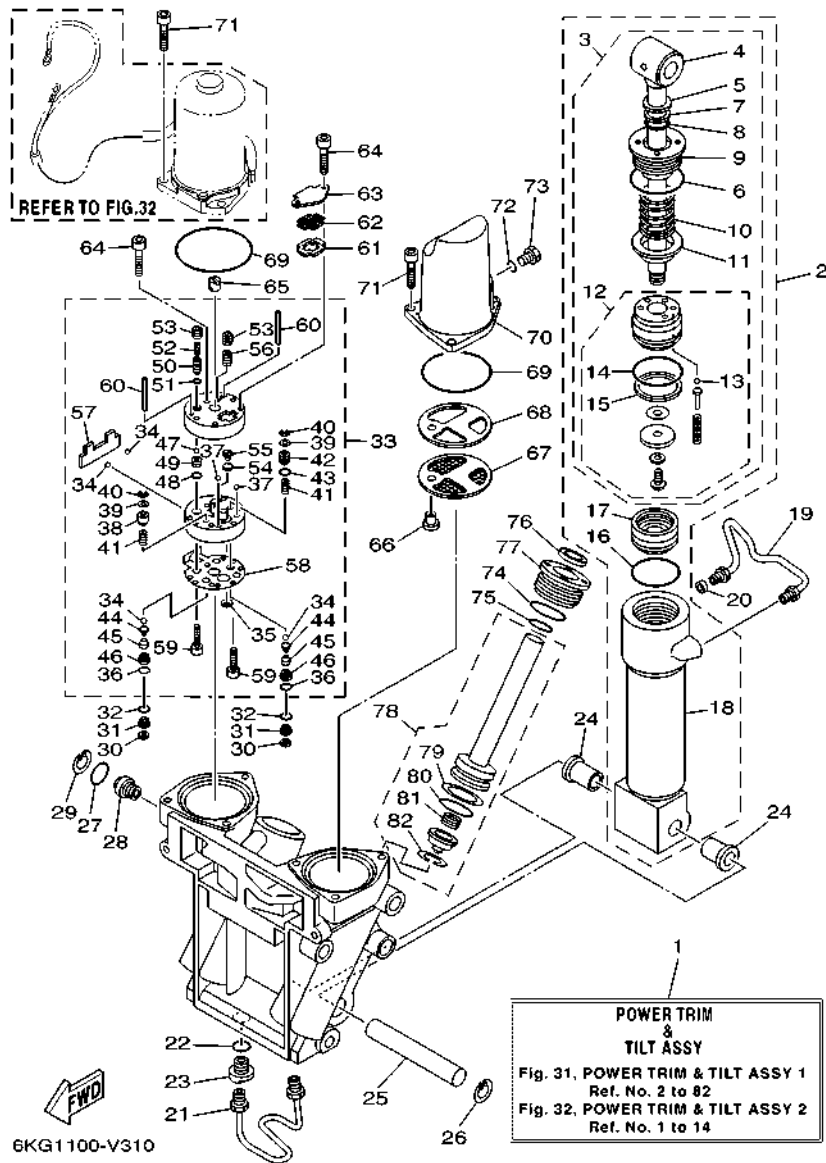

FIG. 31 POWER TRIM & TILT ASSY 1

COMPONER Y PODER VARILLA 1

REF. NO.	PART NO. CODIGO N°	DESCRIPTION DESCRIPCION	6KFS	6KGS	REMARKS OBSERVACIONES
54	6H1-4384G-11	.SEAL, RELIEF VALVE .ASIENTO	1	1	
55	6H1-43844-10	.PIN, VALVE SUPPORT .PASADOR VALVULA SOPORTE	1	1	
56	6H1-43856-10	.SPRING, DOWN RELIEF .RESORTE SEGURIDAD	1	1	
57	69J-43854-00	.SPRING, MANUAL RELEASE .RESORTE DESCOPLO MANUAL	1	1	
58	69J-4384G-00	.SEAL, RELIEF VALVE .ASIENTO	1	1	
59	91318-05025	.BOLT .TORNILLO	2	2	
60	93604-35236	.PIN, DOWEL .PASADOR DE CLAVIJA	2	2	
61	69J-43871-00	RING, BACK UP ANILLO	1	1	
62	69J-43816-00	FILTER 1 FIELTRO 1	1	1	
63	69J-4381J-00	PLATE PLACA	1	1	
64	91318-05040	BOLT TORNILLO	3	3	
65	69J-43831-00	CONNECTOR, SHAFT CONEXION EJE	1	1	
66	69J-4388H-00	PLUG TAPON	1	1	
67	69J-43817-00	FILTER 2 FIELTRO 2	1	1	
68	69J-4388F-00	SPACER ESPACIADOR	1	1	
69	93210-66001	O-RING ANILLO O	2	2	
70	6KA-43828-00	BODY, RESERVOIR CUERPO DEPOSITO	1	1	
71	69J-43888-00	BOLT, SOCKET TORNILLO ENCASTRE	6	6	
72	93210-09165	O-RING ANILLO O	1	1	
73	6H1-43829-00	PLUG, RESERVOIR TAPON DEPOSITO	1	1	
74	61A-43861-00	O-RING ANILLO EN O 1	2	2	
75	6D8-43863-00	O-RING ANILLO EN O 3	2	2	
76	63P-43812-20	SEAL, DUST SELLO DE POLVO	2	2	
77	61A-43821-02	SCREW, TRIM CYLINDER END TORNILLO CILINDRO EXTREMO	2	2	
78	69J-43820-01	TRIM PISTON SUB ASSY ELEVADOR PISTON COMPL.	2	2	
79	61A-43874-00	.RING, BACK UP .ANILLO	1	1	
80	61A-43864-00	.O-RING .ANILLO EN O 4	1	1	

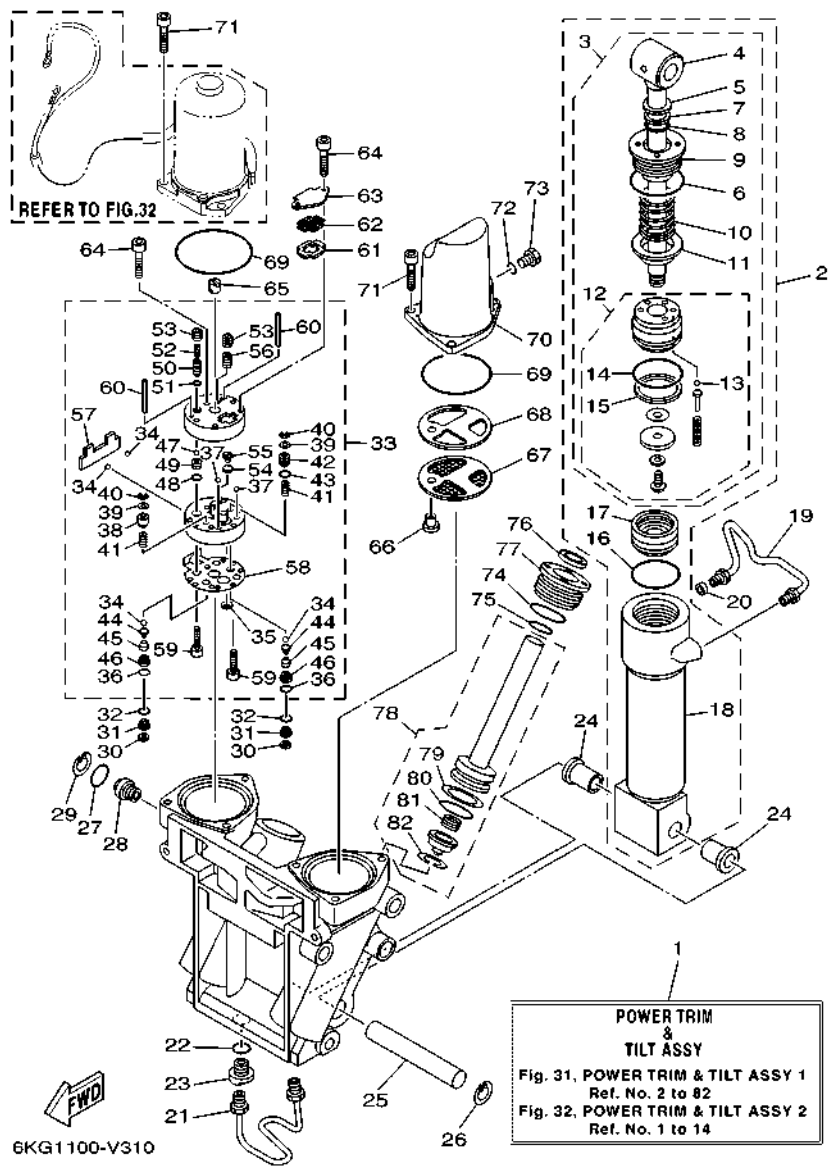

FIG. 31 POWER TRIM & TILT ASSY 1

COMPONER Y PODER VARILLA 1

REF. NO.	PART NO. CODIGO N°	DESCRIPTION DESCRIPCION	6KFS	6KGS	REMARKS OBSERVACIONES
81	61A-4384H-10	.SPRING .RESORTE	1	1	
82	61A-43875-10	.RING, SNAP .ANILLO	1	1	

FIG. 32 POWER TRIM & TILT ASSY 2

COMPONER Y PODER VARILLA 2

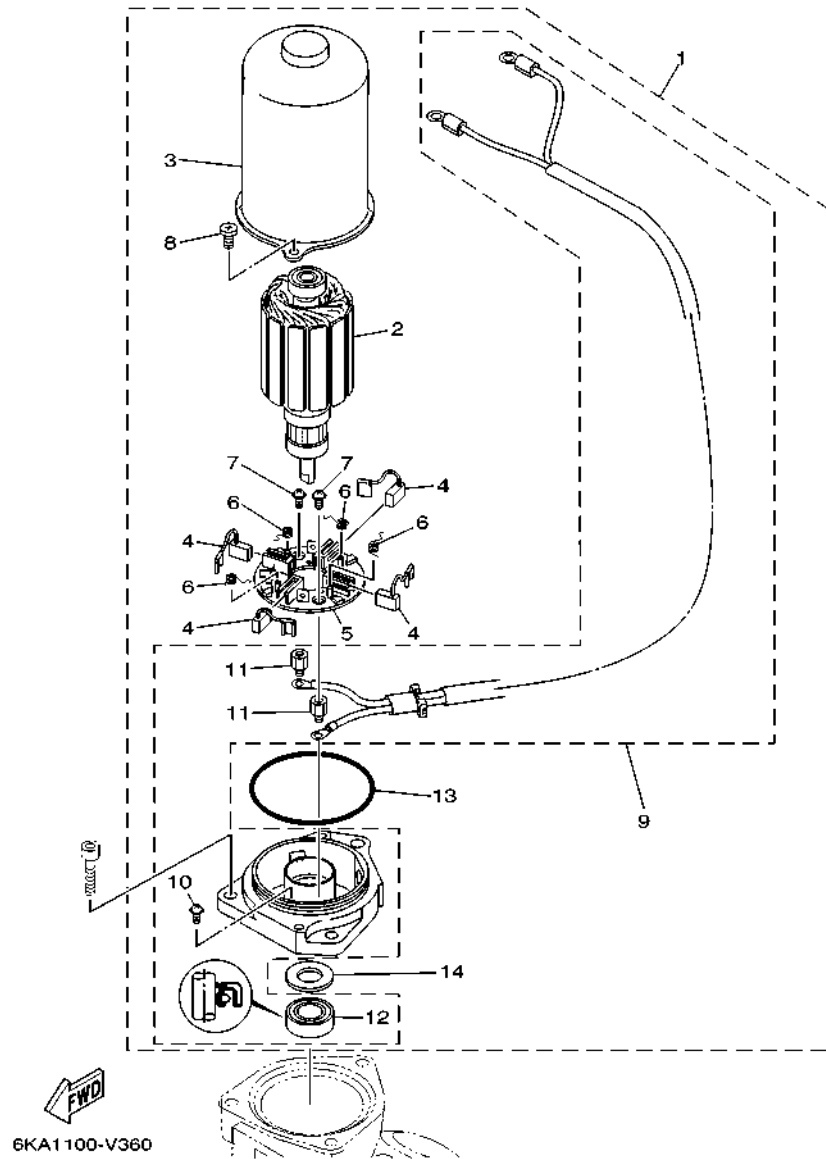

REF. NO.	PART NO. CODIGO N°	DESCRIPTION DESCRIPCION	6KFS	6KGS	REMARKS OBSERVACIONES
1	6KA-43880-00	MOTOR ASSY MOTOR COMPL.	1	1	
2	6KA-43805-00	.ARMATURE ASSY .INDUCIDO COMPL.	1	1	
3	6KA-43804-01	.STATOR ASSY .ESTATOR COMPL	1	1	
4	6KA-43892-00	.BRUSH 2 .ESCOBILLA 2	4	4	
5	6KA-43806-00	.BRUSH HOLDER ASSY .ESCOBILLA SOSTEN COMPL.	1	1	
6	6KA-4386K-00	.SPRING, BRUSH .RESORTE, ESCOBILLA	4	4	
7	97602-04306	.SCREW, PAN HEAD WITH WASHER .TORNILLO CON RONDONA	2	2	
8	6KA-43879-00	.SCREW, WITH WASHER .TORNILLO CON RONDANA	2	2	
9	6KA-43881-01	.FRAME, END .CUADRO EXTERMO	1	1	
10	97602-04308	.SCREW, PAN HEAD WITH WASHER .TORNILLO CON RONDONA	1	1	
11	6KA-4388F-00	.SPACER .ESPACIADOR	2	2	
12	6KA-43882-00	.OIL SEAL .SELLO ACEITE	1	1	
13	6KA-43862-00	.O-RING .ANILLO EN O 2	1	1	
14	6KA-4387G-00	.WASHER .ARANDELA	1	1	

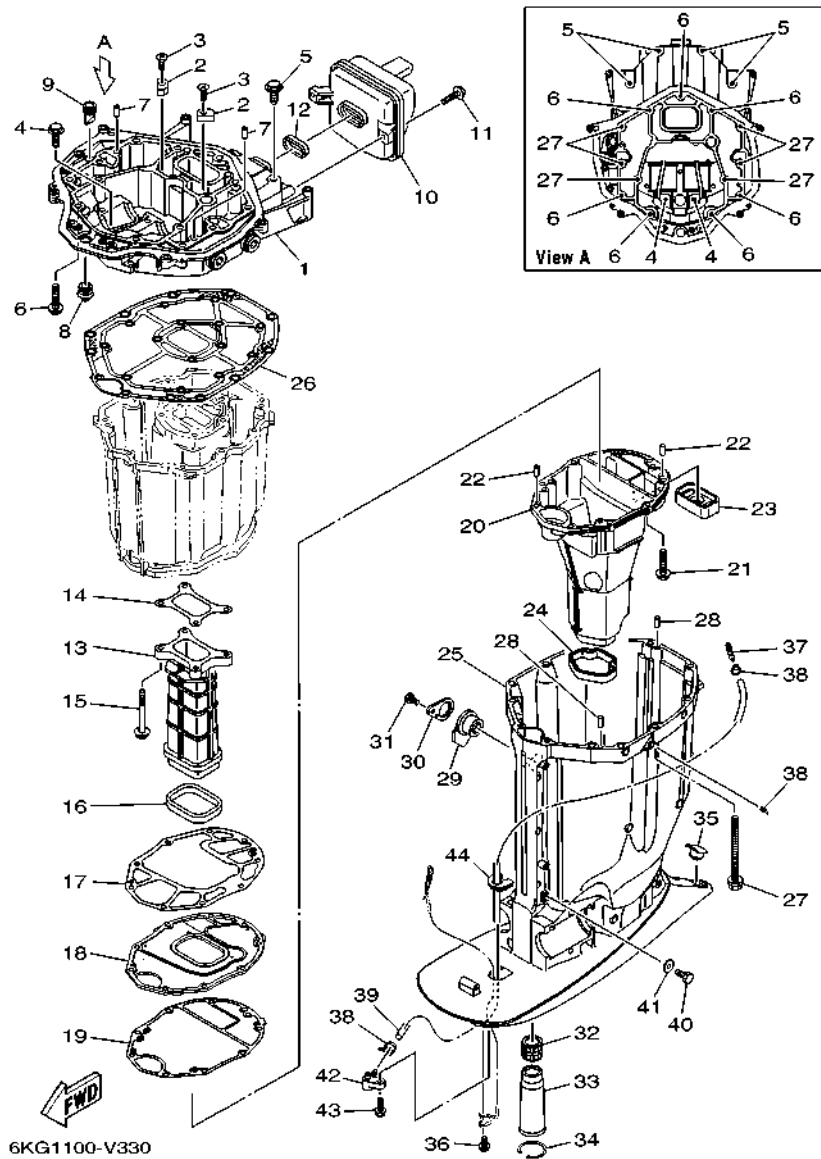

FIG. 33 UPPER CASING

FUNDA SUPERIOR

REF. NO.	PART NO. CODIGO N°	DESCRIPTION DESCRIPCION	6KFS	6KGS	REMARKS OBSERVACIONES
1	6CE-41137-01	GUIDE, EXHAUST GUIA DE ESCAPE	1	1	
2	63P-11325-11	ANODE ANODO	2	2	
3	90151-06M02	SCREW, COUNTERSUNK TORNILLO EMBUTIDO	2	2	
4	90119-08182	BOLT, WITH WASHER TORNILLO CON ARANDELA	2	2	
5	97E75-10545	BOLT, HEXAGON W/W DEEP RECESS TORNILLO HEXAGONAL CON RONDONA	4	4	
6	97E75-10535	BOLT, HEXAGON W/W DEEP RECESS TORNILLO HEXAGONAL CON RONDONA	7	7	
7	93608-16M16	PIN, DOWEL PASADOR DE CLAVIJA	2	2	
8	6E5-42724-01	GROMMET TAPON	1	1	
9	61A-42717-00	RUBBER, SEAL 2 GOMA	1	1	
10	6CB-14750-A0	SILENCER ASSY SILENCIADOR COMPLETO	1	1	
11	95D95-06020	BOLT, FLANGÉ DEEP RECESS CERROJO, REBORDE HUECO PROFUND	2	2	
12	6CB-14755-01	GASKET, SILENCER EMPAQUE DE SILENCIADOR	1	1	
13	6CB-41132-01	MANIFOLD, EXHAUST TUBO MULTIPLE DE ESCAPE	1	1	
14	6CB-41134-00	GASKET, EXHAUST MANIFOLD EMPAQUE	1	1	
15	97E75-08560	BOLT, HEXAGON W/W DEEP RECESS TORNILLO HEXAGONAL CON RONDONA	4	4	
16	6CB-41138-00	SEAL, EXT. 1 SELLO, ESCAPE 1	1	1	
17	6CB-41135-00	GASKET, EXHAUST MANIFOLD EMPAQUE	1	1	
18	6KA-45181-00	PLATE PLACA	1	1	
19	6CE-41136-00	GASKET, EXHAUST MANIFOLD 4 EMPAQUE	1	1	
20	6KA-14711-00	MUFFLER 1 SILENCIADOR 1	1	1	
21	97E75-08535	BOLT, HEXAGON W/W DEEP RECESS TORNILLO HEXAGONAL CON RONDONA	9	9	
22	93606-19M23	PIN, DOWEL PASADOR DE CLAVIJA	2	2	
23	6CE-45127-00	SEAL SELLO DE GOMA	1	1	
24	6CE-45123-00	GASKET, MUFFLER EMPAQUE SILENCIADOR	1	1	
25	6KA-45111-00-8D	CASING, UPPER CAJA SUPERIOR	1	1	UR GRAY UR GRAY
	6KA-45111-00-CE	CASING, UPPER CAJA SUPERIOR	1	1	UR WHITE UR WHITE
26	6CB-45113-10	GASKET, UPPER CASING EMPAQUE	1	1	

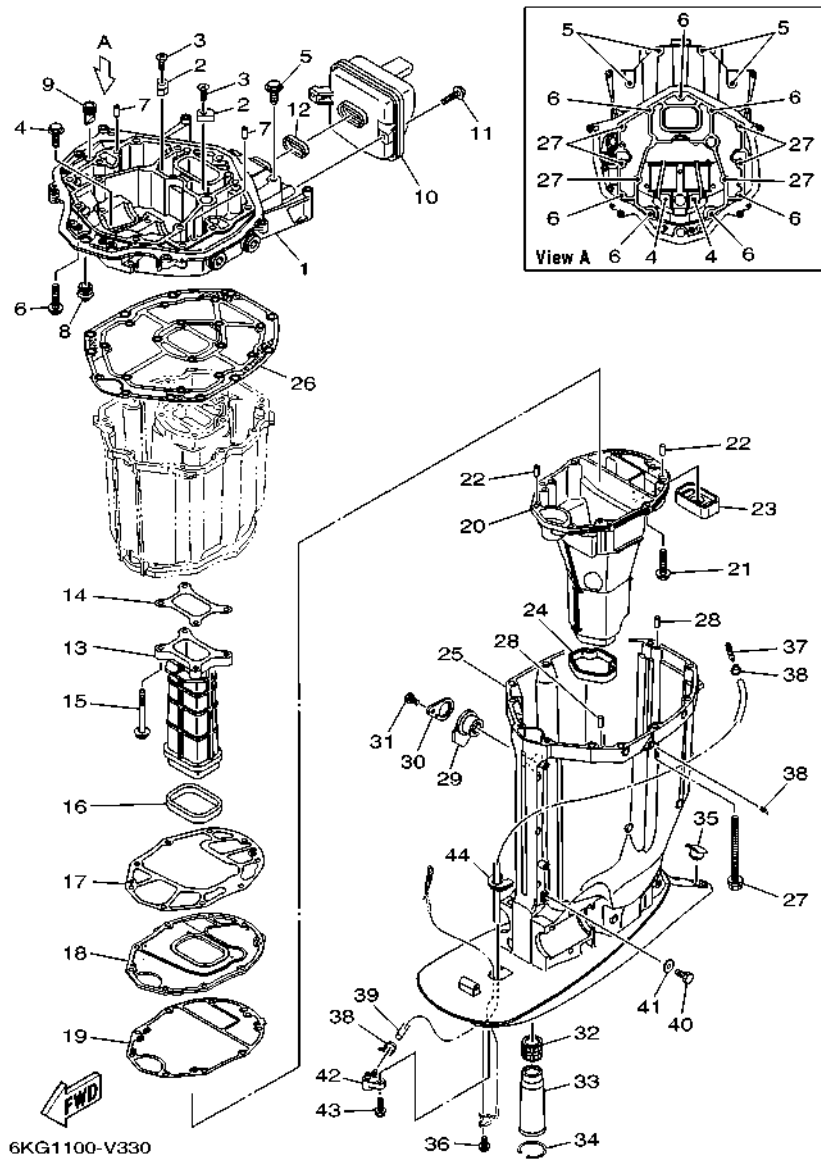

FIG. 33 UPPER CASING

FUNDA SUPERIOR

REF. NO.	PART NO. CODIGO N°	DESCRIPTION DESCRIPCION	6KFS	6KGS	REMARKS OBSERVACIONES
27	90119-10007	BOLT, WITH WASHER TORNILLO CON ARANDELA	6	6	
28	93608-16M16	PIN, DOWEL PASADOR DE CLAVIJA	2	2	
29	6BB-15316-01	DAMPER 1 AMORTIGUADOR 1	1	1	
30	6BB-45152-01	COVER, UPPER CASING 2 CUBIERTA FUNDA SUPERIOR 2	1	1	
31	97D95-06012	BOLT, HEXAGON DEEP RECESS TORNILLO HEXAGONAL	1	1	
32	69J-45318-01	BUSHING, DRIVE SHAFT BUJE, EJE DE MANDO	1	1	
33	6KA-46153-00	COLLAR, GUIDE COLLAR DE GUIA	1	1	
34	93420-50093	CIRCLIP SEGURO	1	1	
35	61A-45155-01	CAP TAPA	1	1	
36	95D95-06010	BOLT, FLANGE DEEP RECESS CERROJO, REBORDE HUECO PROFUND	1	1	
37	6E5-83558-00	END, NIPPLE EXTREMO DE NIPLE	1	1	
38	90465-11M10	CLAMP BRIDA	3	3	
39	6KF-46894-00	HOSE MANGUERA	1	1	
40	97D95-06010	BOLT, HEXAGON DEEP RECESS TORNILLO HEXAGONAL	1	1	
41	90201-06M02	WASHER, PLATE ARANDELA PLANA	1	1	
42	63P-45379-00	NIPPLE, HOSE NIPLE DE MANGUERA	1	1	
43	90119-06287	BOLT, WITH WASHER TORNILLO CON ARANDELA	1	1	
44	6KA-44521-00	SEAL SELLO DE GOMA	1	1	

FIG. 34 OIL PAN

OIL PAN

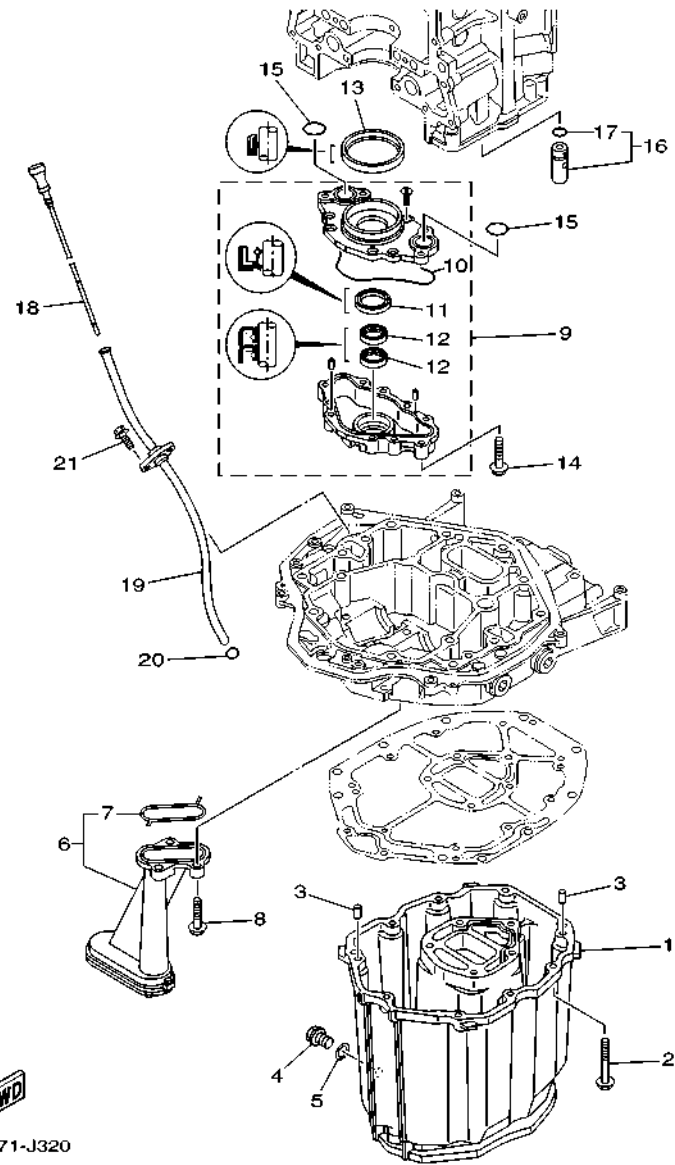

6CB1171-J320

REF. NO.	PART NO. CODIGO N°	DESCRIPTION DESCRIPCION	OIL PAN		REMARKS OBSERVACIONES
			6KFS	6KG3	
1	6CB-15311-01	OIL PAN BANDEJA DE ACEITE	1	1	
2	97E75-08535	BOLT, HEXAGON W/W DEEP RECESS TORNILLO HEXAGONAL CON RONDONA	10	10	
3	93608-16M16	PIN, DOWEL PASADOR DE CLAVIJA	2	2	
4	90340-14M06	PLUG, STRAIGHT SCREW TORNILLO, DE DRENAJE	1	1	
5	90430-14M09	GASKET JUNTA	1	1	
6	6CB-13411-00	STRAINER, OIL FILTRO DE ACEITE	1	1	
7	6AW-13415-00	.SEAL, OIL STRAINER .SELLO COLADOR ACEITE	1	1	
8	95812-06025	BOLT, FLANGE TORNILLO DE REBORDE	3	3	
9	6CB-13300-00	OIL PUMP ASSY BOMBA DE ACEITE COMPLETA	1	1	
10	6CB-13329-00	.GASKET, PUMP COVER .EMPAQUE TAPA DE BOMBA	1	1	
11	6AW-13119-00	.OIL SEAL .SELLO ACEITE	1	1	
12	69J-13631-00	.OIL SEAL .SELLO ACEITE	2	2	
13	6CB-11355-00	SEAL, CYLINDER 1 RETEN ACEITE CILINDRO 1	1	1	
14	95D75-06040	BOLT, FLANGE DEEP RECESS CERROJO, REBORDE HUECO PROFUND	4	4	
15	93210-26658	O-RING ANILLO O	2	2	
16	6CB-13490-00	RELIEF VALVE ASSY VALVELA DE DESCOMPRESION	1	1	
17	6CB-13473-00	.O-RING .ANILLO O	1	1	
18	6CB-15362-00	PLUG, OIL LEVEL TAPON DEL NIVEL DE ACEITE	1	1	
19	6CB-15377-00	GUIDE, INLET GUIA DE ENTRADA	1	1	
20	93210-19MJ3	O-RING ANILLO O	1	1	
21	95D95-06016	BOLT, FLANGE DEEP RECESS CERROJO, REBORDE HUECO PROFUND	2	2	

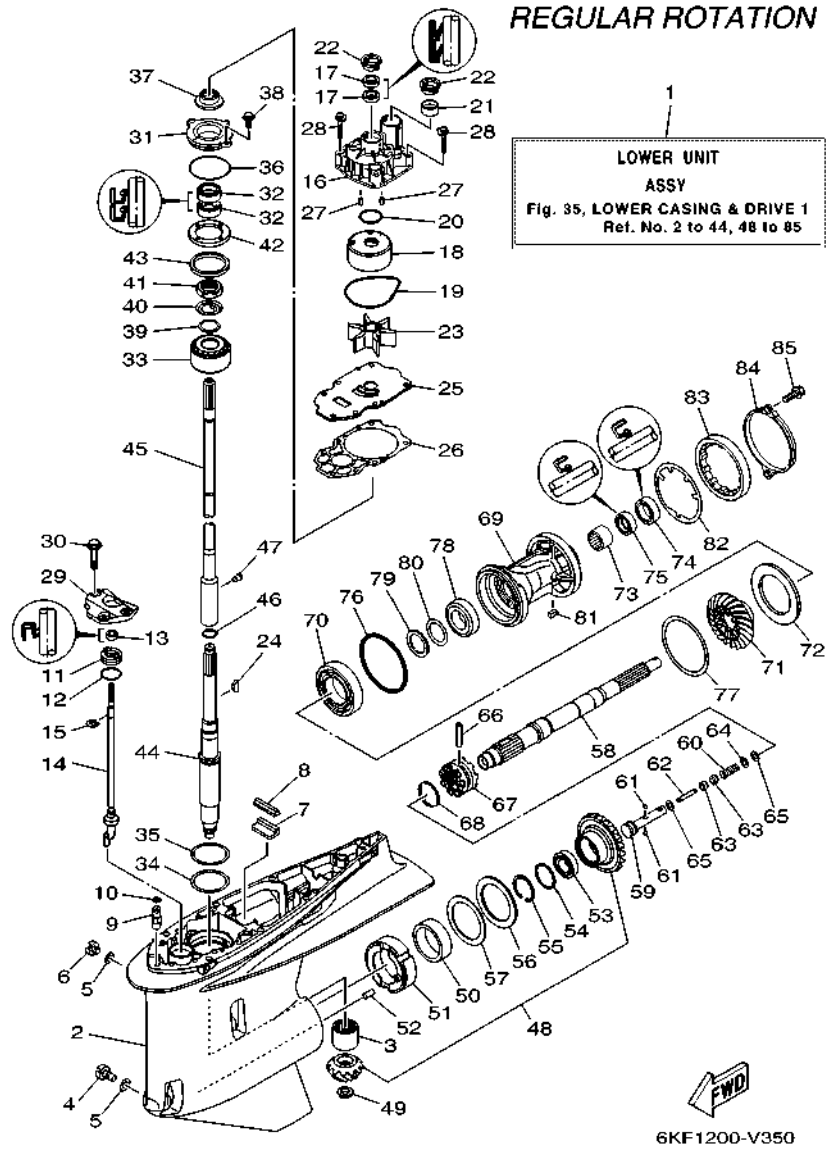

FIG. 35 LOWER CASING & DRIVE 1

IMPULSOR E INFERIOR 1

REF. NO.	PART NO. CODIGO N°	DESCRIPTION DESCRIPCION	6KFS	6KGS	REMARKS OBSERVACIONES
1	6KA-45300-00-8D	LOWER UNIT ASSY CONJUNTO UNIDAD INFERIOR	1		UR GRAY, RH UR GRAY, RH
	6KA-45300-00-CE	LOWER UNIT ASSY CONJUNTO UNIDAD INFERIOR	1		UR WHITE, RH UR WHITE, RH
2	6KA-45301-00-8D	CASING, LOWER FUNDA INFERIOR COMPLETA	1		UR GRAY UR GRAY
	6KA-45301-00-CE	CASING, LOWER FUNDA INFERIOR COMPLETA	1		UR WHITE UR WHITE
3	93311-83280	BEARING COJINETE DE RODILLOS	1		
4	688-45341-10	PLUG, DRAIN TAPON, DREN	1		
5	90430-08003	GASKET JUNTA	2		
6	90340-08002	PLUG, STRAIGHT SCREW TORNILLO, DE DRENAJE	1		
7	663-45376-00	GUIDE, SEAL DAMPER GUIA DE SELLO GOMA	1		
8	6CE-45375-00	DAMPER, SEAL GOMA DE SELLO	1		
9	63P-45378-00	NIPPLE, HOSE NIPLE MANGUERA	1		
10	93210-07003	O-RING ANILLO O	1		
11	6CE-45321-20	PLATE PLACA	1		
12	93210-33M49	O-RING ANILLO O	1		
13	93106-10001	OIL SEAL SELLO ACEITE	1		
14	6KA-44150-00	SHIFT CAM ASSY CONJUNTO EJE LEVA COMPL.	1		
15	99001-09600	CIRCLIP PRESILLA REDONDA	1		
16	6CE-44311-01	HOUSING, WATER PUMP CAJA BOMBA DE AGUA	1		
17	93104-22M07	OIL SEAL SELLO ACEITE	2		
18	6AW-44322-00	INSERT, CARTRIDGE CARTUCHO	1		
19	93210-94003	O-RING ANILLO O	1		
20	93210-37160	O-RING ANILLO O	1		
21	6AW-44365-01	DAMPER, WATER SEAL 1 HULE DE SELLO DE AGUA 1	1		
22	6AW-44312-00	COVER, WATER PUMP HOUSING CUBIERTA CAJA BOMBA DE AGUA	2		
23	6CE-44352-00	IMPELLER IMPULSOR	1		
24	90280-04002	KEY, WOODRUFF CUNA WOODRUFF	1		
25	6CE-44323-01	OUTER PLATE, CARTRIDGE PLACA EXTERIOR DEL CARTUCHO	1		

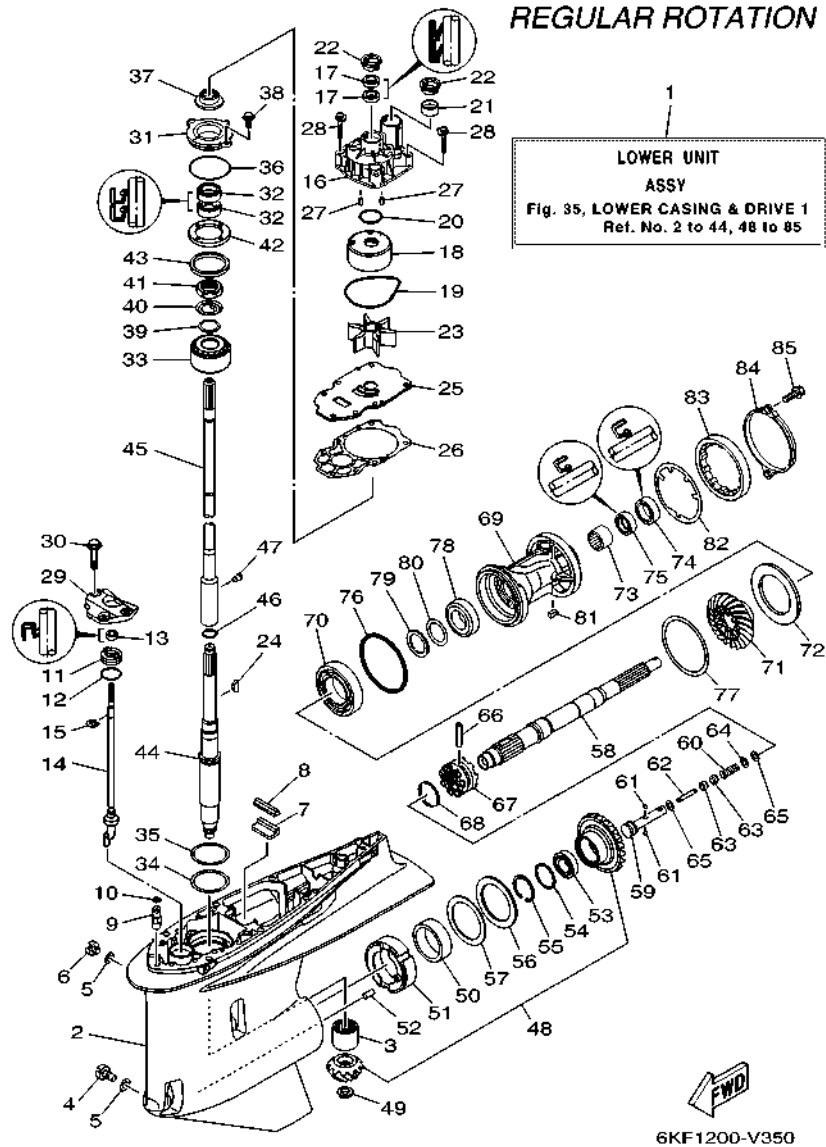

FIG. 35 LOWER CASING & DRIVE 1

IMPULSOR E INFERIOR 1

REF. NO.	PART NO. CODIGO N°	DESCRIPTION DESCRIPCION	6KF3	6KG3	REMARKS OBSERVACIONES
26	6CE-44315-00	GASKET, WATER PUMP EMPAQUE	1		
27	93606-12019	PIN, DOWEL PASADOR DE CLAVIJA	2		
28	90119-08191	BOLT, WITH WASHER TORNILLO CON ARANDELA	4		
29	6CB-44312-00	COVER, WATER PUMP HOUSING CUBIERTA CAJA BOMBA DE AGUA	1		
30	90119-08180	BOLT, WITH WASHER TORNILLO CON ARANDELA	3		
31	6AW-45335-00-CA	HOUSING, OIL SEAL CAJA DEL SELLO DE ACEITE	1		
32	93101-28019	OIL SEAL SELLO ACEITE	2		
33	93399-99962	BEARING COJINETE	1		
34	90201-68008	WASHER, PLATE ARANDELA PLANA	1		
35	6AW-45587-00	SHIM (T:0.10MM) LAINA (T:0.10MM)	1		UR UR
	6AW-45587-10	SHIM (T:0.12MM) LAINA (T:0.12MM)	1		UR UR
	6AW-45587-20	SHIM (T:0.15MM) LAINA (T:0.15MM)	1		UR UR
	6AW-45587-30	SHIM (T:0.18MM) LAINA (T:0.18MM)	1		UR UR
	6AW-45587-40	SHIM (T:0.30MM) LAINA (T:0.30MM)	1		UR UR
	6AW-45587-50	SHIM (T:0.40MM) LAINA (T:0.40MM)	1		UR UR
	6AW-45587-60	SHIM (T:0.50MM) LAINA (T:0.50MM)	1		UR UR
36	93210-69MG6	O-RING ANILLO O	1		
37	6KA-45344-00	COVER, OIL SEAL CUBIERTA SELLO ACEITE	1		
38	97E95-08520	BOLT, HEXAGON W/W DEEP RECESS TORNILLO HEXAGONAL CON RONDONA	2		
39	90201-301U7	WASHER, PLATE ARANDELA PLANA	1		
40	90214-30003	WASHER, CLAW ARANDELA DE POSICION	1		
41	90170-30M18	NUT TUERCA	1		
42	6AW-45244-00	NUT TUERCA	1		
43	6T5-45539-00	SPACER 2 ESPACIADOR 2	1		
44	6KA-45501-00	DRIVE SHAFT COMP. EJE DE MANDO COMPL.	1		
45	6KF-45802-00	INTERMEDI. DRIVE SHAFT COMP. INTERMEDIO EJE DE MANDO COMPL.	1		UR X(25.3") UR X(30.3")
	6KF-45802-10	INTERMEDI. DRIVE SHAFT COMP. INTERMEDIO EJE DE MANDO COMPL.	1		UR U(30.3") UR U(30.3")

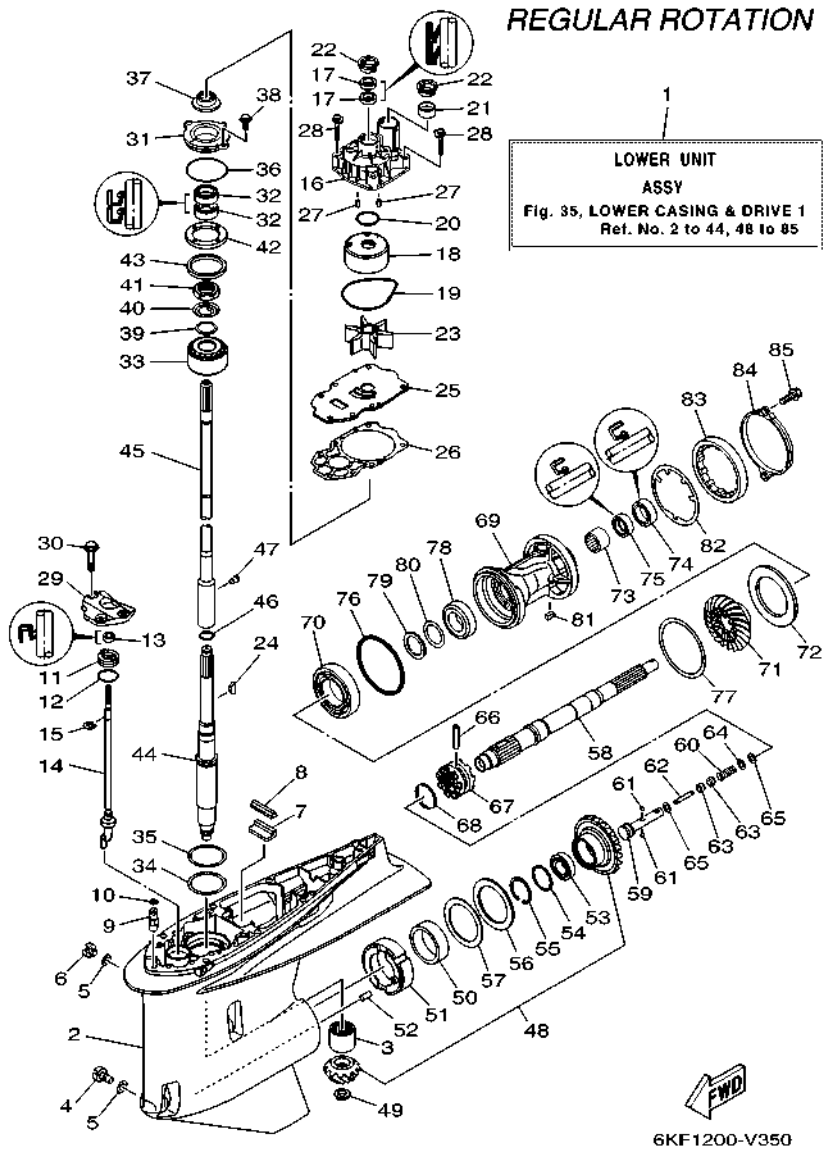

FIG. 35 LOWER CASING & DRIVE 1

IMPULSOR E INFERIOR 1

REF. NO.	PART NO. CODIGO N°	DESCRIPTION DESCRIPCION	6KFS	6KGS	REMARKS OBSERVACIONES
46	93210-22MF1	O-RING ANILLO O	1		
47	90149-05048	SCREW TORNILLO DE REGLAJE	1		
48	6KA-45550-00	GEAR SET JUEGO DE ENGRANAJE	1		
49	90179-16017	NUT TUERCA	1		
50	93311-85894	BEARING COJINETE DE RODILLOS	1		
51	6CB-45824-00	ADAPTER ADAPTADOR	1		
52	93608-16M16	PIN, DOWEL PASADOR DE CLAVIJA	1		
53	93332-000A4	BEARING COJINETE	1		
54	90201-41008	WASHER, PLATE ARANDELA PLANA	1		
55	99009-47500	CIRCLIP PRESILLA REDONDA	1		
56	93340-67011	BEARING COJINETES CON RODAMIENTOS	1		
57	6CB-45567-00	SHIM (T:2.00MM) LAINA (T:2.00MM)	1		UR
	6CB-45567-10	SHIM (T:2.03MM) LAINA (T:2.03MM)	1		UR
	6CB-45567-20	SHIM (T:2.06MM) LAINA (T:2.06MM)	1		UR
	6CB-45567-30	SHIM (T:2.09MM) LAINA (T:2.09MM)	1		UR
	6CB-45567-40	SHIM (T:2.12MM) LAINA (T:2.12MM)	1		UR
	6CB-45567-50	SHIM (T:2.15MM) LAINA (T:2.15MM)	1		UR
58	6CB-45611-00	SHAFT, PROPELLER EJE PROPUSOR	1		
59	6CB-45634-00	SLIDE, SHIFT DESILIZADOR, CAMBIO	1		
60	90501-10M77	SPRING, COMPRESSION RESORTE DE COMPRESION	1		
61	93501-04011	BALL BOLA	2		
62	6H1-45668-00	SHAFT, FREE 1 EJE 1	1		
63	61A-45635-00	PLUNGER, SHIFT EMBOLO DE CAMBIO	2		
64	90201-02M00	WASHER, PLATE ARANDELA PLANA	1		
65	90183-02M03	NUT, SPRING TUERCA DE RESORTE	2		
66	90250-08M07	PIN, STRAIGHT PASADOR CILINDRICO	1		
67	6KA-45631-00	CLUTCH, DOG EMBRAGUE DE GARRA	1		

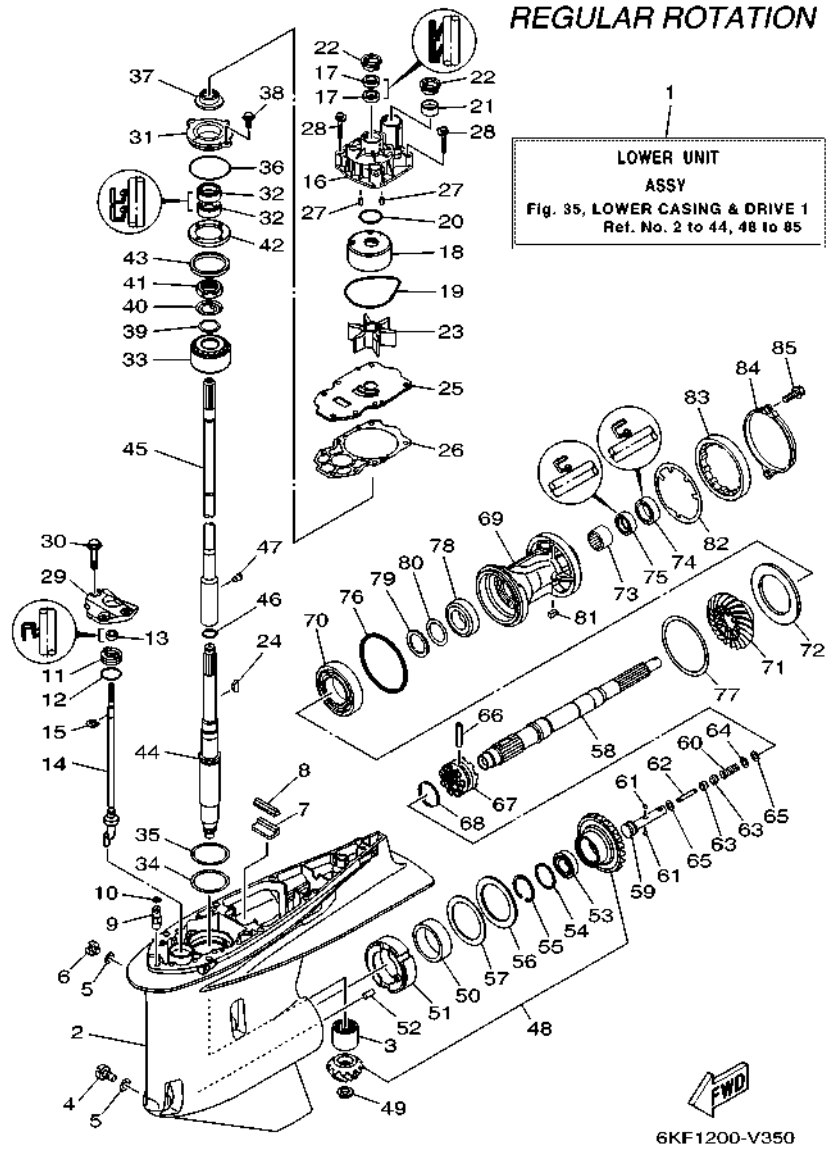

FIG. 35 LOWER CASING & DRIVE 1

IMPULSOR E INFERIOR 1

REF. NO.	PART NO. CODIGO N°	DESCRIPTION DESCRIPCION	6KF3	6KG3	REMARKS OBSERVACIONES
68	6E5-45633-01	RING, CROSS PIN ANILLO DE PASADOR	1		
69	6CE-45332-00-CA	HOUSING, BEARING CAJA BALERO 2	1		
70	93306-209U0	BEARING COJINETE	1		
71	6KA-45571-00	GEAR 2 (21T) ENGRANAJE 2 (21T)	1		
72	6CB-45576-00	WASHER, THRUST 2 ARANDELA DE EMPUJE AXIAL 2	1		
73	93315-43061	BEARING COJINETE DE RODILLOS	1		
74	93101-30030	OIL SEAL SELLO ACEITE	1		
75	93101-30019	OIL SEAL SELLO ACEITE	1		
76	93211-02001	O-RING ANILLO O	1		
77	6CB-45577-00	SHIM (T:0.10MM) LAINA (T:0.10MM)	1		UR UR
	6CB-45577-10	SHIM (T:0.12MM) LAINA (T:0.12MM)	1		UR UR
	6CB-45577-20	SHIM (T:0.15MM) LAINA (T:0.15MM)	1		UR UR
	6CB-45577-30	SHIM (T:0.18MM) LAINA (T:0.18MM)	1		UR UR
	6CB-45577-40	SHIM (T:0.30MM) LAINA (T:0.30MM)	1		UR UR
	6CB-45577-50	SHIM (T:0.40MM) LAINA (T:0.40MM)	1		UR UR
	6CB-45577-60	SHIM (T:0.50MM) LAINA (T:0.50MM)	1		UR UR
78	93332-000A5	BEARING COJINETE	1		
79	90201-32008	WASHER, PLATE ARANDELA PLANA	1		
80	676-45567-00	SHIM (T:0.7MM) LAINA (T:0.7MM)	1		UR UR
	676-45567-10	SHIM (T:0.8MM) LAINA (T:0.8MM)	1		UR UR
	676-45567-20	SHIM (T:0.9MM) LAINA (T:0.9MM)	1		UR UR
	676-45567-30	SHIM (T:1.0MM) LAINA (T:1.0MM)	1		UR UR
	676-45567-40	SHIM (T:1.1MM) LAINA (T:1.1MM)	1		UR UR
	676-45567-50	SHIM (T:1.2MM) LAINA (T:1.2MM)	1		UR UR
81	90282-05008	KEY, STRAIGHT CHAVETA, RECTA	1		
82	6CB-45383-00	WASHER, CLAW ARANDELA DE UNA	1		
83	6CB-45384-00	NUT TUERCA	1		

FIG. 35 LOWER CASING & DRIVE 1

IMPULSOR E INFERIOR 1

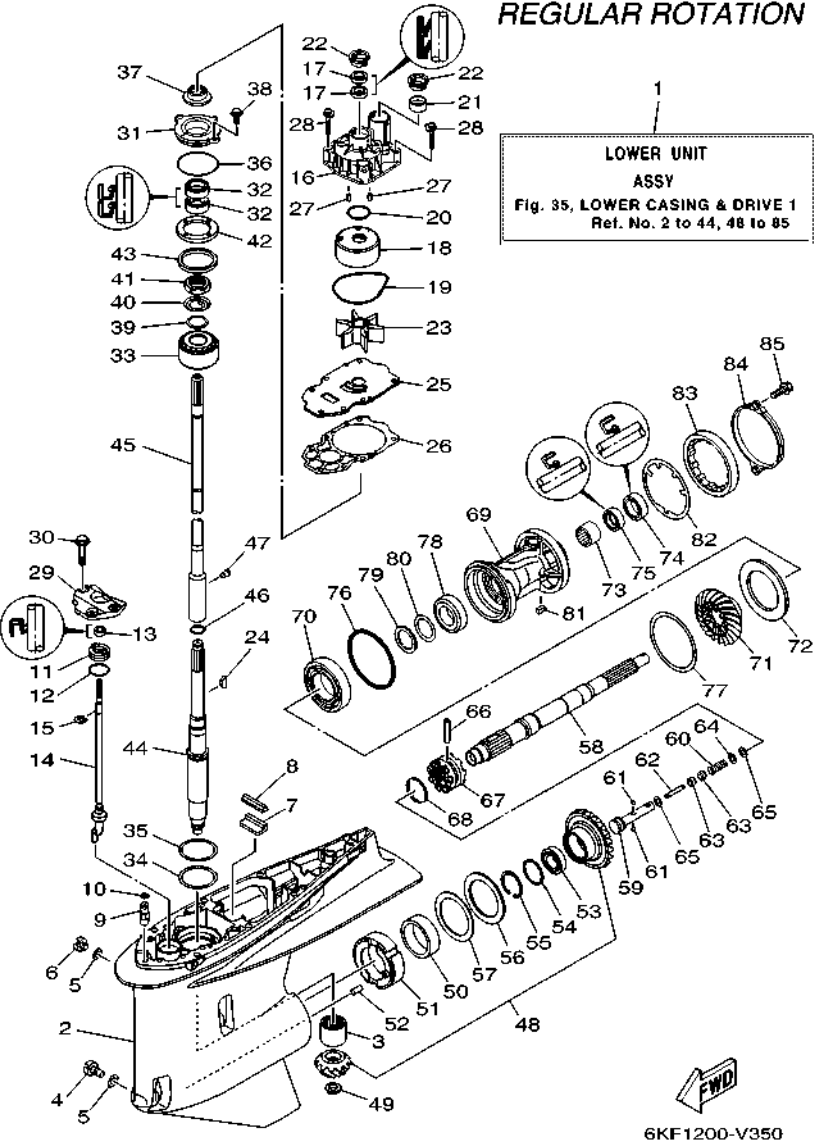

REF. NO.	PART NO. CODIGO N°	DESCRIPTION DESCRIPCION	6KF3	6KG3	REMARKS OBSERVACIONES
84	6CE-45361-10	CAP, LOWER CASING FUNDA INFERIOR	1		
85	90105-08M61	BOLT, FLANGE TORNILLO	2		

FIG. 36 LOWER CASING & DRIVE 2

IMPULSOR E INFERIOR 2

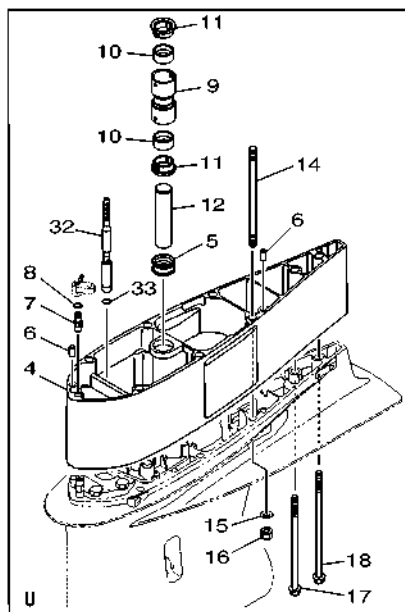

REGULAR ROTATION

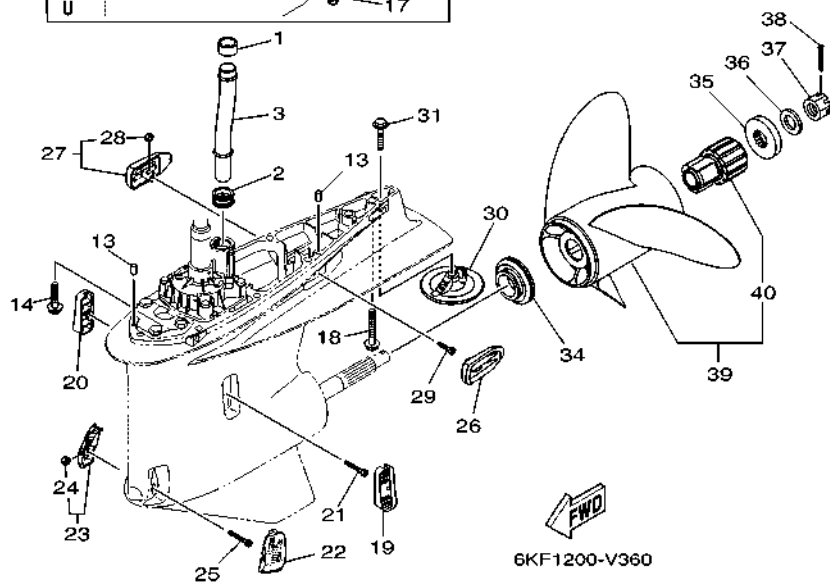

REF. NO.	PART NO. CODIGO N°	DESCRIPTION DESCRIPCION	6KFS	6KGS	REMARKS OBSERVACIONES
1	6AW-44365-01	DAMPER, WATER SEAL 1 HULE DE SELLO DE AGUA 1	1		
2	6AW-44366-01	DAMPER, WATER SEAL 2 GOMA DEL SELLO DE AGUA 2	1		
3	6CE-44361-00	TUBE, WATER 1 TUBO DE AGUA 1	1		
4	6CE-45211-10-8D	EXTENSION	1		UR GRAY, U(30.3") UR GRAY, U(30.3")
	6CE-45211-10-CE	EXTENSION	1		UR WHITE,U(30.3") UR WHITE,U(30.3")
5	6AW-44366-01	DAMPER, WATER SEAL 2 GOMA DEL SELLO DE AGUA 2	1		U(30.3") U(30.3")
6	93608-16M16	PIN, DOWEL PASADOR DE CLAVIJA	2		U(30.3") U(30.3")
7	63P-45378-00	NIPPLE, HOSE NIPLE MANGUERA	1		U(30.3") U(30.3")
8	93210-07003	O-RING ANILLO O	1		U(30.3") U(30.3")
9	6CE-44362-00	TUBE, WATER 2 TUBO DE AGUA 2	1		U(30.3") U(30.3")
10	6AW-44365-01	DAMPER, WATER SEAL 1 HULE DE SELLO DE AGUA 1	2		U(30.3") U(30.3")
11	6AW-44312-00	COVER, WATER PUMP HOUSING CUBIERTA CAJA BOMBA DE AGUA	2		U(30.3") U(30.3")
12	6AW-44363-00	TUBE, WATER 3 TUBO DE AGUA 3	1		U(30.3") U(30.3")
13	93608-16M16	PIN, DOWEL PASADOR DE CLAVIJA	2		
14	90119-10024	BOLT, WITH WASHER TORNILLO CON ARANDELA	7		UR X(25.3") UR X(25.3")
	90116-10067	BOLT, STUD ESPARRAGO	6		UR U(30.3") UR U(30.3")
15	92995-10600	WASHER ARANDELA	6		U(30.3") U(30.3")
16	95380-10600	NUT TUERCA	6		U(30.3") U(30.3")
17	90119-10009	BOLT, WITH WASHER TORNILLO CON ARANDELA	1		U(30.3") U(30.3")
18	97E75-10570	BOLT, HEXAGON W/W DEEP RECESS TORNILLO HEXAGONAL CON RONDONA	1		UR X(25.3") UR X(25.3")
	90119-10008	BOLT, WITH WASHER TORNILLO CON ARANDELA	1		UR U(30.3") UR U(30.3")
19	6KA-45214-00	COVER, WATER INLET 1 CUBIERTA, ENTRADA AGUA 1	1		
20	6KA-45215-00	COVER, WATER INLET 2 CUBIERTA, ENTRADA AGUA 2	1		
21	90110-05039	BOLT, HEXAGON SOCKET HEAD TORNILLO ALLEN	1		
22	6CE-45224-00	COVER, WATER INLET 3 CUBIERTA, ENTRADA AGUA 3	1		
23	6CE-45225-00	COVER, WATER INLET 4 CUBIERTA, ENTRADA AGUA 4	1		
24	90185-05002	.NUT, NYLON .TUERCA AUTOBLOCANTE	1		

FIG. 36 LOWER CASING & DRIVE 2

IMPULSOR E INFERIOR 2

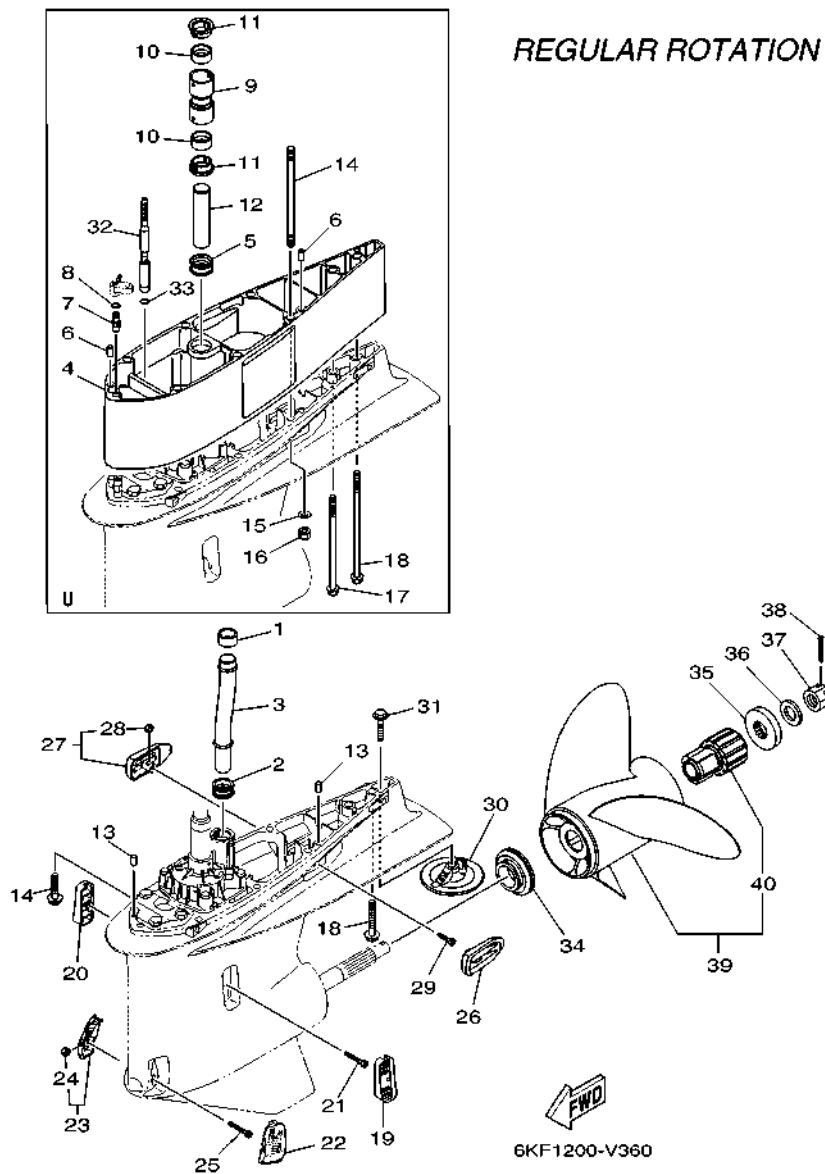

REF. NO.	PART NO. CODIGO N°	DESCRIPTION DESCRIPCION	6KF3	6KG3	REMARKS OBSERVACIONES
25	90110-05039	BOLT, HEXAGON SOCKET HEAD TORNILLO ALLEN	1		
26	6KA-45254-00	COVER, OUTLET 1 CUBIERTA, SALIDA 1	1		
27	6KA-45255-00	COVER, OUTLET 2 CUBIERTA, SALIDA 2	1		
28	90185-05002	.NUT, NYLON .TUERCA AUTOBLOCANTE	1		
29	91380-05020	BOLT PERNO	1		
30	6CE-45373-00	ANODE ANODO	1		
31	90105-10M00	BOLT, FLANGE TORNILLO	1		
32	6KA-44190-00	JT. SHIFT ROD COMP. JUNTA VARILLA EJE COMPL.	1		U(30.3") U(30.3")
33	93210-09165	O-RING ANILLO O	1		U(30.3") U(30.3")
34	69J-45987-00	SPACER 1 ESPACIADOR 1	1		
35	688-45997-01	SPACER 2 ESPACIADOR 2	1		
36	92990-18200	WASHER ARANDELA PLANA	1		
37	90171-18M04	NUT, CASTLE TUERCA ENTALLADA	1		
38	91490-40030	PIN, COTTER CHAVETA	1		
39	6KA-45970-00	PROPELLER (3X15-1/4"X18"-T) PROPELA (3X15-1/4"X18"-T)	1		UR UR
	6KA-45972-00	PROPELLER (3X15-1/4"X19"-T) PROPELA (3X15-1/4"X19"-T)	1		UR UR
	6KA-45974-00	PROPELLER (3X15"X20"-T) PROPELA (3X15"X20"-T)	1		UR UR
	6KA-45976-00	PROPELLER (3X15"X21"-T) PROPELA (3X15"X21"-T)	1		UR UR
	6CE-45970-20	PROPELLER (3X15-1/4"X19"-T) PROPELA (3X15-1/4"X19"-T)	1		UR FOR OTH UR FOR OTH
	6CE-45978-20	PROPELLER (3X15-1/2"X17"-T) PROPELA (3X15-1/2"X17"-T)	1		UR FOR BRA UR FOR BRA
40	6CE-45C81-10	.DAMPER RUBBER, PROPELLER 1 .AMORTIGUADOR PROPELA 1	1		

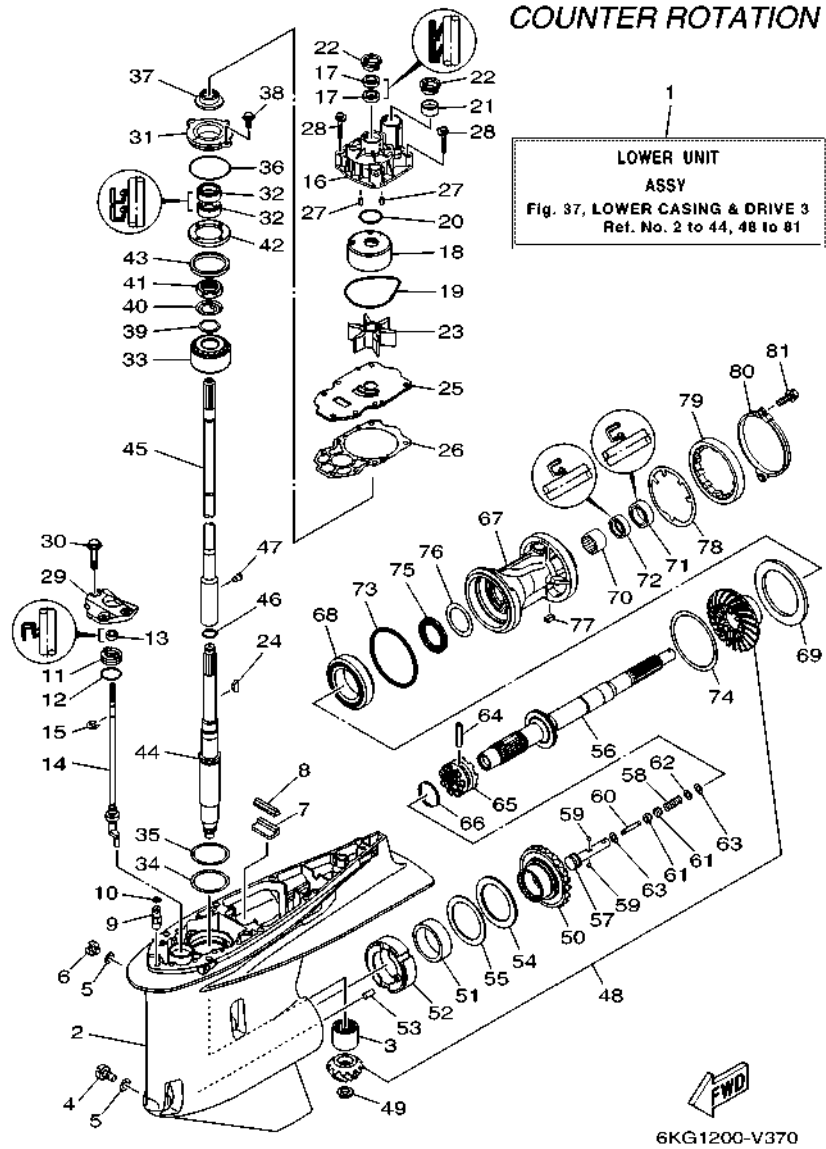

FIG. 37 LOWER CASING & DRIVE 3

IMPULSOR E INFERIOR 3

REF. NO.	PART NO. CODIGO N°	DESCRIPTION DESCRIPCION	6KFS	6KG3	REMARKS OBSERVACIONES
1	6KB-45300-00-8D	LOWER UNIT ASSY CONJUNTO UNIDAD INFERIOR		1	UR GRAY, LH
	6KB-45300-00-CE	LOWER UNIT ASSY CONJUNTO UNIDAD INFERIOR		1	UR WHITE, LH
2	6KA-45301-00-8D	CASING, LOWER FUNDA INFERIOR COMPLETA		1	UR GRAY
	6KA-45301-00-CE	CASING, LOWER FUNDA INFERIOR COMPLETA		1	UR WHITE
3	93311-83280	BEARING COJINETE DE RODILLOS		1	UR WHITE
4	688-45341-10	PLUG, DRAIN TAPON, DREN		1	
5	90430-08003	GASKET JUNTA		2	
6	90340-08002	PLUG, STRAIGHT SCREW TORNILLO, DE DRENAJE		1	
7	663-45376-00	GUIDE, SEAL DAMPER GUIA DE SELLO GOMA		1	
8	6CE-45375-00	DAMPER, SEAL GOMA DE SELLO		1	
9	63P-45378-00	NIPPLE, HOSE NIPLE MANGUERA		1	
10	93210-07003	O-RING ANILLO O		1	
11	6CE-45321-20	PLATE PLACA		1	
12	93210-33M49	O-RING ANILLO O		1	
13	93106-10001	OIL SEAL SELLO ACEITE		1	
14	6KB-44150-00	SHIFT CAM ASSY CONJUNTO EJE LEVA COMPL.		1	
15	99001-09600	CIRCLIP PRESILLA REDONDA		1	
16	6CE-44311-01	HOUSING, WATER PUMP CAJA BOMBA DE AGUA		1	
17	93104-22M07	OIL SEAL SELLO ACEITE		2	
18	6AW-44322-00	INSERT, CARTRIDGE CARTUCHO		1	
19	93210-94003	O-RING ANILLO O		1	
20	93210-37160	O-RING ANILLO O		1	
21	6AW-44365-01	DAMPER, WATER SEAL 1 HULE DE SELLO DE AGUA 1		1	
22	6AW-44312-00	COVER, WATER PUMP HOUSING CUBIERTA CAJA BOMBA DE AGUA		2	
23	6CE-44352-00	IMPELLER IMPULSOR		1	
24	90280-04002	KEY, WOODRUFF CUNA WOODRUFF		1	
25	6CE-44323-01	OUTER PLATE, CARTRIDGE PLACA EXTERIOR DEL CARTUCHO		1	

FIG. 37 LOWER CASING & DRIVE 3

IMPULSOR E INFERIOR 3

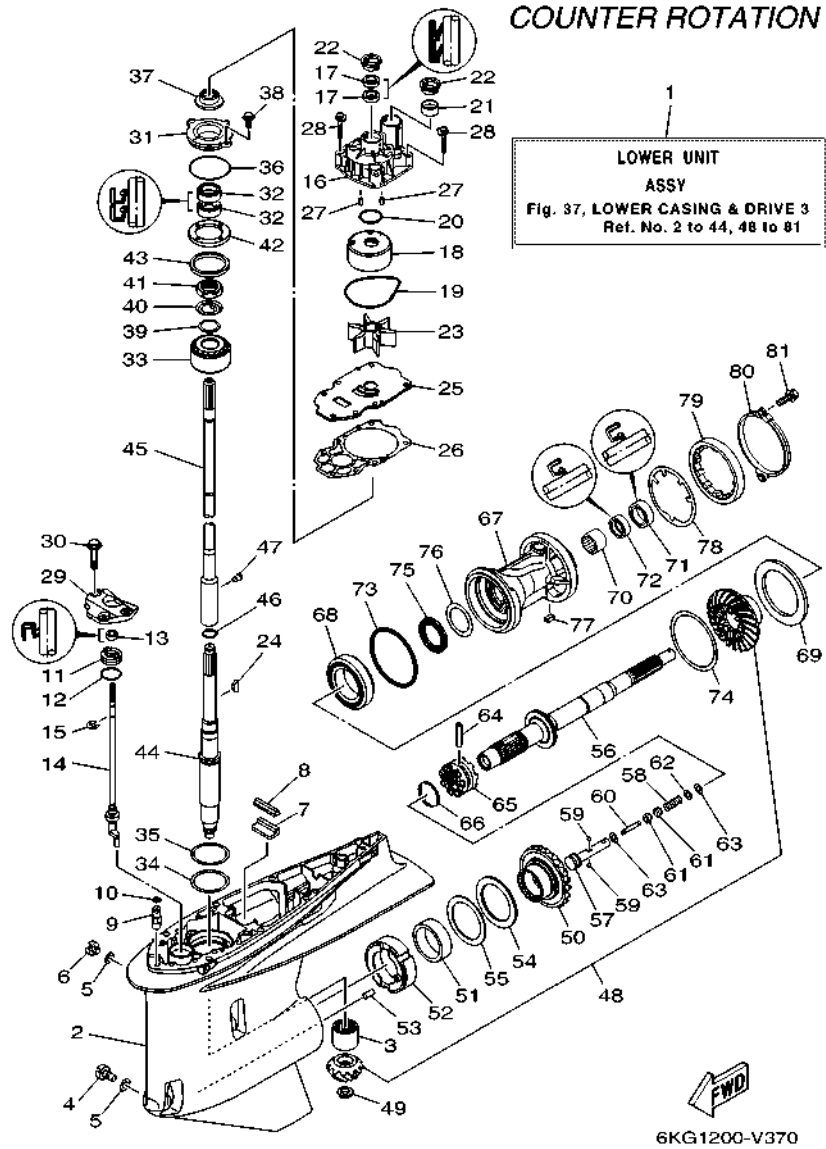

REF. NO.	PART NO. CODIGO N°	DESCRIPTION DESCRIPCION	6KF3	6KG3	REMARKS OBSERVACIONES
26	6CE-44315-00	GASKET, WATER PUMP EMPAQUE		1	
27	93606-12019	PIN, DOWEL PASADOR DE CLAVIJA		2	
28	90119-08191	BOLT, WITH WASHER TORNILLO CON ARANDELA		4	
29	6CB-44312-00	COVER, WATER PUMP HOUSING CUBIERTA CAJA BOMBA DE AGUA		1	
30	90119-08180	BOLT, WITH WASHER TORNILLO CON ARANDELA		3	
31	6AW-45335-00-CA	HOUSING, OIL SEAL CAJA DEL SELLO DE ACEITE		1	
32	93101-28019	OIL SEAL SELLO ACEITE		2	
33	93399-99962	BEARING COJINETE		1	
34	90201-68008	WASHER, PLATE ARANDELA PLANA		1	
35	6AW-45587-00	SHIM (T:0.10MM) LAINA (T:0.10MM)		1	UR UR
	6AW-45587-10	SHIM (T:0.12MM) LAINA (T:0.12MM)		1	UR UR
	6AW-45587-20	SHIM (T:0.15MM) LAINA (T:0.15MM)		1	UR UR
	6AW-45587-30	SHIM (T:0.18MM) LAINA (T:0.18MM)		1	UR UR
	6AW-45587-40	SHIM (T:0.30MM) LAINA (T:0.30MM)		1	UR UR
	6AW-45587-50	SHIM (T:0.40MM) LAINA (T:0.40MM)		1	UR UR
	6AW-45587-60	SHIM (T:0.50MM) LAINA (T:0.50MM)		1	UR UR
36	93210-69MG6	O-RING ANILLO O		1	
37	6KA-45344-00	COVER, OIL SEAL CUBIERTA SELLO ACEITE		1	
38	97E95-08520	BOLT, HEXAGON W/W DEEP RECESS TORNILLO HEXAGONAL CON RONDONA		2	
39	90201-301U7	WASHER, PLATE ARANDELA PLANA		1	
40	90214-30003	WASHER, CLAW ARANDELA DE POSICION		1	
41	90170-30M18	NUT TUERCA		1	
42	6AW-45244-00	NUT TUERCA		1	
43	6T5-45539-00	SPACER 2 ESPACIADOR 2		1	
44	6KA-45501-00	DRIVE SHAFT COMP. EJE DE MANDO COMPL.		1	
45	6KF-45802-00	INTERMEDI. DRIVE SHAFT COMP. INTERMEDIO EJE DE MANDO COMPL.		1	UR X(25.3") UR X(25.3")
	6KF-45802-10	INTERMEDI. DRIVE SHAFT COMP. INTERMEDIO EJE DE MANDO COMPL.		1	UR U(30.3") UR U(30.3")

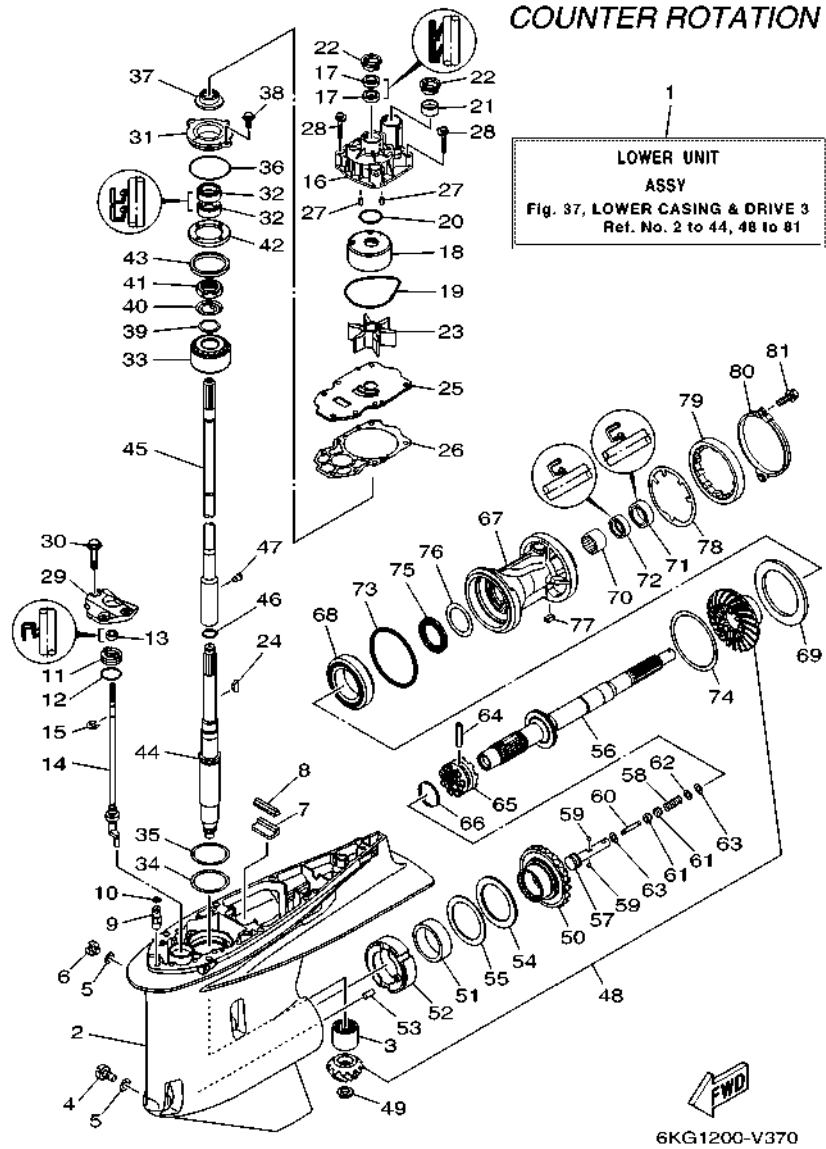

FIG. 37 LOWER CASING & DRIVE 3

IMPULSOR E INFERIOR 3

REF. NO.	PART NO. CODIGO N°	DESCRIPTION DESCRIPCION	6KFS	6KG3	REMARKS OBSERVACIONES
46	93210-22MF1	O-RING ANILLO O		1	
47	90149-05048	SCREW TORNILLO DE REGLAJE		1	
48	6KB-45550-00	GEAR SET JUEGO DE ENGRANAJE		1	
49	90179-16017	NUT TUERCA		1	
50	6KB-45560-00	GEAR 1 (21T) ENGRANAJE 1 (21T)		1	
51	93311-85894	BEARING COJINETE DE RODILLOS		1	
52	6CB-45824-00	ADAPTER ADAPTADOR		1	
53	93608-16M16	PIN, DOWEL PASADOR DE CLAVIJA		1	
54	93340-67011	BEARING COJINETES CON RODAMIENTOS		1	
55	6CB-45567-00	SHIM (T:2.00MM) LAINA (T:2.00MM)		1	UR UR
	6CB-45567-10	SHIM (T:2.03MM) LAINA (T:2.03MM)		1	UR UR
	6CB-45567-20	SHIM (T:2.06MM) LAINA (T:2.06MM)		1	UR UR
	6CB-45567-30	SHIM (T:2.09MM) LAINA (T:2.09MM)		1	UR UR
	6CB-45567-40	SHIM (T:2.12MM) LAINA (T:2.12MM)		1	UR UR
	6CB-45567-50	SHIM (T:2.15MM) LAINA (T:2.15MM)		1	UR UR
56	6KB-45611-00	SHAFT, PROPELLER EJE PROPUSOR		1	
57	6CB-45634-00	SLIDE, SHIFT DESILIZADOR, CAMBIO		1	
58	90501-10M77	SPRING, COMPRESSION RESORTE DE COMPRESION		1	
59	93501-04011	BALL BOLA		2	
60	6H1-45668-00	SHAFT, FREE 1 EJE 1		1	
61	61A-45635-00	PLUNGER, SHIFT EMBOLO DE CAMBIO		2	
62	90201-02M00	WASHER, PLATE ARANDELA PLANA		1	
63	90183-02M03	NUT, SPRING TUERCA DE RESORTE		2	
64	90250-08M07	PIN, STRAIGHT PASADOR CILINDRICO		1	
65	6KA-45631-00	CLUTCH, DOG EMBRAGUE DE GARRA		1	
66	6E5-45633-01	RING, CROSS PIN ANILLO DE PASADOR		1	
67	6CF-45332-01-CA	HOUSING, BEARING CAJA BALERO 2		1	

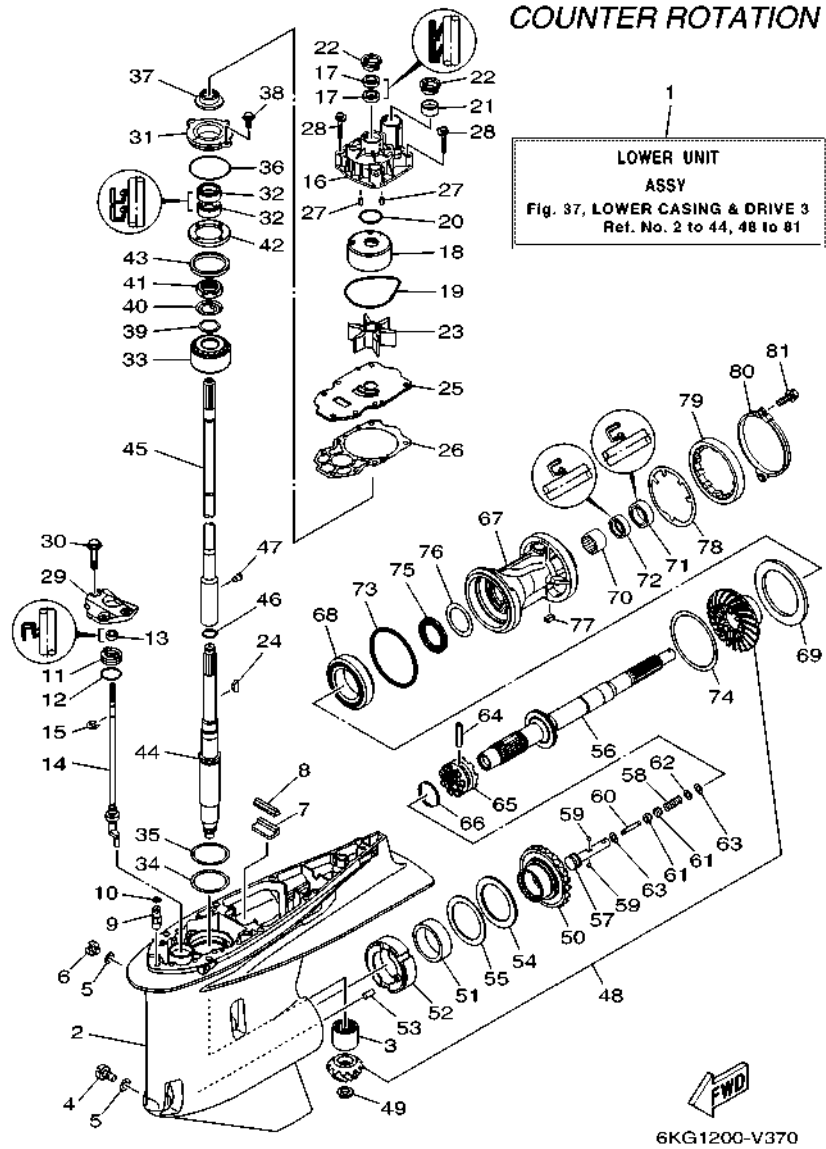

FIG. 37 LOWER CASING & DRIVE 3

IMPULSOR E INFERIOR 3

REF. NO.	PART NO. CODIGO N°	DESCRIPTION DESCRIPCION	6KFS	6KG3	REMARKS OBSERVACIONES
68	93332-00048	BEARING COJINETE		1	
69	6CF-45576-00	WASHER, THRUST 2 ARANDELA DE EMPUJE AXIAL 2		1	
70	93315-43061	BEARING COJINETE DE RODILLOS		1	
71	93101-30030	OIL SEAL SELLO ACEITE		1	
72	93101-30019	OIL SEAL SELLO ACEITE		1	
73	93211-02001	O-RING ANILLO O		1	
74	6CB-45577-00	SHIM (T:0.10MM) LAINA (T:0.10MM)		1	UR
	6CB-45577-10	SHIM (T:0.12MM) LAINA (T:0.12MM)		1	UR
	6CB-45577-20	SHIM (T:0.15MM) LAINA (T:0.15MM)		1	UR
	6CB-45577-30	SHIM (T:0.18MM) LAINA (T:0.18MM)		1	UR
	6CB-45577-40	SHIM (T:0.30MM) LAINA (T:0.30MM)		1	UR
	6CB-45577-50	SHIM (T:0.40MM) LAINA (T:0.40MM)		1	UR
	6CB-45577-60	SHIM (T:0.50MM) LAINA (T:0.50MM)		1	UR
75	93341-440U5	BEARING COJINETES CON RODAMIENTOS		1	
76	6K1-45578-01	SHIM (T:0.10MM) LAINA (T:0.10MM)		1	UR
	6K1-45578-10	SHIM (T:0.12MM) LAINA (T:0.12MM)		1	UR
	6K1-45578-20	SHIM (T:0.15MM) LAINA (T:0.15MM)		1	UR
	6K1-45578-30	SHIM (T:0.18MM) LAINA (T:0.18MM)		1	UR
	6K1-45578-40	SHIM (T:0.30MM) LAINA (T:0.30MM)		1	UR
	6K1-45578-50	SHIM (T:0.40MM) LAINA (T:0.40MM)		1	UR
	6K1-45578-60	SHIM (T:0.50MM) LAINA (T:0.50MM)		1	UR
77	90282-05008	KEY, STRAIGHT CHAVETA, RECTA		1	
78	6CB-45383-00	WASHER, CLAW ARANDELA DE UNA		1	
79	6CB-45384-00	NUT TUERCA		1	
80	6CE-45361-10	CAP, LOWER CASING FUNDA INFERIOR		1	
81	90105-08M61	BOLT, FLANGE TORNILLO		2	

FIG. 38 LOWER CASING & DRIVE 4

IMPULSOR E INFERIOR 4

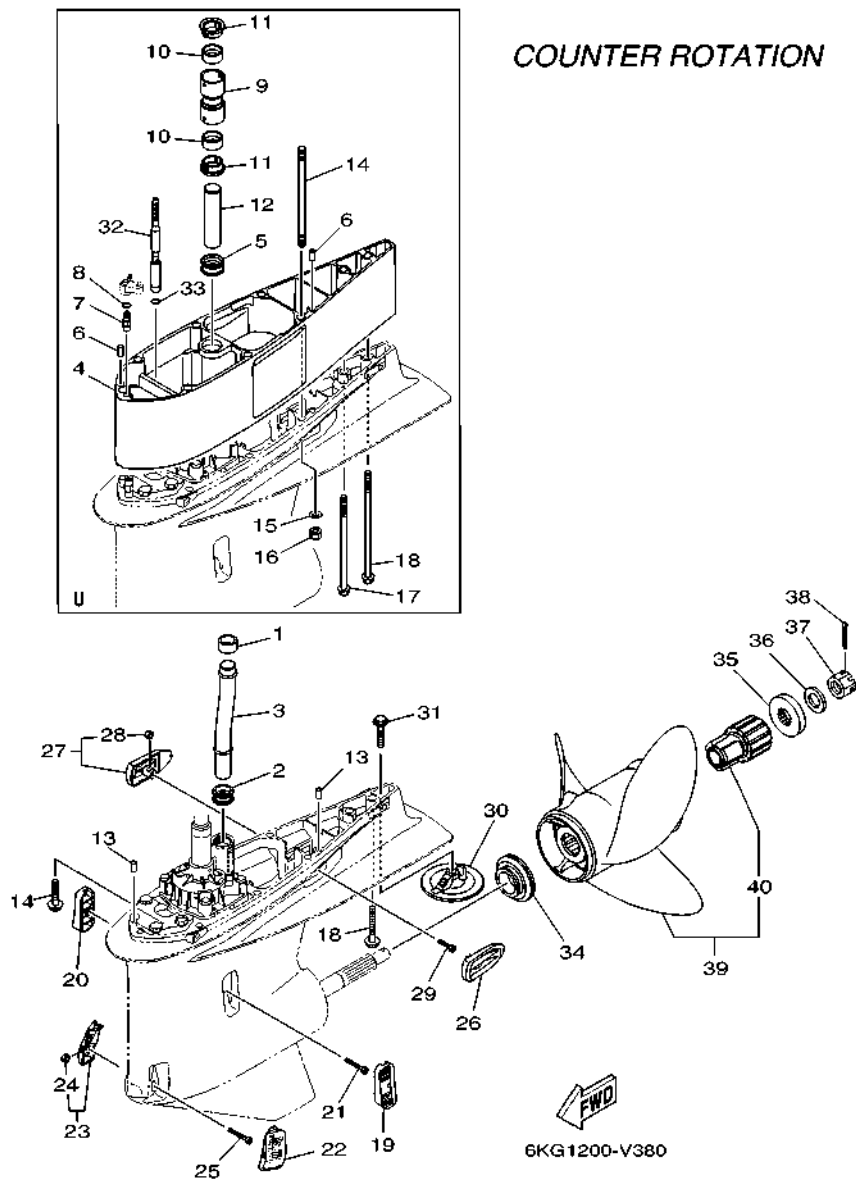

REF. NO.	PART NO. CODIGO N°	DESCRIPTION DESCRIPCION	6KFS	6KG3	REMARKS OBSERVACIONES
1	6AW-44365-01	DAMPER, WATER SEAL 1 HULE DE SELLO DE AGUA 1		1	
2	6AW-44366-01	DAMPER, WATER SEAL 2 GOMA DEL SELLO DE AGUA 2		1	
3	6CE-44361-00	TUBE, WATER 1 TUBO DE AGUA 1		1	
4	6CE-45211-10-8D	EXTENSION		1	UR GRAY, U(30.3") UR GRAY, U(30.3")
	6CE-45211-10-CE	EXTENSION		1	UR WHITE,U(30.3") UR WHITE,U(30.3")
5	6AW-44366-01	DAMPER, WATER SEAL 2 GOMA DEL SELLO DE AGUA 2		1	U(30.3") U(30.3")
6	93608-16M16	PIN, DOWEL PASADOR DE CLAVIJA		2	U(30.3") U(30.3")
7	63P-45378-00	NIPPLE, HOSE NIPLE MANGUERA		1	U(30.3") U(30.3")
8	93210-07003	O-RING ANILLO O		1	U(30.3") U(30.3")
9	6CE-44362-00	TUBE, WATER 2 TUBO DE AGUA 2		1	U(30.3") U(30.3")
10	6AW-44365-01	DAMPER, WATER SEAL 1 HULE DE SELLO DE AGUA 1		2	U(30.3") U(30.3")
11	6AW-44312-00	COVER, WATER PUMP HOUSING CUBIERTA CAJA BOMBA DE AGUA		2	U(30.3") U(30.3")
12	6AW-44363-00	TUBE, WATER 3 TUBO DE AGUA 3		1	U(30.3") U(30.3")
13	93608-16M16	PIN, DOWEL PASADOR DE CLAVIJA		2	
14	90119-10024	BOLT, WITH WASHER TORNILLO CON ARANDELA		7	UR X(25.3") UR X(25.3")
	90116-10067	BOLT, STUD ESPARRAGO		6	UR U(30.3") UR U(30.3")
15	92995-10600	WASHER ARANDELA		6	U(30.3") U(30.3")
16	95380-10600	NUT TUERCA		6	U(30.3") U(30.3")
17	90119-10009	BOLT, WITH WASHER TORNILLO CON ARANDELA		1	U(30.3") U(30.3")
18	97E75-10570	BOLT, HEXAGON W/W DEEP RECESS TORNILLO HEXAGONAL CON RONDONA		1	UR X(25.3") UR X(25.3")
	90119-10008	BOLT, WITH WASHER TORNILLO CON ARANDELA		1	UR U(30.3") UR U(30.3")
19	6KA-45214-00	COVER, WATER INLET 1 CUBIERTA, ENTRADA AGUA 1		1	
20	6KA-45215-00	COVER, WATER INLET 2 CUBIERTA, ENTRADA AGUA 2		1	
21	90110-05039	BOLT, HEXAGON SOCKET HEAD TORNILLO ALLEN		1	
22	6CE-45224-00	COVER, WATER INLET 3 CUBIERTA, ENTRADA AGUA 3		1	
23	6CE-45225-00	COVER, WATER INLET 4 CUBIERTA, ENTRADA AGUA 4		1	
24	90185-05002	.NUT, NYLON .TUERCA AUTOBLOCANTE		1	

FIG. 38 LOWER CASING & DRIVE 4

IMPULSOR E INFERIOR 4

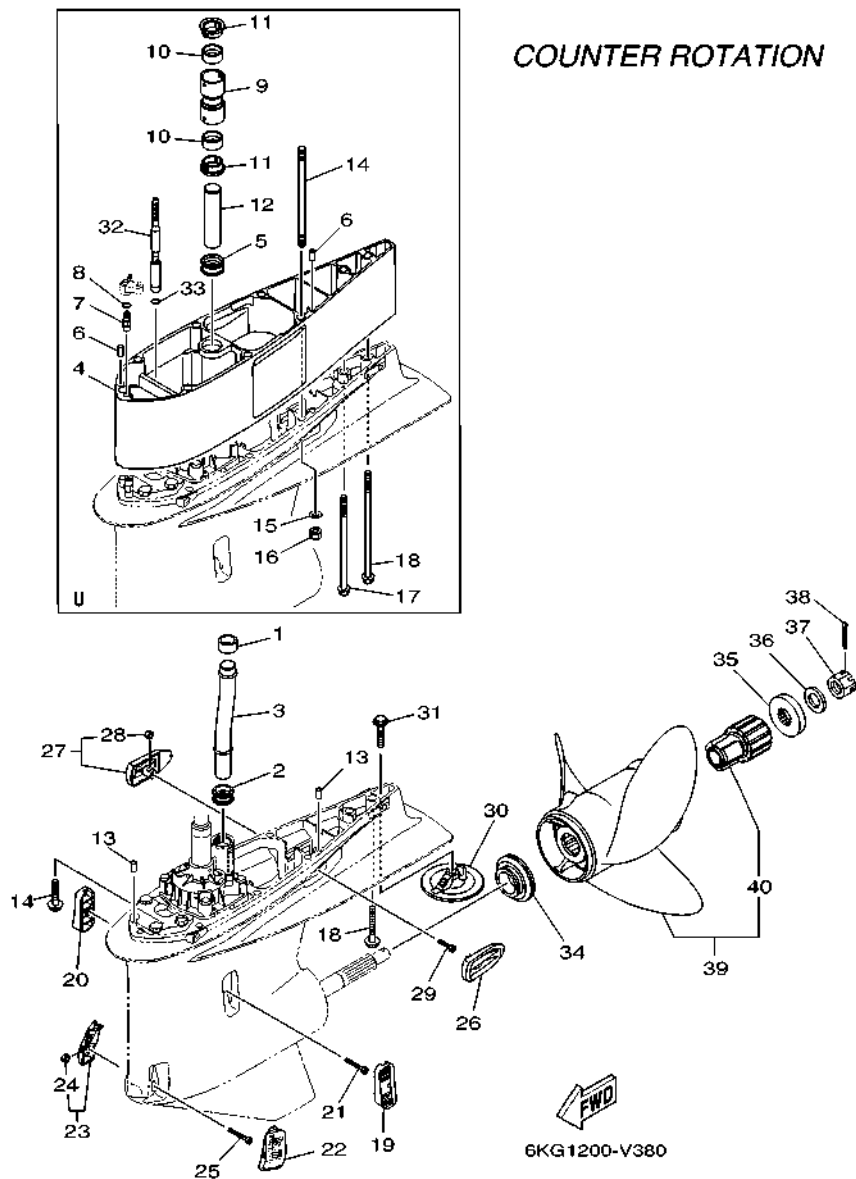

REF. NO.	PART NO. CODIGO N°	DESCRIPTION DESCRIPCION	6KFS	6KG3	REMARKS OBSERVACIONES
25	90110-05039	BOLT, HEXAGON SOCKET HEAD TORNILLO ALLEN		1	
26	6KA-45254-00	COVER, OUTLET 1 CUBIERTA, SALIDA 1		1	
27	6KA-45255-00	COVER, OUTLET 2 CUBIERTA, SALIDA 2		1	
28	90185-05002	.NUT, NYLON .TUERCA AUTOBLOCANTE		1	
29	91380-05020	BOLT PERNO		1	
30	6CE-45373-00	ANODE ANODO		1	
31	90105-10M00	BOLT, FLANGE TORNILLO		1	
32	6KA-44190-00	JT. SHIFT ROD COMP. JUNTA VARILLA EJE COMPL.		1	U(30.3") U(30.3")
33	93210-09165	O-RING ANILLO O		1	U(30.3") U(30.3")
34	69J-45987-00	SPACER 1 ESPACIADOR 1		1	
35	688-45997-01	SPACER 2 ESPACIADOR 2		1	
36	92990-18200	WASHER ARANDELA PLANA		1	
37	90171-18M04	NUT, CASTLE TUERCA ENTALLADA		1	
38	91490-40030	PIN, COTTER CHAVETA		1	
39	6KB-45970-00	PROPELLER (3X15-1/4"X18"-TL) PROPELA (3X15-1/4"X18"-TL)		1	UR UR
6KB-45972-00	PROPELLER (3X15-1/4"X19"-TL) PROPELA (3X15-1/4"X19"-TL)			1	UR UR
6KB-45974-00	PROPELLER (3X15"X20"-TL) PROPELA (3X15"X20"-TL)			1	UR UR
6KB-45976-00	PROPELLER (3X15"X21"-TL) PROPELA (3X15"X21"-TL)			1	UR UR
6CF-45970-20	PROPELLER (3X15-1/4"X19"-TL) PROPELA (3X15-1/4"X19"-TL)			1	UR FOR OTH UR FOR OTH
6CF-45978-20	PROPELLER (3X15-1/2"X17"-TL) PROPELA (3X15-1/2"X17"-TL)			1	UR FOR BRA UR FOR BRA
40	6CE-45C81-10	.DAMPER RUBBER, PROPELLER 1 .AMORTIGUADOR PROPELA 1		1	

FIG. 39 STEERING GUIDE ATTACHMENT 1

ADITAMENTO GUIA DE GOBIERNO 1

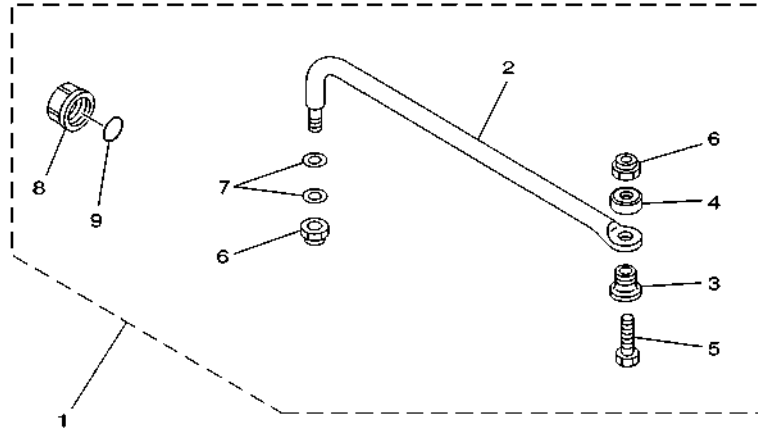

67H0100-9290

REF. NO.	PART NO. CODIGO N°	DESCRIPTION DESCRIPCION	6KFS	6KGS	REMARKS OBSERVACIONES
1	6E5-61350-02	STEERING GUIDE ATTACHMENT KIT ESTUCHE ADITAMENTO GUIA DE TIM	1		AP AP
2	6E5-61351-01	.ROD, STEERING LINK .VARILLA ESLABON DIRECCION	1		
3	90387-10M61	.COLLAR .ESPACIADOR	1		
4	90560-12M01	.SPACER .SEPARADOR	1		
5	6E5-61355-00	.BOLT .TORNILLO	1		
6	90185-09M01	.NUT, SELF-LOCKING .TUERCA AUTOBLOCANTE	2		
7	90201-10M20	.WASHER, PLATE .ARANDELA PLANA	2		
8	6E5-43145-01	.CAP, CLAMP BRACKET .TAPA	1		
9	93210-16275	.O-RING .ANILLO O	1		

FIG. 40 STEERING GUIDE ATTACHMENT 2

ADITAMENTO GUIA DE GOBIERNO 2

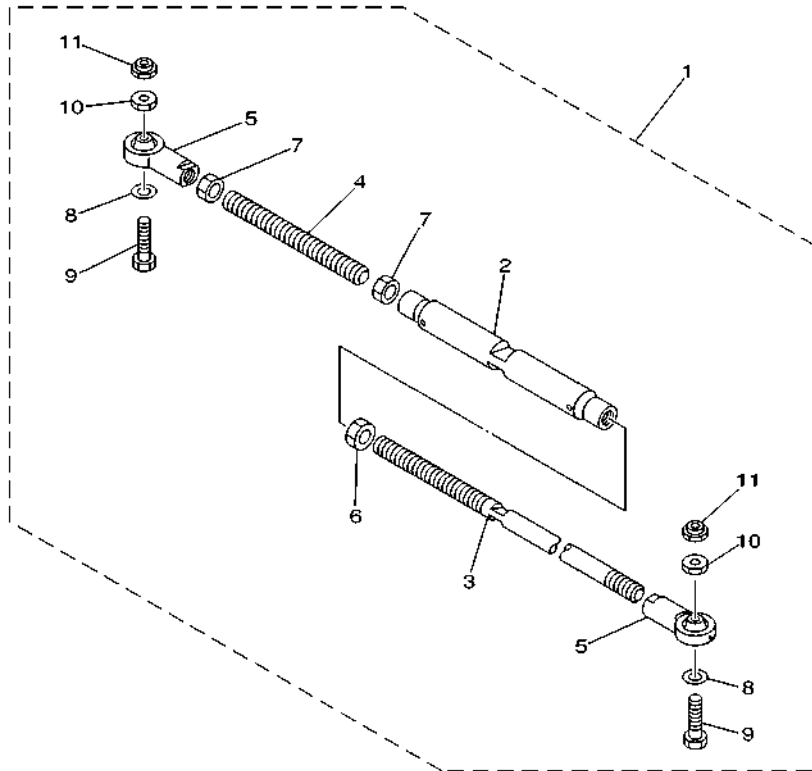

67H0100-0300

REF. NO.	PART NO. CODIGO N°	DESCRIPTION DESCRIPCION	6KFS	6KG3	REMARKS OBSERVACIONES
1	6E5-61301-01	TWIN KIT (L:600-800MM) KIT ADITAMENTO (L:600-800MM)		1	AP AP
2	6E5-61313-00	.ADJUSTER .AJUSTADOR		1	
3	6E5-61311-11	.TIE BAR .BARRA SEPARADORA		1	
4	6E5-61315-00	.TIE BAR .ROTOR DE BOMBA AGUA		1	
5	6E5-61303-01	.STEERING AXLE COMP. .OJO-DIRECCION COMPL.		2	
6	90170-14M06	.NUT .TUERCA		1	
7	95380-14700	.NUT .TUERCA		2	
8	90201-10M76	.WASHER, PLATE .ARANDELA PLANA		2	
9	90101-09M70	.BOLT .TORNILLO		2	
10	90170-09M05	.NUT .TUERCA		2	
11	90185-09M01	.NUT, SELF-LOCKING .TUERCA AUTOBLOCANTE		2	

SINGLE ENGINE

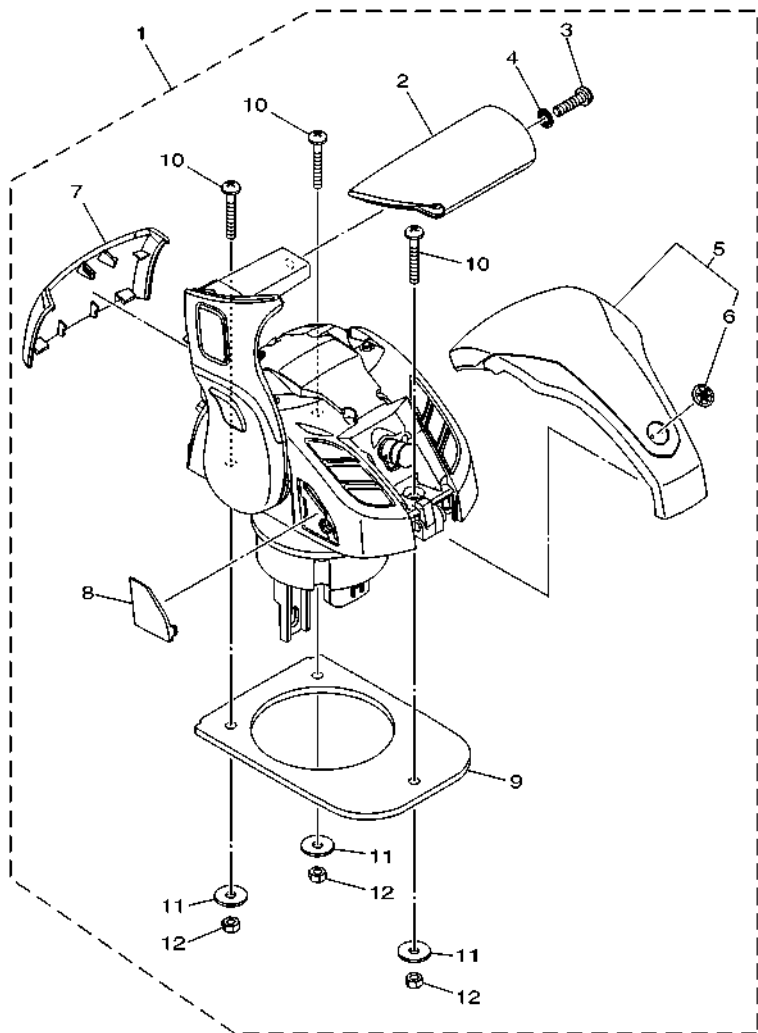

6X91100-U010

FIG. 41 DEC 1 (SINGLE)

DEC 1 (UNICO)

REF. NO.	PART NO. CODIGO N°	DESCRIPTION DESCRIPCION	6KFS	6KGS	REMARKS OBSERVACIONES
1	6X9-48A01-02	REMOTE CONTROL BOX ASSY 2 CONJ. DE CAJA CONTROL REMOTO 2	1		CAR (ASK TO MARINE DIV) CAR (ASK TO MARINE DIV)
2	6X9-4822A-00	.GRIP, LEVER SINGL .MANGO DE PALANCA SOLTERO	1		
3	6X9-48127-00	.SCREW 1 .TORNILLO 1	1		
4	92990-05300	.WASHER, INTERNAL TOOTH .ARANDELA PLANA	1		
5	6X9-48400-00	.COVER ASSY .CUBIERTA COMPL.	1		
6	6X9-42697-00	.TUNING FORK MARK .MARCA, YAMAHA	1		
7	6X9-4811C-00	.COVER, SINGLE .CUBIERTA DE SOLTERO	1		
8	6X9-48167-00	.PLUG .TAPON AGUJERO	1		
9	6X9-48176-00	.GROMMET .TOPON	1		
10	97780-50145	.SCREW, TAPPING .TORNILLO DE CABEZA DE CONO ACH	3		UR UR
	98580-05060	.SCREW, PAN HEAD .TORNILLO DE CABEZA CRUZADA	3		UR UR
11	704-48287-00	.WASHER .ARANDELA	3		
12	95380-05600	.NUT .TUERCA	3		

**DIGITAL ELECTRONIC CONTROL
(SINGLE ENGINE / MAIN STATION)**

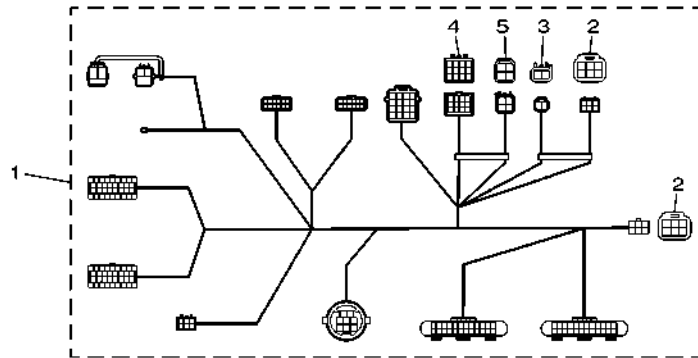
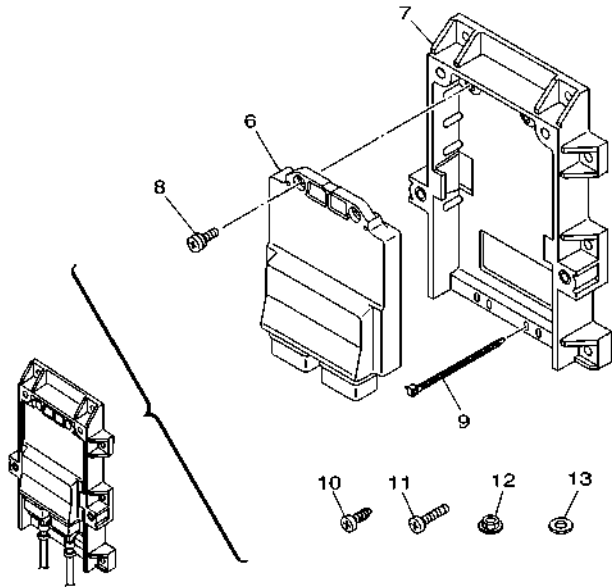

6LH1200-X430

FIG. 42 DEC 2 (SINGLE)

DEC 2 (UNICO)

REF. NO.	PART NO. CODIGO N°	DESCRIPTION DESCRIPCION	6KFS	6KGS	REMARKS OBSERVACIONES
1	6X9-82580-02	WIRE HARNESS ASSY 2 CONJUNTO DE CABLES 2	1		FOR CAR FOR CAR
2	6Y8-85371-01	.END OF LINE RESISTOR .RESISTENCIA DE FIN DE LINEA	2		
3	68V-82582-10	.CAP 1 (2P) .TAPA 1 (2P)	1		
4	6X9-82582-00	.CAP 1 (12P) .TAPA 1 (12P)	1		
5	6Y8-82582-11	.CAP 1 (4PIN) .TAPA 1 (4P)	1		
6	6X6-85590-42	CONTROL UNIT ASSY UNIDAD DE CONTROL COMPLETA	1		FOR CAR FOR CAR
7	6X9-48211-00	HOUSING,1 CAJA	1		FOR CAR FOR CAR
8	97607-05212	SCREW, WITH WASHER TORNILLO CAB CON PLANA C/ARAN	2		FOR CAR FOR CAR
9	90465-13M11	CLAMP BRIDA	2		FOR CAR FOR CAR
10	90167-06M00	SCREW, TAPPING TORNILLO DE ROSCA HEMBRA	8		FOR CAR FOR CAR
11	97880-06035	SCREW, PAN HEAD TORNILLO DE CABEZA CON PLANA	8		FOR CAR FOR CAR
12	95780-06300	NUT, FLANGE TUERCA	8		FOR CAR FOR CAR
13	90201-06M30	WASHER, PLATE ARANDELA PLANA	8		FOR CAR FOR CAR

TWIN ENGINE

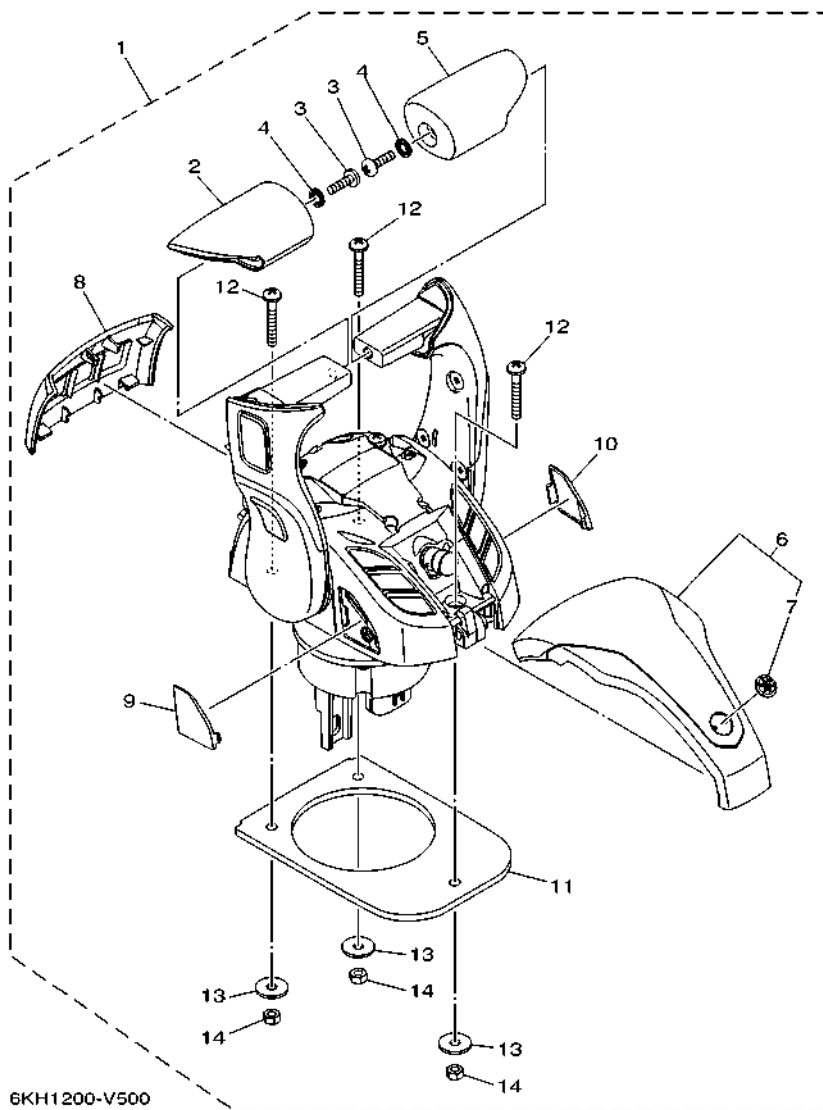

6KH1200-V500

FIG. 43 DEC 3 (TWIN)

DEC 3 (DOBLE)

REF. NO.	PART NO. CODIGO N°	DESCRIPTION DESCRIPCION	6KFS	6KG3		REMARKS OBSERVACIONES
1	6X9-48A02-02	REMOTE CONTROL BOX ASSY 3 CONJ. DE CAJA CONTROL REMOTO 3		1		EXCEPT NME (ASK TO MARINE DIV) EXCEPT NME (ASK TO MARINE DIV)
2	6X9-4822B-00	.GRIP, LEVER MULTI .MANGO DE PALANCA PLURAL		1		
3	6X9-48127-00	.SCREW 1 .TORNILLO 1		2		
4	92990-05300	.WASHER, INTERNAL TOOTH .ARANDELA PLANA		2		
5	6X9-48222-00	.GRIP, CONTROL LEVER .MANGO DE PALANCA CONTROL		1		
6	6X9-48400-00	.COVER ASSY .CUBIERTA COMPL.		1		
7	6X9-42697-00	..TUNING FORK MARK ..MARCA, YAMAHA		1		
8	6X9-48119-00	.COVER .CUBIERTA		1		
9	6X9-48167-00	.PLUG .TAPON AGUJERO		1		
10	6X9-48168-00	.PLUG 2 .TAPON AGUJERO 2		1		
11	6X9-48176-00	.GROMMET .TOPON		1		
12	97780-50145	.SCREW, TAPPING .TORNILLO DE CABEZA DE CONO ACH		3		UR
	98580-05060	.SCREW, PAN HEAD .TORNILLO DE CABEZA CRUZADA		3		UR
13	704-48287-00	.WASHER .ARANDELA		3		UR
14	95380-05600	.NUT .TUERCA		3		

**DIGITAL ELECTRONIC CONTROL
(TWIN ENGINE / MAIN STATION)**

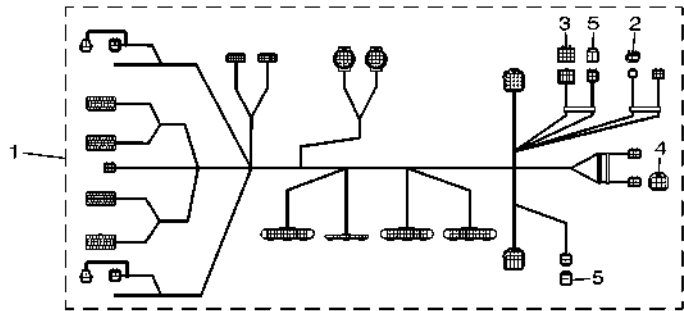
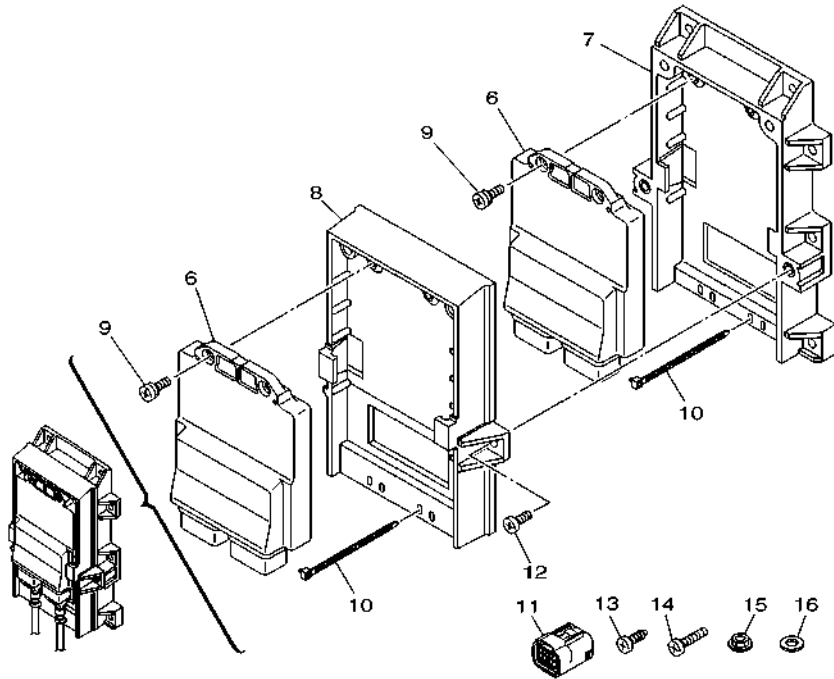

6LH1200-X470

FIG. 44 DEC 4 (TWIN)

DEC 4 (DOBLE)

REF. NO.	PART NO. CODIGO N°	DESCRIPTION DESCRIPCION	6KFS	6KG3	REMARKS OBSERVACIONES
1	6X9-82580-42	WIRE HARNESS ASSY 2 CONJUNTO DE CABLES 2		1	EXCEPT NME EXCEPT NME
2	68V-82582-10	.CAP 1 (2P) .TAPA 1 (2P)		1	
3	6X9-82582-00	.CAP 1 (12P) .TAPA 1 (12P)		1	
4	6X9-82582-10	.CAP 1 (6P) .TAPA 1 (6P)		1	
5	6Y8-82582-11	.CAP 1 (4PIN) .TAPA 1 (4P)		2	
6	6X6-85590-42	CONTROL UNIT ASSY UNIDAD DE CONTROL COMPLETA		2	EXCEPT NME EXCEPT NME
7	6X9-48211-00	HOUSING,1 CAJA		1	EXCEPT NME EXCEPT NME
8	6X9-4821A-00	HOUSING, 2 CAJA 2		1	EXCEPT NME EXCEPT NME
9	97607-05212	SCREW, WITH WASHER TORNILLO CAB CON PLANA C/ARAN		4	EXCEPT NME EXCEPT NME
10	90465-13M11	CLAMP BRIDA		4	EXCEPT NME EXCEPT NME
11	6Y8-85371-01	END OF LINE RESISTOR RESISTENCIA DE FIN DE LINEA		2	EXCEPT NME EXCEPT NME
12	98507-06016	SCREW, PAN HEAD TORNILLO DE CABEZA CON PLANA		4	EXCEPT NME EXCEPT NME
13	90167-06M00	SCREW, TAPPING TORNILLO DE ROSCA HEMBRA		8	EXCEPT NME EXCEPT NME
14	97880-06035	SCREW, PAN HEAD TORNILLO DE CABEZA CON PLANA		8	EXCEPT NME EXCEPT NME
15	95780-06300	NUT, FLANGE TUERCA		8	EXCEPT NME EXCEPT NME
16	90201-06M30	WASHER, PLATE ARANDELA PLANA		8	EXCEPT NME EXCEPT NME

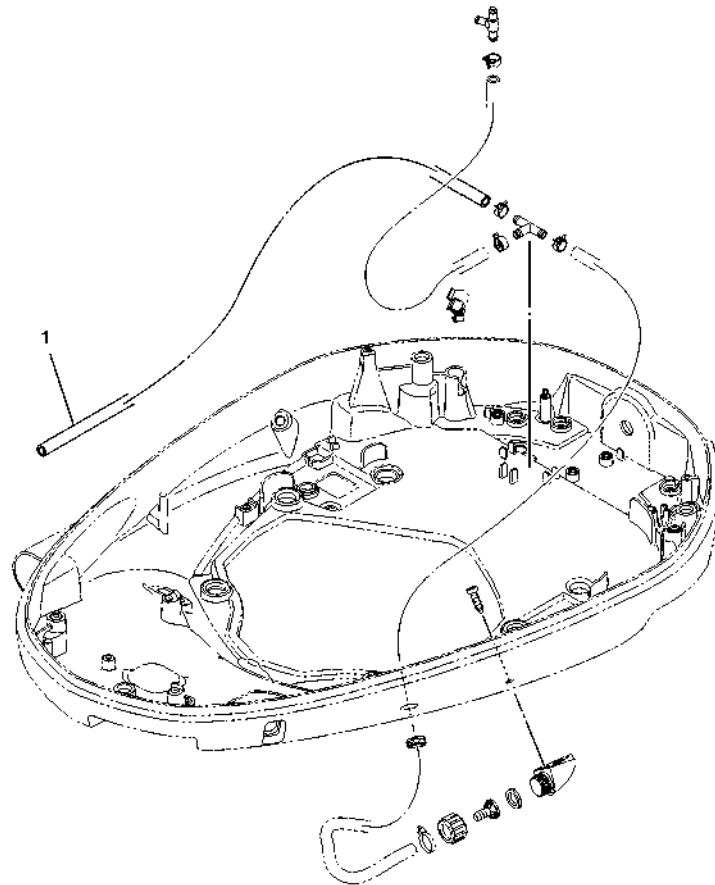

 6KA1 100-V410

FIG. 45 OPTIONAL PARTS 1

PARTES OPCIONALES 1

REF. NO.	PART NO. CODIGO N°	DESCRIPTION DESCRIPCION	6KFS	6KGS	REMARKS OBSERVACIONES
1	6KA-44385-00	HOSE, WATER 1 TUBO DE AGUA 1	1	1	

FIG. 46 OPTIONAL PARTS 2

PARTES OPCIONALES 2

REF. NO.	PART NO. CODIGO N°	DESCRIPTION DESCRIPCION	6KFS	6KGS		REMARKS OBSERVACIONES
1	6KA-42723-10-8D	COVER, BOTTOM CUBIERTA INFERIOR	1	1		UR GRAY
	6KA-42723-10-CE	COVER, BOTTOM CUBIERTA INFERIOR	1	1		UR WHITE
2	90480-20006	GROMMET TAPON	1	1		
3	6KA-83720-00	L.E.D ASS'Y L.E.D COMPLETO	1	1		
4	6KA-84516-00	COVER, TAILLIGHT CUBIERTA DE LUZ DE COLA	1	1		
5	97780-40112	SCREW, OVAL HEAD TAPPING TORNILLO DE CABEZA DE CONO ACH	4	4		

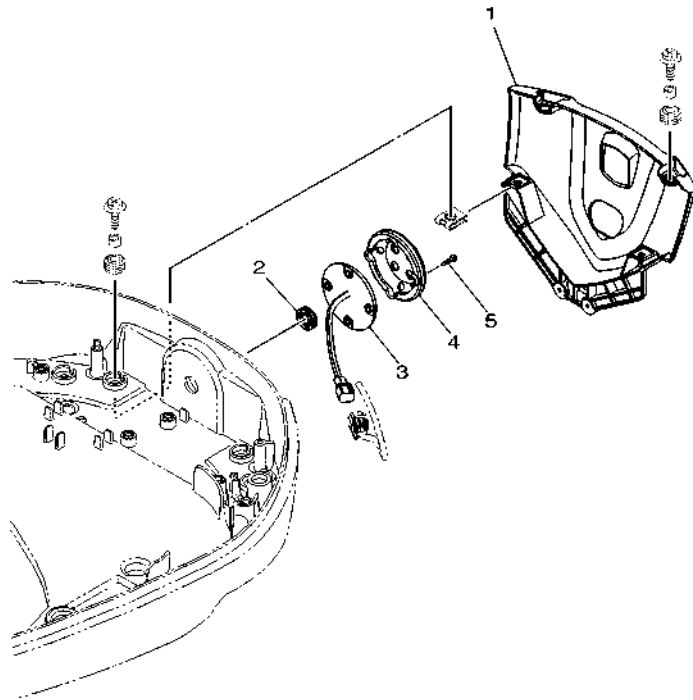

6KA1 100-V420

FIG. 47 OPTIONAL PARTS 3

PARTES OPCIONALES 3

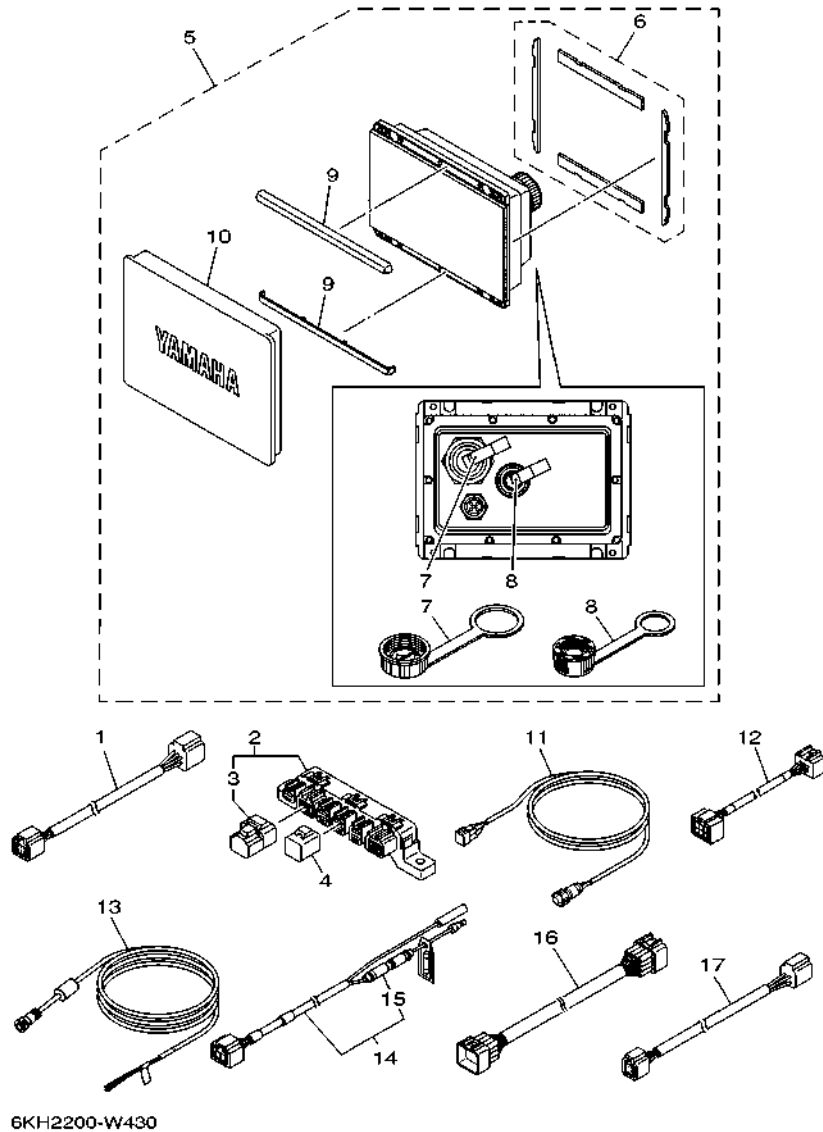

REF. NO.	PART NO. CODIGO N°	DESCRIPTION DESCRIPCION	6KFS	6KGS	REMARKS OBSERVACIONES
1	6Y8-82553-01	1FT MAIN BUS CABLE	1		FOR CAR,BRA FOR CAR,BRA FOR OTH FOR OTH
	6Y8-82553-41	30FT MAIN BUS CABLE	1		
2	6Y8-81920-01	MULTI HUB ASSY	1		
3	6Y8-85371-01	TERMINAL COMPLETE	1		
4	6Y8-82582-11	.END OF LINE RESISTOR .RESISTENCIA DE FIN DE LINEA	1		
5	6Y8-82582-11	CAP 1 (4PIN) TAPA 1 (4P)	2		
5	6YM-83710-16	CL5 DISPLAY CL5 PANTALLA	1		WITHOUT WI-FI WITHOUT WI-FI
6	6YM-22480-00	.SEAL ASSY .JUEGO DE JUNTO	1		
7	6YM-83956-00	.CAP 1 .TAPA 1	1		
8	6YD-83957-00	.CAP 2 .TAPA 2	1		
9	6YM-83512-00	.RIM .ANILLO	2		
10	6YM-87278-00	.COVER, METER .CUBIERTA DE MEDIDOR	1		
11	6YM-83553-00	CONVERSION HARNESS CABLE CONDUCTOR	1		
12	6Y9-83553-00	WIRE, LEAD CABLE CONDUCTOR	1		
13	6YD-8356N-00	WIRE, LEAD CABLE CONDUCTOR	1		
14	6Y8-83553-02	8FT POWER WIRE CABLE CONDUCTOR	1		
15	6G1-82151-01	.FUSE (10A) .FUSIBLE (10A)	1		
16	6X6-8258A-31	EXTENSION, WIRE HARNESS (10M) EXTENSION, CABLES (10M)	1		FOR BRA,OTH FOR BRA,OTH FOR CAR,BRA FOR CAR,BRA FOR OTH FOR OTH
17	6Y8-82521-31	6FT PIGTAIL BUS CABLE CONDUCTOR	1		
	6Y8-82521-51	12FT PIGTAIL BUS CABLE CONDUCTOR	1		

FIG. 48 OPTIONAL PARTS 4

PARTES OPCIONALES 4

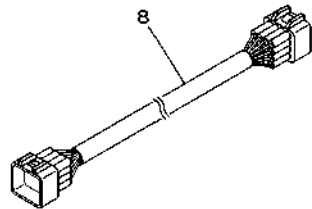
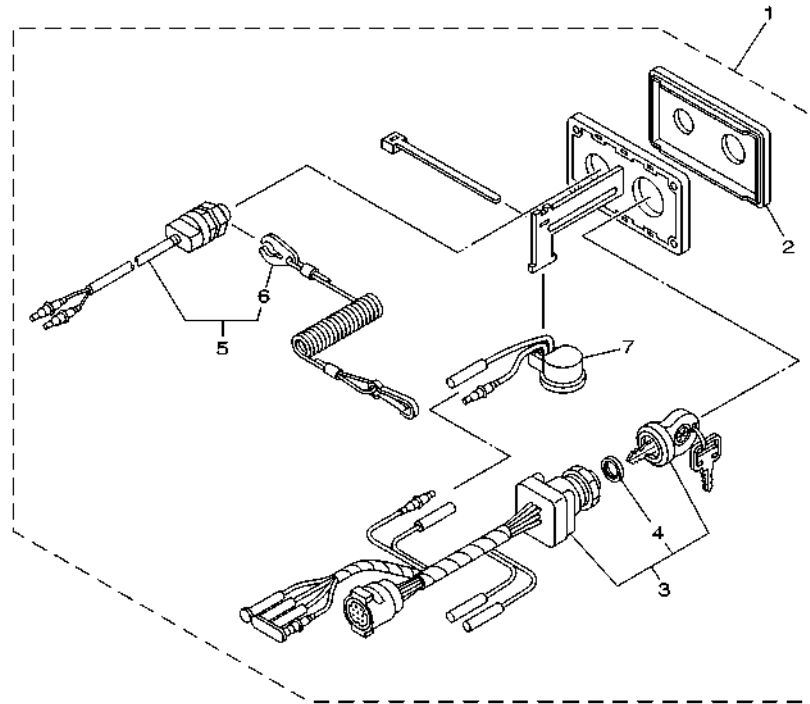

6DV4200-Q440

REF. NO.	PART NO. CODIGO N°	DESCRIPTION DESCRIPCION	6KFS	6KGS		REMARKS OBSERVACIONES
1	6X6-82570-34	PANEL SWITCH ASSY INTERRUPTOR DE PANEL COMPL.	1			FOR CAR FOR CAR
2	6X6-82571-00	.PANEL, SWITCH .PANEL DE INTERRUPTOR	1			
3	6X6-82510-02	.MAIN SWITCH ASSY .CONJUNTO DE LLAVE IGNICION	1			
4	703-82532-00	..CAP ..TAPA	1			
5	688-82575-12	.ENGINE STOP SWITCH ASSY .INTERRUPTOR DE PARADA COMPL.	1			
6	682-82556-00	..LANYARD, STOP SWITCH ..CORDON DE INTERRUPTOR PARADA	1			
7	703-83383-A0	.BUZZER .ZUMBADOR	1			
8	6X6-8258A-31	EXTENSION, WIRE HARNESS (10M) EXTENSION, CABLES (10M)	1			FOR CAR FOR CAR

FIG. 49 OPTIONAL PARTS 5

PARTES OPCIONLES 5

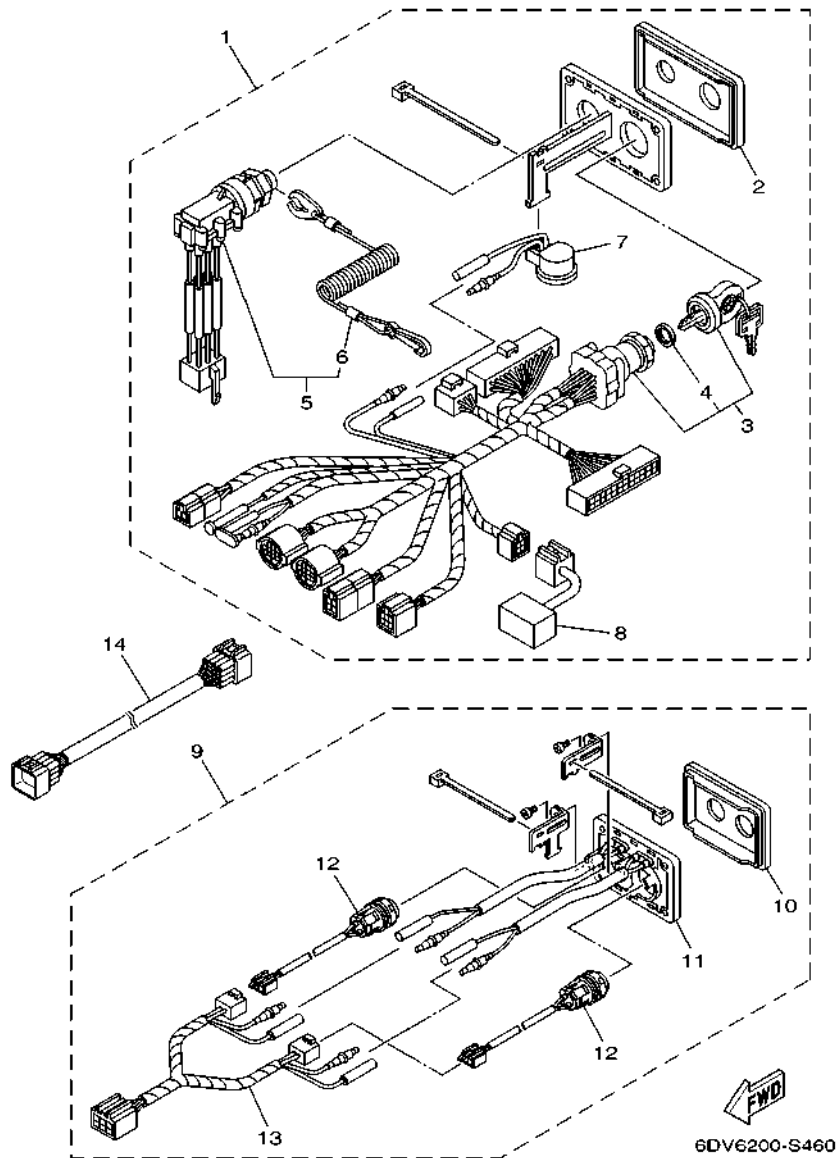

REF. NO.	PART NO. CODIGO N°	DESCRIPTION DESCRIPCION	6KFS	6KG3	REMARKS OBSERVACIONES
1	6X6-82570-41	PANEL SWITCH ASSY INTERRUPTOR DE PANEL COMPL.		1	EXCEPT FOR NME EXCEPT FOR NME
2	6X6-82571-10	.PANEL, SWITCH .PANEL DE INTERRUPTOR		1	
3	6X6-82510-11	.MAIN SWITCH ASSY .CONJUNTO DE LLAVE IGNICION		1	
4	703-82532-00	..CAP ..TAPA		1	
5	6X6-82575-10	.ENGINE STOP SWITCH ASSY .INTERRUPTOR DE PARADA COMPL.		1	
6	682-82556-00	..LANYARD, STOP SWITCH ..CORDON DE INTERRUPTOR PARADA		1	
7	703-83383-A0	.BUZZER .ZUMBADOR		1	
8	6X6-81980-00	.DIODE ASSY .CONJUNTO DIODO		1	
9	6X6-82570-60	PANEL SWITCH ASSY INTERRUPTOR DE PANEL COMPL.		1	EXCEPT FOR NME EXCEPT FOR NME
10	6X6-82571-20	.PANEL, SWITCH .PANEL DE INTERRUPTOR		1	
11	6X6-83720-00	.L.E.D ASS'Y .L.E.D COMPLETO		1	
12	6X6-8259E-20	.SWITCH ASSY .INTERRUPTOR COMPL		2	
13	6X6-82716-00	.CORD SWITCH .CABLE INTERRUPTOR		1	
14	6X6-8258A-41	EXTENSION, WIRE HARNESS (12M) EXTENSION, CABLES (12M)		1	EXCEPT FOR NME EXCEPT FOR NME

FIG. 50 OPTIONAL PARTS 6

PARTES OPCIONALES 6

REF. NO.	PART NO. CODIGO N°	DESCRIPTION DESCRIPCION	6KF3	6KG3			REMARKS OBSERVACIONES
1	63P-8A4L0-07	SENSOR, MODULE SENSOR COMP.	1	1			FOR CAR FOR CAR
2	6AW-8366B-10	.SENSOR, WATER PRESSURE .SENSOR DE PRESION AGUA	1	1			
3	63P-8366C-00	.ADAPTOR, INPUT .CONECTOR BANJO 2	1	1			
4	90430-14115	.GASKET .JUNTA	1	1			

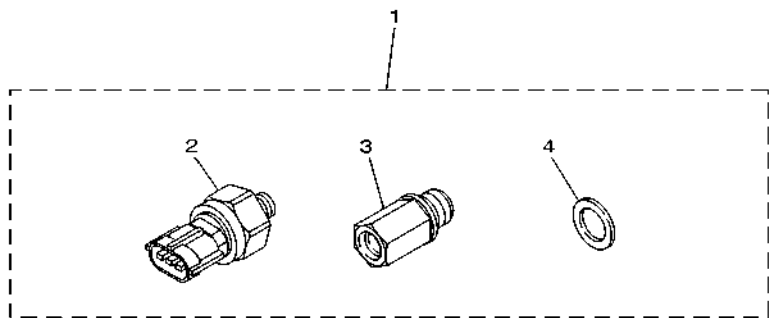

6KF1200-V490

FIG. 51 OPTIONAL PARTS 7

PARTES OPCIONALES 7

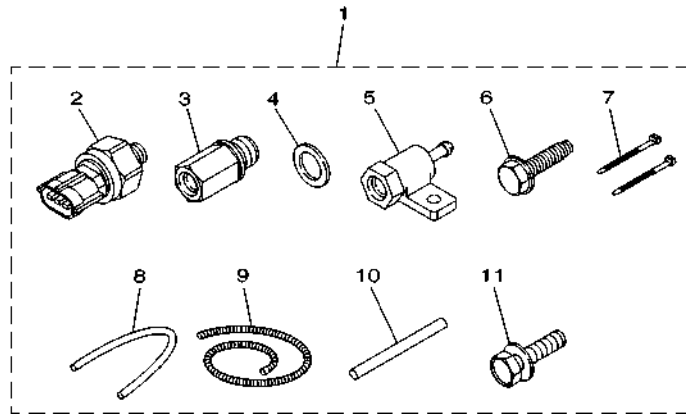

REF. NO.	PART NO. CODIGO N°	DESCRIPTION DESCRIPCION	6KFS	6KG3	REMARKS OBSERVACIONES
1	63P-8A4L2-07	SENSOR, MODULE 2 SENSOR COMP. 2	1		FOR BRA FOR BRA
2	6AW-8366B-10	.SENSOR, WATER PRESSURE .SENSOR DE PRESION AGUA	2		
3	63P-8366C-00	.ADAPTOR, INPUT .CONECTOR BANJO 2	1		
4	90430-14115	.GASKET .JUNTA	1		
5	60V-8366D-00	.ADAPTOR, INPUT .CONECTOR BANJO 3	1		
6	90109-06M81	.BOLT .PERNO	1		
7	90465-11M10	.CLAMP .BRIDA	2		
8	90445-07017	.HOSE (L: 550MM) .TUBO (L: 550MM)	1		
9	90447-07013	.HOSE, COVER (L: 700MM) .MANGUERA DE CUBIERTA (L:700MM)	1		
10	60V-42629-01	.SEAL .SELLO 2	1		
11	97E95-06516	.BOLT, HEXAGON W/W DEEP RECESS .TORNILLO HEXAGONAL CON RONDONA	1		

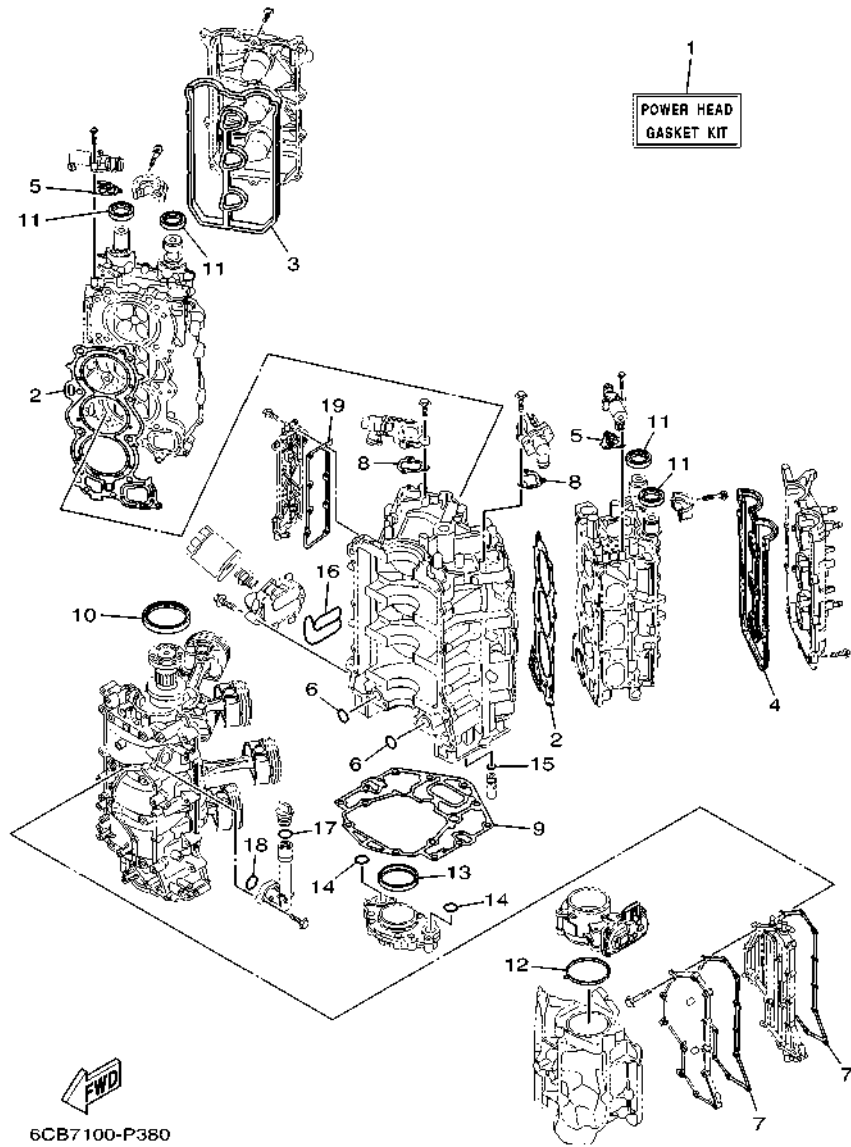

6CB7100-P380

FIG. 52 REPAIR KIT 1

ESTUCHE REPARATION 1

REF. NO.	PART NO. CODIGO N°	DESCRIPTION DESCRIPCION	6KFS	6KGS		REMARKS OBSERVACIONES
1	6CB-W0001-04	POWER HEAD GASKET KIT JUEGO DE EMPAQUE DE MOTOR	1	1		
2	6CB-11181-00	.GASKET, CYLINDER HEAD 1 .JUNTA, DE CULATA 1	2	2		
3	6CB-11193-00	.GASKET, HEAD COVER 1 .EMPAQUE	1	1		
4	6CB-11194-00	.GASKET, HEAD COVER 2 .EMPAQUE DE TAPA DE CULATA 2	1	1		
5	6CB-1242F-00	.GASKET, FILTER .EMPAQUE DE FILTRO	2	2		
6	93210-26658	.O-RING .ANILLO O	2	2		
7	6CB-15451-01	.GASKET, CRANKCASE COVER 1 .EMPAQ DE CUBIERTA DE CARTER	2	2		
8	6CB-12427-11	.GASKET, HOUSING COVER 1 .EMPAQUE DE TAPA	2	2		
9	6KA-11351-00	.GASKET, CYLINDER .JUNTA, DE CILINDRO	1	1		
10	93102-85008	.OIL SEAL .SELLO ACEITE	1	1		
11	93102-38008	.OIL SEAL .SELLO ACEITE	4	4		
12	6CB-13556-00	.GASKET, MANIFOLD .EMPAQUE	1	1		
13	6CB-11355-00	.SEAL, CYLINDER 1 .RETEN ACEITE CILINDRO 1	1	1		
14	93210-26658	.O-RING .ANILLO O	2	2		
15	6CB-13473-00	.O-RING .ANILLO O	1	1		
16	6CB-13477-00	.GASKET .EMPAQUE	1	1		
17	93210-24M79	.O-RING .ANILLO O	1	1		
18	93210-27370	.O-RING .ANILLO O	1	1		
19	6CB-1131B-00	.GASKET, COVER .EMPAQUE DE CUBIERTA	1	1		

FIG. 53 REPAIR KIT 2

ESTUCHE REPARATION 2

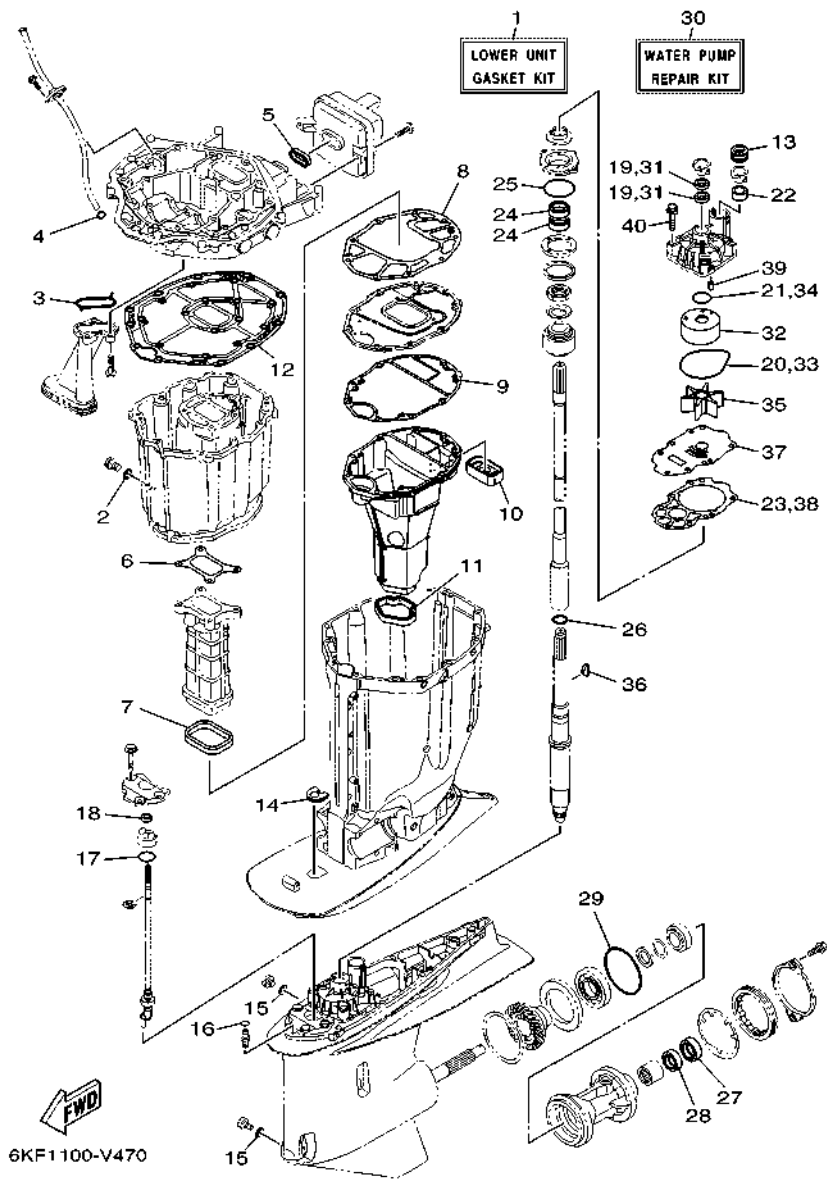

REF. NO.	PART NO. CODIGO N°	DESCRIPTION DESCRIPCION	6KF3	6KG3	REMARKS OBSERVACIONES
1	6KA-W0001-20	LOWER UNIT GASKET KIT JUEGO DE EMPAQUE UNIDAD INFER.	1	1	
2	90430-14M09	.GASKET .JUNTA	1	1	
3	6AW-13415-00	.SEAL, OIL STRAINER .SELLO COLADOR ACEITE	1	1	
4	93210-19MJ3	.O-RING .ANILLO O	1	1	
5	6CB-14755-01	.GASKET, SILENCER .EMPAQUE DE SILENCIADOR	1	1	
6	6CB-41134-00	.GASKET, EXHAUST MANIFOLD .EMPAQUE	1	1	
7	6CB-41138-00	.SEAL, EXT. 1 .SELLO, ESCAPE 1	1	1	
8	6CB-41135-00	.GASKET, EXHAUST MANIFOLD .EMPAQUE	1	1	
9	6CE-41136-00	.GASKET, EXHAUST MANIFOLD 4 .EMPAQUE	1	1	
10	6CE-45127-00	.SEAL .SELLO DE GOMA	1	1	
11	6CE-45123-00	.GASKET, MUFFLER .EMPAQUE SILENCIADOR	1	1	
12	6CB-45113-10	.GASKET, UPPER CASING .EMPAQUE	1	1	
13	6AW-44366-01	.DAMPER, WATER SEAL 2 .GOMA DEL SELLO DE AGUA 2	1	1	
14	6KA-44521-00	.SEAL .SELLO DE GOMA	1	1	
15	90430-08003	.GASKET .JUNTA	2	2	
16	93210-07003	.O-RING .ANILLO O	1	1	
17	93210-33M49	.O-RING .ANILLO O	1	1	
18	93106-10001	.OIL SEAL .SELLO ACEITE	1	1	
19	93104-22M07	.OIL SEAL .SELLO ACEITE	2	2	
20	93210-94003	.O-RING .ANILLO O	1	1	
21	93210-37160	.O-RING .ANILLO O	1	1	
22	6AW-44365-01	.DAMPER, WATER SEAL 1 .HULE DE SELLO DE AGUA 1	1	1	
23	6CE-44315-00	.GASKET, WATER PUMP .EMPAQUE	1	1	
24	93101-28019	.OIL SEAL .SELLO ACEITE	2	2	
25	93210-69MG6	.O-RING .ANILLO O	1	1	
26	93210-22MF1	.O-RING .ANILLO O	1	1	
27	93101-30030	.OIL SEAL .SELLO ACEITE	1	1	

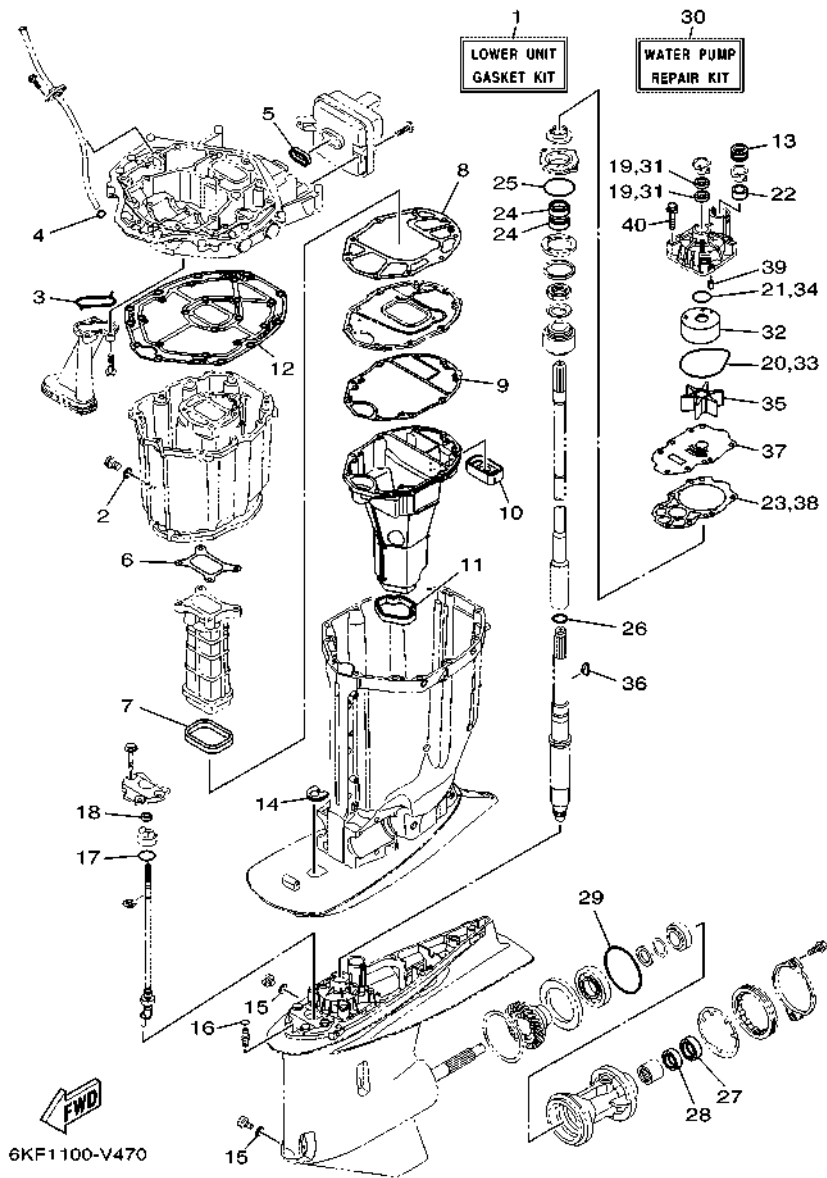

FIG. 53 REPAIR KIT 2

ESTUCHE REPARATION 2

REF. NO.	PART NO. CODIGO N°	DESCRIPTION DESCRIPCION	6KF3	6KG3	REMARKS OBSERVACIONES
28	93101-30019	.OIL SEAL .SELLO ACEITE	1	1	
29	93211-02001	.O-RING .ANILLO O	1	1	
30	6CE-W0078-02	WATER PUMP REPAIR KIT ESTUCHE REPARACION BOMBA AGUA	1	1	
31	93104-22M07	.OIL SEAL .SELLO ACEITE	2	2	
32	6AW-44322-00	.INSERT, CARTRIDGE .CARTUCHO	1	1	
33	93210-94003	.O-RING .ANILLO O	1	1	
34	93210-37160	.O-RING .ANILLO O	1	1	
35	6CE-44352-00	.IMPELLER .IMPULSOR	1	1	
36	90280-04002	.KEY, WOODRUFF .CUNA WOODRUFF	1	1	
37	6CE-44323-01	.OUTER PLATE, CARTRIDGE .PLACA EXTERIOR DEL CARTUCHO	1	1	
38	6CE-44315-00	.GASKET, WATER PUMP .EMPAQUE	1	1	
39	93606-12019	.PIN, DOWEL .PASADOR DE CLAVIJA	2	2	
40	90119-08191	.BOLT, WITH WASHER .TORNILLO CON ARANDELA	4	4	

NUMERICAL INDEX
INDICE NUMERICO

PART NO. CODIGO N°	REF. NO.	PART NO. CODIGO N°	REF. NO.	PART NO. CODIGO N°	REF. NO.	PART NO. CODIGO N°	REF. NO.	PART NO. CODIGO N°	REF. NO.	PART NO. CODIGO N°	REF. NO.
6KA-11000-00	3 - 1	6CB-11427-03	4 - 8	6P2-12615-00	8 - 25	6AW-13761-01	12 - 2	6CE-14872-00	18 - 28	6CE-24377-00	18 - 17
6CE-11110-12-9S	5 - 2	6CB-11478-00	4 - 2	6P2-12623-00	8 - 20		12 - 6	6CB-14984-00	1 - 12	6AW-24377-01	15 - 4
6CE-11120-12-9S	5 - 12	6CB-1149A-00	6 - 10		8 - 23	6AW-13781-00	13 - 34		13 - 31	688-24378-00	7 - 2
6S5-11133-10	5 - 3	6KA-11567-00	8 - 17	6CB-12645-01	8 - 19	6CB-13782-00	10 - 16	6CB-14985-00	13 - 25		10 - 21
	5 - 13	6CB-11590-03	8 - 28	6CB-1264A-01	8 - 22	6AW-13784-00	13 - 35	6EK-14989-00	10 - 30		10 - 35
6CB-11181-00	5 - 25	6CB-11603-00	4 - 12	6P2-12663-00	8 - 21	6KA-13898-00	11 - 7	6CE-15100-10	3 - 2		18 - 30
	52 - 2	6CE-11631-02	4 - 11		8 - 24	6CB-13898-11	11 - 8	6AW-15142-00	5 - 38	6CE-24378-00	7 - 13
6CB-11191-02	5 - 30	6CB-11633-00	4 - 13	6CB-13016-00	1 - 10	6CB-13906-01	13 - 8	6CB-15142-00	6 - 8	6E5-24378-00	14 - 8
6CB-11192-02	5 - 34	63P-11654-10	4 - 10		13 - 5	6CB-13907-12	13 - 23	6CB-15187-00	3 - 5	68V-24379-10	13 - 11
6CB-11193-00	5 - 31	6JD-11656-00	4 - 14	6AW-13119-00	34 - 11	6CB-13907-22	13 - 23	6CB-15311-01	34 - 1	6GR-24410-01	13 - 27
	52 - 3	6JD-11656-10	4 - 14	6AW-13132-00	13 - 32	63P-13915-00	1 - 11	6BB-15316-01	33 - 29	6CB-24452-10	13 - 18
6CB-11194-00	5 - 35	6JD-11656-20	4 - 14	6CB-13161-11	12 - 1		13 - 24	6CB-15319-00	3 - 43	4SV-24453-00	13 - 38
	52 - 4	6KW-11998-00	5 - 42	6CB-13171-11	12 - 5	6CB-13971-01	14 - 10	6CB-15362-00	34 - 18	69J-24453-00	13 - 38
67F-11301-01	5 - 19	6KW-11999-00	5 - 43	6CB-13300-00	34 - 9	6CB-13972-00	14 - 12	6G8-15363-00	3 - 41	6CB-24460-00	13 - 4
6CB-1131B-00	3 - 12	6CB-12111-00	8 - 1	6CB-13329-00	34 - 10	6CB-13974-01	14 - 11	6CB-15373-01	9 - 8	6CB-24460-10	13 - 4
	52 - 19	6CB-12113-00	8 - 4	6CB-13411-00	34 - 6	6AW-1410B-00	12 - 3	6CB-15377-00	34 - 19	6CB-24461-00	14 - 1
6CE-1131C-00-9S	3 - 9	51Y-12119-00	8 - 7	6AW-13415-00	34 - 7		12 - 7	6CE-15411-00-9S	3 - 14	6P3-24469-00	15 - 9
68T-11325-00	1 - 4	6DA-12121-00	8 - 2		53 - 3	6CB-14146-00	13 - 10	6CE-15421-10-9S	3 - 15	6CB-24482-00	13 - 20
	3 - 32	6KA-12171-00	8 - 9	6CE-13437-61	17 - 18	6P2-14149-00	14 - 2	6CB-15451-01	3 - 17	6CB-24491-00	13 - 30
63P-11325-01	1 - 1	6KA-12172-00	8 - 13	N26-13440-03	1 - 6	6CB-14180-14	13 - 1		52 - 7	6CB-24492-00	13 - 28
	3 - 10	6KA-12181-00	8 - 11		3 - 36	6CB-14180-24	13 - 1	6CB-15481-00	3 - 6	6CB-24501-01	1 - 9
	3 - 19	6KA-12182-00	8 - 15	6CE-13446-10-9S	3 - 38	6CB-14181-01	13 - 15	6CB-15512-00	8 - 29		13 - 3
67F-11325-01	1 - 7	6CE-12411-00	1 - 2	6CB-13473-00	34 - 17	6CB-14182-02	13 - 2	6CB-15544-00	6 - 4	6P3-24519-00	15 - 8
	5 - 20		3 - 21		52 - 15	6CB-14182-20	13 - 2	6KA-2134V-00	5 - 40	6P3-24560-23	15 - 6
63P-11325-11	1 - 16	67F-12412-00	3 - 22	6CB-13477-00	3 - 39	6P2-14191-00	13 - 16	6KA-2134X-00	9 - 16	6P3-24562-21	15 - 7
	33 - 2	6CE-12413-A0-9S	3 - 24		52 - 16	68V-14216-00	13 - 12	6KF-2153A-00	2 - 28	6P3-24563-02	1 - 14
67F-11328-01	5 - 21	6CE-12413-B0-9S	3 - 23	6CB-13490-00	34 - 16	6CB-14216-00	13 - 6	6KF-2153A-10	2 - 28		15 - 11
6AW-1132N-01	1 - 5	6CB-12422-10-9S	3 - 25	6CB-13532-10	10 - 2	6CB-14239-00	13 - 17	6E5-21744-00	10 - 24	6P3-24564-00	1 - 13
	3 - 34	6CB-12427-11	3 - 26	6CB-13533-00	10 - 1	6P2-14386-00	13 - 37	6YM-22480-00	47 - 6		15 - 10
6AW-1132P-00	1 - 3		52 - 8	6CB-13545-00	10 - 18	6AW-1441J-01	9 - 11	6CB-2416A-00	10 - 5	6CB-24566-00	15 - 12
	3 - 30	6CB-1242F-00	6 - 2	6CB-13546-01	10 - 22	6CB-14429-01	13 - 19	69J-24170-00	9 - 14	6CB-24592-00	13 - 29
6KA-11351-00	3 - 29		52 - 5	6CB-13547-00	10 - 23	6CE-14435-00	21 - 28	6FP-2419E-01	9 - 15	6CB-24596-01	15 - 19
	52 - 9	6CB-1243E-00	7 - 15	6CB-13548-00	10 - 25	6CB-14440-01	9 - 9	6CB-24217-00	13 - 7	69J-28100-03	15 - 21
6CB-11355-00	34 - 13	6CE-1244G-00	7 - 12	6CB-13556-00	11 - 3	6CB-1447B-00	13 - 33	6CB-24217-10	13 - 7	67F-2812A-00	20 - 31
	52 - 13	6CE-1244H-00	7 - 14		52 - 12	6CB-14546-00	13 - 26	60E-24300-01	14 - 9	6CB-41132-01	33 - 13
6CB-1135A-00	6 - 6	6CE-12481-10	18 - 24	6CB-13577-00	12 - 4	6CB-14564-00	13 - 9	6Y2-24307-51	16 - 1	6CB-41134-00	33 - 14
6CB-11410-00	4 - 1	6CE-12482-10	10 - 8		12 - 8	63P-14567-00	13 - 36	6CB-24313-10	15 - 17		53 - 6
6CB-11416-00	4 - 5	6CE-12483-00	18 - 18	68V-13577-01	14 - 4	68V-14592-10	13 - 39	6KA-24314-10	15 - 2	6CB-41135-00	33 - 17
6CB-11416-10	4 - 5	6KA-12483-00	10 - 26	6KA-13582-00	25 - 11	6KA-14711-00	33 - 20	6CB-24315-00	25 - 8		53 - 8
6CB-11416-20	4 - 5	6CB-12484-00	10 - 10	6KA-13587-00	25 - 14	6CB-14750-A0	33 - 10	6CB-24317-00	14 - 6	6CE-41136-00	33 - 19
6CB-11416-30	4 - 5	6CE-12485-00	18 - 26	6CB-13593-00	13 - 22	6CB-14755-01	33 - 12	6CB-24323-00	14 - 7		53 - 9
6CB-11416-40	4 - 5	6CE-1248A-00	18 - 16	69J-13631-00	34 - 12		53 - 5	6CB-24324-00	14 - 5	6CE-41137-01	33 - 1
6CB-11417-00	4 - 6	6AW-12572-00	25 - 15	6CE-13641-00	9 - 5	6KA-1475A-00	10 - 27	6E5-24351-51	15 - 3	6CB-41138-00	33 - 16
6CB-11417-10	4 - 6	6KA-12576-00	7 - 3	6CB-13645-00	9 - 6	6KA-1475F-00	10 - 28		16 - 3		53 - 7
6CB-11417-20	4 - 6	6CB-12577-00	7 - 8	6CB-13646-00	9 - 7	6CB-1475G-10	10 - 31	6AW-24360-02	16 - 6	6CB-42134-01	2 - 24
6CB-11417-30	4 - 6	6R3-12581-00	25 - 16	6CB-13711-00	11 - 2	6CB-1475H-00	13 - 13	6Y2-24360-60	16 - 5	6AW-42169-00	25 - 10
6CB-11417-40	4 - 6	6AW-12582-00	25 - 17	63P-13716-00	13 - 21	6CB-1475J-00	13 - 14	6G8-24376-00	10 - 29	6CE-42195-10	27 - 8
6CB-11426-03	4 - 7	6R3-12583-00	25 - 18	6CB-13751-11	11 - 1	6CE-14872-00	18 - 25	6CE-24376-01	18 - 27	6BG-42384-00	25 - 2

NUMERICAL INDEX
INDICE NUMERICO

PART NO. CODIGO N°	REF. NO.	PART NO. CODIGO N°	REF. NO.	PART NO. CODIGO N°	REF. NO.	PART NO. CODIGO N°	REF. NO.	PART NO. CODIGO N°	REF. NO.	PART NO. CODIGO N°	REF. NO.
6DA-42384-00	24 - 26	68F-42753-00	24 - 3	61A-43811-00	31 - 9	69J-43871-00	31 - 61	6CE-44315-00	53 - 38	6CE-45123-00	53 - 11
6CE-42510-00-8D	30 - 1	6CB-42756-00	24 - 31	63P-43812-20	31 - 76	6H1-43872-00	31 - 7	6AW-44322-00	35 - 18	6CE-45127-00	33 - 23
6CE-42510-00-CE	30 - 1	69M-42758-01	18 - 5	61A-43813-02	31 - 18	61A-43874-00	31 - 79		37 - 18		53 - 10
6KA-42541-00	25 - 20		20 - 10	6H1-43814-11	31 - 17	6H1-43875-00	31 - 29		53 - 32	6BB-45152-01	33 - 30
6CB-42545-00	2 - 5	6CB-42761-00	24 - 5	69J-43816-00	31 - 62	61A-43875-10	31 - 82	6CE-44323-01	35 - 25	61A-45155-01	33 - 35
6KF-42610-00-8D	2 - 1	6KA-42766-00	24 - 29	69J-43817-00	31 - 67	61A-43876-01	31 - 26		37 - 25	6KA-45181-00	33 - 18
6KF-42610-10-CE	2 - 1	6KA-42769-00	26 - 15	61A-43818-00	31 - 25	6KA-43879-00	32 - 8		53 - 37	6CE-45211-10-8D	36 - 4
6KA-42613-00-8D	2 - 3	6KF-42770-00-8D	26 - 2	69J-4381C-00	31 - 30	6KA-4387G-00	32 - 14	6CE-44352-00	35 - 23		38 - 4
6KA-42613-00-CE	2 - 3	6KA-42770-00-CE	26 - 2		31 - 35	6KA-43880-00	32 - 1		37 - 23	6CE-45211-10-CE	36 - 4
6KA-42615-00	24 - 7	6CE-42774-A0	26 - 9	69J-4381J-00	31 - 63	6KA-43881-01	32 - 9		53 - 35		38 - 4
6BG-42617-00	21 - 9	6EE-42794-40	24 - 33	69J-43820-01	31 - 78	6KA-43882-00	32 - 12	6CE-44361-00	36 - 3	6KA-45214-00	36 - 19
6CB-42617-00	21 - 10	6EE-42794-50	24 - 34	61A-43821-02	31 - 77	6H1-43883-00	31 - 43		38 - 3		38 - 19
6KA-4261A-00-8D	2 - 2	6EE-42794-70	24 - 33	6KA-43828-00	31 - 70	6KF-43885-00	25 - 6	6CE-44362-00	36 - 9	6KA-45215-00	36 - 20
6KA-4261A-00-CE	2 - 2	6KA-42815-00-8D	24 - 9	6H1-43829-00	31 - 73	69J-43888-00	31 - 71		38 - 9		38 - 20
6KA-42625-00-8D	2 - 6	6KA-42815-00-CE	24 - 9	6KA-4382A-00	29 - 8	69J-43888E-01	31 - 23	6AW-44363-00	36 - 12	6CE-45224-00	36 - 22
6KA-42625-00-CE	2 - 6	6KA-42816-00-8D	24 - 10	69J-4382E-00	31 - 11	69J-4388F-00	31 - 68		38 - 12		38 - 22
6CB-42628-00	2 - 21	6KA-42816-00-CE	24 - 10	69J-43830-01	31 - 33	6KA-4388F-00	32 - 11	6AW-44365-01	35 - 21	6CE-45225-00	36 - 23
6CB-42629-00	21 - 11	6KA-42817-00-8D	24 - 11	69J-43831-00	31 - 65	69J-4388H-00	31 - 66		36 - 1		38 - 23
60V-42629-01	51 - 10	6KA-42817-00-CE	24 - 11	69J-43833-02	31 - 21	69J-4388J-00	31 - 20		36 - 10	6AW-45244-00	35 - 42
6CB-42643-00	25 - 25	6CB-42818-00	24 - 15	69J-43835-10	31 - 19	6KA-43892-00	32 - 4		37 - 21		37 - 42
6CB-42644-00	25 - 26	6CB-42819-00	24 - 16	6KA-43840-00	31 - 2	6CJ-43893-00	31 - 46		38 - 1	6G5-45251-02	1 - 15
6CB-42647-A0	2 - 12	6KF-42828-00	29 - 22	6CJ-43841-00	31 - 42	69J-43894-00	31 - 41		38 - 10		28 - 2
6KW-42662-00	5 - 44	6KF-42829-00	29 - 20	6CJ-43843-00	31 - 53	69J-43899-01	31 - 31		53 - 22	6KA-45254-00	36 - 26
6AW-42663-01	2 - 18	69J-43111-03-8D	28 - 1	6H1-43844-10	31 - 55	61A-4389H-01	31 - 8	6AW-44366-01	36 - 2		38 - 26
6KF-42678-00	2 - 25	69J-43111-03-CE	28 - 1	63P-43844-20	31 - 50	69J-4389J-00	31 - 32		36 - 5	6KA-45255-00	36 - 27
6KF-4267A-00	2 - 26	69J-43112-03-8D	28 - 9	69J-43845-00	31 - 28		31 - 36		38 - 2		38 - 27
6KF-42682-00	2 - 27	69J-43112-03-CE	28 - 9	69A-4384F-00	31 - 39	6CE-44117-10	27 - 14		38 - 5	6KA-45300-00-8D	35 - 1
6X9-42697-00	41 - 6	6KA-43126-00	29 - 14	69J-4384G-00	31 - 58	6CE-44118-A0	27 - 18		53 - 13	6KB-45300-00-8D	37 - 1
	43 - 7	6R3-43131-00	28 - 12	6H1-4384G-11	31 - 54	6JD-44120-01	27 - 20	6KA-44385-00	45 - 1	6KA-45300-00-CE	35 - 1
6AW-42697-10	2 - 22	61A-43132-01	28 - 7	69J-4384H-00	31 - 10	6CE-44121-10	27 - 16	6P2-44391-00	24 - 28	6KB-45300-00-CE	37 - 1
6KA-42710-00-8D	24 - 1	61A-43133-01	28 - 10	61A-4384H-10	31 - 81	6CE-44122-20	27 - 9	6CE-44511-00	30 - 30	6KA-45301-00-8D	35 - 2
6KA-42710-00-CE	24 - 1	66T-43144-00	24 - 20	6CJ-4384M-00	31 - 38	6CE-44142-20	27 - 7	6CE-44514-00	30 - 20		37 - 2
6CB-42716-01	24 - 8	6G5-43144-00	28 - 19	69J-43851-00	31 - 49	6KA-44150-00	35 - 14	6KA-44521-00	33 - 44	6KA-45301-00-CE	35 - 2
61A-42717-00	33 - 9	6E5-43145-01	39 - 8	69J-43853-00	31 - 45	6KB-44150-00	37 - 14		53 - 14		37 - 2
6DA-42717-01	24 - 25	6G5-43148-00	28 - 24	69J-43854-00	31 - 57	6KA-44190-00	36 - 32	6CE-44526-00	30 - 21	69J-45318-01	33 - 32
6KA-42723-00-8D	26 - 10	61A-43181-01	28 - 21	69J-43855-00	31 - 52		38 - 32	6G5-44526-00	28 - 3	6CE-45321-20	35 - 11
6KA-42723-00-CE	26 - 10	6G5-43185-02	28 - 22	6H1-43856-10	31 - 56	6CE-44194-01	30 - 28	6CE-44532-01	30 - 23		37 - 11
6KA-42723-10-8D	46 - 1	6KF-43311-00-8D	28 - 16	61A-43861-00	31 - 14	6CE-44311-01	35 - 16	6CE-44533-00	30 - 29	6CE-45332-00-CA	35 - 69
6KA-42723-10-CE	46 - 1	6KF-43311-00-CE	28 - 16		31 - 16		37 - 16	6CE-44536-00	30 - 22	6CF-45332-01-CA	37 - 67
6BG-42724-01	25 - 1	6AW-43376-00	29 - 18		31 - 74	6AW-44312-00	35 - 22	6CE-44551-00-CA	30 - 6	6AW-45335-00-CA	35 - 31
6E5-42724-01	33 - 8	6KA-43800-00-8D	31 - 1	63P-43861-20	31 - 6		36 - 11	6AW-44552-00-CA	30 - 18		37 - 31
6KA-42725-01	24 - 2	6KA-43800-00-CE	31 - 1	6KA-43862-00	32 - 13		37 - 22	6KA-44555-00	30 - 9	688-45341-10	35 - 4
676-42726-00	26 - 16	6KA-43801-00	31 - 4	6D8-43863-00	31 - 27		38 - 11	6CE-44574-00	30 - 8		37 - 4
6KA-42727-00	25 - 4	6KA-43804-01	32 - 3		31 - 75	6CB-44312-00	35 - 29	6KA-45111-00-8D	33 - 25	6KA-45344-00	35 - 37
6KF-42740-00-8D	26 - 1	6KA-43805-00	32 - 2	61A-43864-00	31 - 80		37 - 29	6KA-45111-00-CE	33 - 25		37 - 37
6KF-42740-00-CE	26 - 1	6KA-43806-00	32 - 5	60V-4386A-00	31 - 44	6CE-44315-00	35 - 26	6CB-45113-10	33 - 26	6CE-45361-10	35 - 84
6CB-42744-00	25 - 31	6CE-4380P-00	31 - 12	6KA-4386K-00	32 - 6		37 - 26		53 - 12		37 - 80
6H4-42748-01	24 - 27	6KA-43810-00	31 - 3	61A-43871-00	31 - 15		53 - 23	6CE-45123-00	33 - 24	6CE-45373-00	1 - 19

NUMERICAL INDEX
INDICE NUMERICO

PART NO. CODIGO N°	REF. NO.	PART NO. CODIGO N°	REF. NO.	PART NO. CODIGO N°	REF. NO.	PART NO. CODIGO N°	REF. NO.	PART NO. CODIGO N°	REF. NO.	PART NO. CODIGO N°	REF. NO.
6CE-45373-00	36 - 30	6CB-45577-20	37 - 74	6KA-45970-00	36 - 39	6E5-61351-01	39 - 2	6CE-81975-00	18 - 13	6X9-82582-00	44 - 3
	38 - 30	6CB-45577-30	35 - 77	6KB-45970-00	38 - 39	6E5-61355-00	39 - 5	6X6-81980-00	49 - 8	68V-82582-10	21 - 3
6CE-45375-00	35 - 8		37 - 74	6CE-45970-20	36 - 39	F2S-6411H-00	2 - 23	6CE-81980-01	21 - 2		42 - 3
	37 - 8	6CB-45577-40	35 - 77	6CF-45970-20	38 - 39	6CE-68303-00	27 - 27	6EE-81994-40	17 - 19		44 - 2
663-45376-00	35 - 7		37 - 74	6KA-45972-00	36 - 39	6P2-81336-01	20 - 33	6EE-81994-50	17 - 20	6X9-82582-10	44 - 4
	37 - 7	6CB-45577-50	35 - 77	6KB-45972-00	38 - 39	6CE-81337-01	17 - 12	6EE-81994-70	17 - 19	6Y8-82582-11	42 - 5
63P-45378-00	35 - 9		37 - 74	6KA-45974-00	36 - 39	6CE-81410-00	17 - 3	6AH-81996-00	24 - 35		44 - 5
	36 - 7	6CB-45577-60	35 - 77	6KB-45974-00	38 - 39	6CB-81443-00	22 - 6	6KA-82105-00	20 - 38		47 - 4
	37 - 9		37 - 74	6KA-45976-00	36 - 39	6CB-81639-10	20 - 27	6P2-82113-00	20 - 30	6E9-82588-00	21 - 22
	38 - 7	6K1-45578-01	37 - 76	6KB-45976-00	38 - 39	6CE-81800-02	23 - 1	6KA-82147-00	28 - 18	6KA-82588-00	20 - 6
63P-45379-00	33 - 42	6K1-45578-10	37 - 76	6CE-45978-20	36 - 39	6CE-81801-01	23 - 5	6E5-82148-00	28 - 5	6CB-82589-01	21 - 8
6CB-45383-00	35 - 82	6K1-45578-20	37 - 76	6CF-45978-20	38 - 39	6CE-81807-00	23 - 8	6AW-82149-00	30 - 14	6X6-8258A-31	47 - 16
	37 - 78	6K1-45578-30	37 - 76	69J-45987-00	36 - 34	6CB-81809-00	23 - 14	67F-82151-00	20 - 25		48 - 8
6CB-45384-00	35 - 83	6K1-45578-40	37 - 76		38 - 34	6CE-81810-00	23 - 3	6CE-82151-00	20 - 21	6X6-8258A-41	49 - 14
	37 - 79	6K1-45578-50	37 - 76	688-45997-01	36 - 35	67F-81813-00	23 - 6	6G1-82151-01	47 - 15	6KF-82590-01	21 - 1
6KA-45501-00	35 - 44	6K1-45578-60	37 - 76		38 - 35	6CE-81820-00	23 - 7	67F-82151-10	20 - 26	6KA-82594-00	21 - 5
	37 - 44	6AW-45587-00	35 - 35	6CE-45C81-10	36 - 40	6CE-81821-00	23 - 11	67F-82151-40	20 - 23	6X6-8259E-20	49 - 12
6T5-45539-00	35 - 43		37 - 35		38 - 40	6CB-81822-02	22 - 4	67F-82151-50	20 - 24	6CE-8259M-00	22 - 12
	37 - 43	6AW-45587-10	35 - 35	6KA-46153-00	33 - 33	6CB-81823-A0	22 - 8	6CE-82170-11	20 - 20	6X6-82716-00	49 - 13
6KA-45550-00	35 - 48		37 - 35	6KF-46894-00	33 - 39	6CB-81826-00	23 - 22	6CB-82310-02	19 - 1	68F-82846-00	20 - 29
6KB-45550-00	37 - 48	6AW-45587-20	35 - 35	6X9-48119-00	43 - 8	69J-81828-00	23 - 23	6CB-82314-00	19 - 3	6KA-83383-01	9 - 22
6KB-45560-00	37 - 50		37 - 35	6X9-4811C-00	41 - 7	6CE-81830-00	23 - 16	6CB-82316-01	18 - 3	703-83383-A0	48 - 7
676-45567-00	35 - 80	6AW-45587-30	35 - 35	6X9-48127-00	41 - 3	6CB-81832-00	23 - 9	6P2-82380-00	11 - 5		49 - 7
6CB-45567-00	35 - 57		37 - 35		43 - 3	6CB-81836-00	23 - 10	6CB-82388-00	21 - 18	6YM-83512-00	47 - 9
	37 - 55	6AW-45587-40	35 - 35	6X9-48167-00	41 - 8	6CE-81839-00	23 - 19	6X6-82510-02	48 - 3	6Y9-83553-00	47 - 12
676-45567-10	35 - 80		37 - 35		43 - 9	67F-8183R-00	23 - 13	6X6-82510-11	49 - 3	6YM-83553-00	47 - 11
6CB-45567-10	35 - 57	6AW-45587-50	35 - 35	6X9-48168-00	43 - 10	60V-8183T-00	23 - 17	6Y8-82521-31	47 - 17	6Y8-83553-02	47 - 14
	37 - 55		37 - 35	6X9-48176-00	41 - 9	6P2-8183X-00	20 - 18	6Y8-82521-51	47 - 17	6E5-83558-00	33 - 37
676-45567-20	35 - 80	6AW-45587-60	35 - 35		43 - 11	6CE-81840-01	23 - 4	703-82532-00	48 - 4	6YD-8356N-00	47 - 13
6CB-45567-20	35 - 57		37 - 35	6DV-4820A-01	27 - 1	67F-81841-00	23 - 12		49 - 4	6AW-83651-01	21 - 24
	37 - 55	6CB-45611-00	35 - 58	6X9-48211-00	42 - 7	6CE-81842-00	23 - 18	6KF-82553-00	29 - 13	6AW-8366B-10	50 - 2
676-45567-30	35 - 80	6KB-45611-00	37 - 56		44 - 7	6BR-81845-00	18 - 7	6Y8-82553-01	47 - 1		51 - 2
6CB-45567-30	35 - 57	6KA-45631-00	35 - 67	6X9-4821A-00	44 - 8	67F-81846-00	23 - 24	6Y8-82553-41	47 - 1	63P-8366C-00	50 - 3
	37 - 55		37 - 65	6X9-48222-00	43 - 5	6CE-81850-00	23 - 2	682-82556-00	48 - 6		51 - 3
676-45567-40	35 - 80	6E5-45633-01	35 - 68	6X9-4822A-00	41 - 2	6CE-81869-00	23 - 21		49 - 6	60V-8366D-00	51 - 5
6CB-45567-40	35 - 57		37 - 66	6X9-4822B-00	43 - 2	67F-81891-00	23 - 15	6P2-82560-01	21 - 21	6YM-83710-16	47 - 5
	37 - 55	6CB-45634-00	35 - 59	704-48287-00	41 - 11	6CE-81919-21	20 - 35	6GR-82563-00	21 - 26	6KA-83720-00	46 - 3
676-45567-50	35 - 80		37 - 57		43 - 13	6Y8-81920-01	47 - 2	6X6-82570-34	48 - 1	6X6-83720-00	49 - 11
6CB-45567-50	35 - 57	61A-45635-00	35 - 63	6X9-48400-00	41 - 5	6KF-81925-00	20 - 1	6X6-82570-41	49 - 1	6YM-83956-00	47 - 7
	37 - 55		37 - 61		43 - 6	6KA-81929-00	20 - 4	6X6-82570-60	49 - 9	6YD-83957-00	47 - 8
6KA-45571-00	35 - 71	6H1-45668-00	35 - 62	6X9-48A01-02	41 - 1	6C5-81941-01	23 - 20	6X6-82571-00	48 - 2	6KA-84516-00	46 - 4
6CB-45576-00	35 - 72		37 - 60	6X9-48A02-02	43 - 1	6CB-81948-02	20 - 8	6X6-82571-10	49 - 2	6P2-85075-00	19 - 6
6CF-45576-00	37 - 69	6KF-45802-00	35 - 45	6E5-61301-01	40 - 1	6KW-81949-00	22 - 13	6X6-82571-20	49 - 10	6Y8-85371-01	42 - 2
6CB-45577-00	35 - 77		37 - 45	6E5-61303-01	40 - 5	6AW-81950-00	20 - 15	6X6-82575-10	49 - 5		44 - 11
	37 - 74	6KF-45802-10	35 - 45	6E5-61311-11	40 - 3	6CB-81952-00	21 - 30	688-82575-12	48 - 5		47 - 3
6CB-45577-10	35 - 77		37 - 45	6E5-61313-00	40 - 2	6AW-8195A-00	20 - 22	6X9-82580-02	42 - 1	64J-85516-01	18 - 4
	37 - 74	6CB-45824-00	35 - 51	6E5-61315-00	40 - 4	6CE-81960-10	18 - 11	6X9-82580-42	44 - 1		20 - 9
6CB-45577-20	35 - 77		37 - 52	6E5-61350-02	39 - 1	6CE-81972-00-9S	18 - 12	6X9-82582-00	42 - 4	6CB-85516-01	17 - 17

NUMERICAL INDEX
INDICE NUMERICO

PART NO. CODIGO N°	REF. NO.	PART NO. CODIGO N°	REF. NO.	PART NO. CODIGO N°	REF. NO.	PART NO. CODIGO N°	REF. NO.	PART NO. CODIGO N°	REF. NO.	PART NO. CODIGO N°	REF. NO.
6CB-85544-00	20 - 28	K0F-A3751-P0	8 - 8	90105-10M00	38 - 31	90149-05048	35 - 47	90201-12064	27 - 4	90387-06289	15 - 15
6CB-85547-00	9 - 10	K0F-A3751-R0	8 - 8	90105-14005	30 - 25		37 - 47	90201-12426	28 - 31	90387-06M03	25 - 28
689-85547-01	15 - 1	K0F-A3751-S0	8 - 8	90109-06277	5 - 33	90149-11001	5 - 27	90201-13M01	28 - 30	90387-06M43	26 - 7
6CB-85561-00	17 - 5	K0F-A3751-T0	8 - 8		5 - 37	90151-05M05	3 - 33	90201-156J2	24 - 13		26 - 12
6CE-85564-00	27 - 6	K0F-A3753-00	8 - 8	90109-06M80	26 - 8	90151-06M02	3 - 11	90201-15M58	30 - 13	90387-07054	2 - 8
6CB-85580-00	17 - 4	K0F-A3753-10	8 - 8	90109-06M81	51 - 6		3 - 20	90201-16032	30 - 10	90387-08104	27 - 5
6X6-85590-42	42 - 6	K0F-A3753-20	8 - 8	90110-05039	36 - 21		33 - 3	90201-186F1	5 - 8	90387-08M37	24 - 23
	44 - 6	K0F-A3753-30	8 - 8		36 - 25	90159-06053	26 - 5		5 - 18	90387-08M45	2 - 16
6CE-85592-00	17 - 8	K0F-A3753-40	8 - 8		38 - 21		26 - 14	90201-26M59	28 - 14	90387-10094	2 - 14
6P2-85780-01	6 - 11	K0F-A3753-50	8 - 8		38 - 25	90167-06M00	42 - 10	90201-301U7	35 - 39	90387-10M05	28 - 26
6CB-85790-00	21 - 20	K0F-A3753-60	8 - 8	90111-06144	26 - 3		44 - 13		37 - 39	90387-10M61	39 - 3
63P-85886-00	21 - 27	K0F-A3753-70	8 - 8	90111-08078	2 - 13	90170-09M05	40 - 10	90201-32008	35 - 79	90387-11005	5 - 26
6GR-85887-00	29 - 10	6CB-W0001-04	52 - 1	90116-10067	36 - 14	90170-14M06	40 - 6	90201-35008	30 - 12	90387-28013	30 - 24
6P2-85896-00	19 - 5	6KA-W0001-20	53 - 1		38 - 14	90170-30M18	35 - 41	90201-40M00	30 - 2	90401-19001	3 - 37
6KA-8591A-01	18 - 1	6CE-W0078-02	1 - 20	90119-05M04	9 - 23		35 - 41	90201-41008	35 - 54	90413-10001	25 - 13
6KA-8591A-10	18 - 1		53 - 30	90119-06287	33 - 43	90171-18M04	36 - 37	90201-68008	35 - 34	90430-06M03	5 - 23
6C5-86120-00	10 - 3	6KA-W009A-00-9S	5 - 1	90119-06291	25 - 29		38 - 37		37 - 34	90430-08003	1 - 18
6CB-86120-00	6 - 1	6KA-W009C-00-9S	5 - 11	90119-06293	18 - 6	90179-06M28	2 - 4	90202-08M41	27 - 10		35 - 5
6YM-87278-00	47 - 10	6CB-W1165-10	4 - 9		20 - 11		5 - 41	90202-32M19	30 - 11		37 - 5
63P-8A4L0-07	50 - 1	6CB-W4624-00	8 - 27	90119-06299	9 - 2	90179-08003	22 - 2	90202-40M47	30 - 5		53 - 15
63P-8A4L2-07	51 - 1	6CE-W8145-01	17 - 1	90119-06309	9 - 19	90179-16017	35 - 49	90206-15M18	24 - 14	90430-14115	5 - 10
K0F-A3233-00	4 - 15	6EK-W9010-00	17 - 2		15 - 13		37 - 49	90214-30003	35 - 40		50 - 4
K0F-A3741-00	8 - 5	90101-09M70	40 - 9	90119-06MA3	18 - 14	90183-02M03	35 - 65		37 - 40		51 - 4
K0F-A3742-00	8 - 6	90101-12065	28 - 29	90119-07001	5 - 5		37 - 63	90249-06M19	28 - 25	90430-14M09	1 - 17
K0F-A3743-00	8 - 3		28 - 29		5 - 15	90183-061A8	26 - 4	90250-08M07	35 - 66		34 - 5
K0F-A3751-00	8 - 8	90101-12066	28 - 33	90119-07234	5 - 6		26 - 13		37 - 64		53 - 2
K0F-A3751-10	8 - 8		28 - 33		5 - 16	90185-05002	36 - 24	90280-04002	35 - 24	90445-07017	51 - 8
K0F-A3751-20	8 - 8	90101-14004	30 - 15	90119-08020	9 - 3		36 - 28		37 - 24	90445-09068	18 - 29
K0F-A3751-30	8 - 8	90105-06035	6 - 3	90119-08168	27 - 3		38 - 24		53 - 36	90445-09120	10 - 9
K0F-A3751-40	8 - 8		9 - 4	90119-08180	35 - 30		38 - 28	90282-05008	35 - 81	90445-09220	7 - 1
K0F-A3751-50	8 - 8	90105-06037	3 - 28		37 - 30	90185-06M07	5 - 45		37 - 77	90445-096H2	7 - 10
K0F-A3751-60	8 - 8		3 - 45	90119-08182	33 - 4		27 - 12	90340-08002	35 - 6	90445-107A5	18 - 19
K0F-A3751-70	8 - 8		6 - 7	90119-08187	24 - 24	90185-09M01	39 - 6		37 - 6	90445-13M01	16 - 2
K0F-A3751-80	8 - 8	90105-06039	25 - 30	90119-08191	35 - 28		40 - 11	90340-14M06	5 - 9	90445-14021	25 - 9
K0F-A3751-90	8 - 8	90105-06151	3 - 18		37 - 28	90185-14M00	30 - 16		34 - 4	90445-15M03	24 - 19
K0F-A3751-A0	8 - 8		3 - 40		53 - 40		30 - 26	90340-18M09	5 - 7	90446-15003	20 - 19
K0F-A3751-B0	8 - 8		22 - 9	90119-10007	33 - 27	90185-22M11	28 - 15		5 - 17	90447-07013	51 - 9
K0F-A3751-C0	8 - 8	90105-06M07	3 - 13	90119-10008	36 - 18	90201-02M00	35 - 64	90386-08008	27 - 2	90462-06013	18 - 21
K0F-A3751-D0	8 - 8		5 - 22		38 - 18		37 - 62	90386-10001	27 - 25	90462-08104	29 - 23
K0F-A3751-E0	8 - 8	90105-06M08	12 - 9	90119-10009	36 - 17	90201-053R1	2 - 10	90386-10M16	28 - 23	90464-07209	10 - 20
K0F-A3751-F0	8 - 8	90105-08175	3 - 7		38 - 17	90201-06068	27 - 11	90386-11001	27 - 22	90464-08004	11 - 9
K0F-A3751-G0	8 - 8		5 - 28	90119-10024	29 - 7	90201-06M02	33 - 41	90386-15M73	24 - 12		21 - 7
K0F-A3751-H0	8 - 8	90105-08178	6 - 5		30 - 19	90201-06M30	42 - 13	90386-18M14	29 - 17	90464-09013	7 - 5
K0F-A3751-J0	8 - 8	90105-08220	5 - 29		30 - 31		44 - 16		31 - 24		10 - 15
K0F-A3751-K0	8 - 8	90105-08M61	35 - 85		36 - 14	90201-10M01	8 - 32	90386-25M31	28 - 13	90464-09129	21 - 29
K0F-A3751-L0	8 - 8		37 - 81		38 - 14	90201-10M20	39 - 7	90386-39M89	30 - 3	90464-10011	10 - 34
K0F-A3751-M0	8 - 8	90105-08M87	22 - 5	90119-10050	8 - 18	90201-10M76	40 - 8	90387-06285	17 - 14	90464-10M59	7 - 4
K0F-A3751-N0	8 - 8	90105-10M00	36 - 31	90119-10M07	8 - 31	90201-11008	27 - 24	90387-06289	9 - 18	90464-11012	10 - 32

NUMERICAL INDEX
INDICE NUMERICO

PART NO. CODIGO N°	REF. NO.	PART NO. CODIGO N°	REF. NO.	PART NO. CODIGO N°	REF. NO.	PART NO. CODIGO N°	REF. NO.	PART NO. CODIGO N°	REF. NO.	PART NO. CODIGO N°	REF. NO.
90464-11121	21 - 13	90465-11M59	7 - 16	92990-06100	2 - 19	93210-22MF1	37 - 46	93501-04011	37 - 59	95D75-06025	27 - 23
90464-12009	14 - 15	90465-13M11	42 - 9	92990-08600	2 - 15		53 - 26	93501-08001	31 - 47		27 - 28
90464-12010	7 - 6		44 - 10	92990-18200	36 - 36	93210-24M79	3 - 42	93503-16003	31 - 37	95D75-06040	34 - 14
	10 - 13	90465-14M66	7 - 17		38 - 36		52 - 17	93505-32038	31 - 13	95D75-08030	9 - 1
	10 - 33		14 - 14	92995-10600	36 - 15	93210-26658	3 - 8		31 - 34	95D75-08060	11 - 4
90464-12012	14 - 16	90467-08004	18 - 34		38 - 15		34 - 15	93604-07M13	27 - 19	95D95-06010	33 - 36
	14 - 17	90467-090A0	10 - 11	92995-14600	30 - 17		52 - 6	93604-35236	31 - 60	95D95-06012	18 - 8
90464-12183	20 - 13	90467-09M09	18 - 20		30 - 27		52 - 14	93605-10108	8 - 10		21 - 6
	21 - 15	90467-130A5	25 - 22	93101-28019	35 - 32	93210-27370	3 - 44		8 - 12		21 - 23
90464-13227	22 - 10	90467-140A8	25 - 23		37 - 32		52 - 18		8 - 14		24 - 21
90464-13249	9 - 20	90467-140A9	14 - 13		53 - 24	93210-33M49	35 - 12		8 - 16		24 - 30
	9 - 24		25 - 24	93101-30019	35 - 75		37 - 12	93606-12019	3 - 3		24 - 32
	18 - 9	90467-141A2	14 - 3		37 - 72		53 - 17		3 - 4	95D95-06014	5 - 39
	20 - 12	90468-18008	27 - 13		53 - 28	93210-35321	30 - 4		4 - 3		15 - 20
90464-16001	21 - 25		27 - 17	93101-30030	35 - 74	93210-37160	35 - 20		35 - 27		24 - 6
90464-16017	25 - 12	90480-06M19	16 - 4		37 - 71		37 - 20		37 - 27	95D95-06016	6 - 9
90464-18004	22 - 11	90480-10M23	9 - 17		53 - 27		53 - 21		53 - 39		10 - 17
90464-18246	21 - 14		15 - 14	93102-38008	8 - 26		53 - 34	93606-19M23	33 - 22		15 - 16
90464-20181	9 - 21	90480-12314	17 - 16		52 - 11	93210-66001	31 - 69	93608-16M16	33 - 7		20 - 7
	10 - 19		19 - 4	93102-85008	4 - 4	93210-69MG6	35 - 36		33 - 28		21 - 19
	18 - 10	90480-13004	2 - 7		52 - 10		37 - 36		34 - 3		21 - 31
	20 - 14	90480-13163	25 - 7	93104-22M07	35 - 17		53 - 25		35 - 52		22 - 7
	21 - 4	90480-13M24	26 - 6		37 - 17	93210-94003	35 - 19		36 - 6		34 - 21
	21 - 16		26 - 11		53 - 19		37 - 19		36 - 13	95D95-06020	18 - 2
	21 - 17	90480-14029	25 - 27		53 - 31		53 - 20		37 - 53		20 - 5
90464-20258	24 - 4	90480-15M31	17 - 15	93106-10001	35 - 13		53 - 33		38 - 6		21 - 12
90464-23001	10 - 6	90480-16009	2 - 11		37 - 13	93211-02001	35 - 76		38 - 13		33 - 11
90464-26002	7 - 9	90480-19031	25 - 5		53 - 18		37 - 73	93700-06002	28 - 17	95D95-06025	9 - 13
	10 - 14	90480-20006	46 - 2	93106-19001	31 - 5		53 - 29		29 - 1		17 - 13
	18 - 23	90480-22M81	24 - 22	93210-064A5	31 - 51	93306-209U0	35 - 70	94702-00400	1 - 8		18 - 15
90464-99004	9 - 12	90501-10M77	35 - 60	93210-06ME6	29 - 16	93311-83280	35 - 3		5 - 46		19 - 2
90465-08M83	29 - 2		37 - 58	93210-07003	35 - 10		37 - 3	95022-06035	17 - 10	95D95-06030	5 - 32
	29 - 5	90506-16003	28 - 28		36 - 8	93311-85894	35 - 50	95023-06012	18 - 22		5 - 36
90465-11M10	7 - 7	90506-22001	24 - 18		37 - 10		37 - 51	95027-06025	3 - 27		17 - 11
	7 - 11	90560-12M01	39 - 4		38 - 8	93315-43061	35 - 73	95380-05600	41 - 12	95D95-08012	24 - 17
	10 - 7	91318-05025	31 - 59		53 - 16		37 - 70		43 - 14	95D95-08016	20 - 2
	10 - 12	91318-05040	31 - 64	93210-08391	31 - 48	93332-00048	37 - 68	95380-06600	2 - 20	95D95-08025	5 - 24
	15 - 5	91380-05020	36 - 29	93210-09165	27 - 21	93332-000A4	35 - 53		10 - 4	97513-06520	20 - 17
	15 - 18		38 - 29		31 - 72	93332-000A5	35 - 78	95380-10600	36 - 16	97513-08545	22 - 1
	17 - 9	91490-40030	36 - 38		36 - 33	93340-67011	35 - 56		38 - 16	97585-06510	29 - 6
	18 - 31		38 - 38		38 - 33		37 - 54	95380-12600	28 - 32		29 - 21
	18 - 32	91690-30020	28 - 27	93210-11001	19 - 7	93341-440U5	37 - 75	95380-14700	40 - 7	97595-05516	29 - 9
	18 - 33	91690-40010	3 - 16	93210-16275	39 - 9	93399-99962	35 - 33	95780-06300	42 - 12		29 - 12
	25 - 3	91690-60022	29 - 15	93210-17239	31 - 22		37 - 33		44 - 15	97595-05520	17 - 7
	25 - 21	91809-08006	5 - 4	93210-17MF9	29 - 11	93410-10082	27 - 26	95780-08300	2 - 17	97602-04306	32 - 7
	29 - 4		5 - 14	93210-19MJ3	34 - 20	93410-37M04	30 - 7	95780-10300	29 - 19	97602-04308	32 - 10
	33 - 38	92990-05300	41 - 4		53 - 4	93420-50093	33 - 34	95812-06025	34 - 8	97607-05212	42 - 8
	51 - 7		43 - 4	93210-22MF1	35 - 46	93501-04011	35 - 61	95814-08020	20 - 3		44 - 9

NUMERICAL INDEX
INDICE NUMERICO

PART NO. CODIGO N°	REF. NO.	PART NO. CODIGO N°	REF. NO.	PART NO. CODIGO N°	REF. NO.	PART NO. CODIGO N°	REF. NO.	PART NO. CODIGO N°	REF. NO.	PART NO. CODIGO N°	REF. NO.
97780-40112	46 - 5										
97780-50016	2 - 9										
97780-50145	41 - 10										
	43 - 12										
97780-50620	20 - 32										
97780-60520	25 - 19										
97880-06035	42 - 11										
	44 - 14										
97885-06010	28 - 8										
	28 - 11										
97985-04308	22 - 3										
97985-06212	28 - 6										
	29 - 3										
97D95-06010	33 - 40										
97D95-06012	33 - 31										
97E75-06525	27 - 15										
97E75-06620	11 - 6										
97E75-08535	33 - 21										
	34 - 2										
97E75-08560	33 - 15										
97E75-10535	33 - 6										
97E75-10545	33 - 5										
97E75-10570	36 - 18										
	38 - 18										
97E95-06512	28 - 20										
97E95-06516	20 - 34										
	51 - 11										
97E95-06520	19 - 8										
97E95-06525	28 - 4										
97E95-06610	20 - 16										
97E95-08516	20 - 36										
	20 - 37										
97E95-08520	35 - 38										
	37 - 38										
98507-04008	13 - 39										
98507-06016	44 - 12										
98580-05060	41 - 10										
	43 - 12										
98780-06530	3 - 31										
98780-06550	3 - 35										
99001-09600	35 - 15										
	37 - 15										
99002-03600	31 - 40										
99009-47500	35 - 55										
99530-08012	17 - 6										
99530-14016	8 - 30										